



# Kraftfahrt-Bundesamt

DE-24932 Flensburg



## MITTEILUNG

ausgestellt von:

**Kraftfahrt-Bundesamt**

### über die Erweiterung der Bestätigung

eines Prüfprotokolls gemäß **Anhang 19 Punkt 2.4 und 3.4** der ECE  
Regelung Nr. 13 für **einen Membranbremszylinder / Federspeicher-  
Bremszylinder**

## COMMUNICATION

issued by:

**Kraftfahrt-Bundesamt**

### on the extension of the confirmation

of a Test Report regarding **Annex 19 item 2.4 and 3.4** of ECE  
Regulation No. 13 for a **diaphragm brake chamber / spring brake  
chamber**

Nummer der Bestätigung: **190324**  
Confirmation No.:

Erweiterung Nr.: **01**  
Extension No.:

1. Fabrikmarke (Handelsname des Herstellers):  
Make (trade name of manufacturer):  
**SAF**
2. Typ:  
Type:  
**MM S 1630 A 6 0; BC 0092.3**
3. Name und Anschrift des Herstellers:  
Name and address of manufacturer:  
**TSE Brakes, Inc.**  
**Cullmann, AL 35055, USA**
4. Gegebenenfalls Name und Anschrift des Vertreters des Herstellers:  
If applicable, name and address of manufacturer's representative:  
**SAF-Holland GmbH**  
**DE-63856 Bessenbach**



# Kraftfahrt-Bundesamt

DE-24932 Flensburg

2

Nummer der Bestätigung: 190324, Erweiterung 01  
Confirmation No.:

5. Für die Durchführung der Prüfungen zuständiger technischer Dienst:  
Technical service responsible for carrying out the tests:  
**TÜV Nord Mobilität GmbH & Co. KG**  
**Institut für Fahrzeugtechnik und Mobilität**  
**DE-45307 Essen**
  
6. Datum des Prüfprotokolls:  
Date of test report:  
**19.05.2017**
  
7. Nummer des Prüfprotokolls:  
Number of test report:  
**BC 0092.3**
  
8. Gegebenenfalls Bemerkungen:  
Remarks (if any):  
**keine - none**
  
9. Ort: **DE-24932 Flensburg**  
Place:
  
10. Datum: **07.07.2017**  
Date:
  
11. Unterschrift: **Im Auftrag**  
Signature:

*Kleist*

(Kleist)





# Kraftfahrt-Bundesamt

DE-24932 Flensburg

---

## Inhaltsverzeichnis zu den Beschreibungsunterlagen Index to the information package

Zur ECE-Bestätigung Nr.: **190324, Erweiterung 01**  
To ECE confirmation No.:

Ausgabedatum: **28.12.2016**  
Date of issue:

letztes Änderungsdatum: **07.07.2017**  
last date of amendment:

1. Nebenbestimmungen und Rechtsbehelfsbelehrung  
Collateral clauses and instruction on right to appeal
  
2. Beschreibungsbogen Nr.: Datum:  
Information document No.: Date:  
-- --  
letztes Änderungsdatum: --  
last date of amendment:
  
3. Prüfbericht(e) Nr.: Datum:  
Test report(s) No.: Date:  
**BC 0092.2** **02.12.2016**  
**BC 0092.3** **19.05.2017**
  
4. Beschreibung der Änderungen:  
Description of the modifications:  
**siehe Anlage - see enclosure**



# Kraftfahrt-Bundesamt

DE-24932 Flensburg

---

Nummer der Bestätigung: 190324, Erweiterung 01  
Number of the Confirmation:

- Anlage -

## Rechtsbehelfsbelehrung

Gegen diese Bestätigung kann innerhalb eines Monats nach Bekanntgabe Widerspruch erhoben werden. Der Widerspruch ist beim **Kraftfahrt-Bundesamt, Fördestraße 16, DE-24944 Flensburg**, schriftlich oder zur Niederschrift einzulegen.

- Attachment -

## Instruction on right to appeal

This Confirmation can be appealed within one month after notification. The appeal is to be filed in writing or as a transcript at the **Kraftfahrt-Bundesamt, Fördestraße 16, DE-24944 Flensburg**.

SAF-HOLLAND GmbH  
COPY

# Test Report

*/Prüfbericht*

*/Procès-verbal d'Essai*

*/Verbale di Prova*

*/Acta de Ensayo*

*/Relatório de Ensaio*

**No. BC 0092.3**

**for application of Annex 19-Part 1 point 2.4/3.4**

**ECE Regulation No. 13**

*zur Anwendung von Anhang 19-Teil 1 Punkt 2.4/3.4*

*der ECE Regelung Nr. 13*

*en application d'appendice 19-Partie 1 point 2.4/3.4*

*du ECE règlement n° 13*

*in applicazione dell'allegato 19-Parte 1 punto 2.4/3.4*

*della ECE regolazione 13*

*en aplicaci3n de ap3ndice 19-Parte 1 ponto 2.4/3.4*

*la ECE regulaci3n 13*

*para aplica33o do Anexo 19-Parte 1 ponto 2.4/3.4*

*da ECE Regula33o n° 13*

TÜV NORD Mobilität  
GmbH & Co. KG  
IFM – Institut für  
Fahrzeugtechnik  
und Mobilität

Adlerstraße 7  
45307 Essen

Tel.: +49 (0) 201 825-4108  
Fax: +49 (0) 201 825-4185

www.tuev-nord.de  
Corporate seat: Hannover  
Commercial Register section  
HRA 27006

Management:  
Hartmut Abeln  
Thorsten Walingner

- 0. REASON FOR THE EXTENSION:**
- /GRUND DER ERWEITERUNG*  
*/MOTIF DE L'EXTENSION*  
*/MOTIVO PER L'ESTENSIONE*  
*/MOTIVO DE LA EXTENSI3N*  
*/RAZ3O PARA A EXTENS3O*
- I) Change of type designation p. 1.3**  
*Änderung der Typbezeichnung P.1.3*  
*Changement de désignation de type p.1.3*  
*Cambio di denominazione del tipo p.1.3*  
*Cambio de denominaci3n del tipo p.1.3*  
*Alteraç3o a designaç3o do tipo p.1.3*
- II) Update appendix 2**  
*Aktualisierung Anlage 2*  
*Mise en jour appendice 2*  
*Aggiornamento appendice 2*  
*Actualizaci3n ap3ndice 2*  
*Actualizaç3o ap3ndice 2*
- III) Extension of the scope of application p. 5**  
*Erweiterung des Verwendungsbereiches P.5*  
*Extension de domaine d'emploi p.5*  
*Estensione gamma di applicazioni p.5*  
*Extensi3n de gama de aplicaci3nes p.5*  
*Extens3o do gama de aplicaç3o p.5*



Test Report Nr. /Prüfbericht Nr. /Procès-Verbal d'Essai N°  
/Verbale di Prova N°/Acta de Ensayo N° /Relatório de Ensaio N°  
Sheet /Blatt/Feuille/Foglio /Hoja /Folha  
Make /Marke /Marque /Marca/Marca/ Marca  
Type /Typ/Type/Tipo/Tipo/Tipo

: BC 0092.3  
: 2 / 8  
: SAF  
: MM S 1630 A 6 0



#### IV) Update of the regulation

Aktualisierung der Vorschrift  
Mise en jour de l'état de la réglementation  
Aggiornamento di regolazione  
Actualización de las regulaciones  
Atualização do regulamentos

### 1. IDENTIFICATION

*/Kennzeichnung*  
*/Identification*  
*/Identificazione*  
*/Identificación*  
*/Identificação*

#### 1.1 Manufacturer:

*/Hersteller*  
*/Fabricant*  
*/Fabricante*  
*/Fábrica*  
*/Fabricante*

TSE Brakes Inc.  
2310 Industrial Drive S.W.  
Cullman, AL 35 055  
United States of America

#### 1.2 Make:

*/Marke*  
*/Marque*  
*/Marca*  
*/Marca*  
*/Marca*

SAF

#### 1.3 Type:

*/Typ*  
*/Type*  
*/Tipo:*  
*/Tipo*  
*/Tipo*

MM S 1630 A 6 0

#### 1.4 Part number

*/Teilenummer*  
*/Numéro du pièce*  
*/Numero del pezzo*  
*/Número de la pieza*  
*/Numero de peça*

4 454 1...6 .



**The part numbers characterized in this report with “....“ represent versions of the tested type, whose modifications have however no influence on the function and effect regarding the tests carried out.**

*Die in diesem Bericht mit „....“ gekennzeichneten Teilenummern stellen eine Version des getesteten Typs dar, dessen Abwandlungen jedoch keinen Einfluss auf die Funktion und Wirkung hinsichtlich der vorgenommenen Prüfungen haben.*

*Les numéros de pièces marquées dans ce procès-verbal avec «....» représentent une version du type éprouvé dont les modifications n'ont toutefois pas d'influence sur la fonction et l'effet concernant les essais exécutés.*

*I numeri del pezzo caratterizzato in questo verbale di prova con “...” rappresentano una versione del tipo provato le cui modifiche non esercitano tuttavia un'influenza sulla funzione e l'effetto riguardo alle prove.*

*Los números de parte caracterizados en este acta de ensayo con “...” representan versiones del tipo probado, cuyas modificaciones no tienen ninguna influencia en la función y efecto en cuanto a las pruebas realizadas.*

*Os números de parte caracterizados neste relatório com “....” representam versões do tipo testado, cujas modificações não têm nenhuma influência na função e efeito quanto aos testes executados.*

## 2. Operating conditions

*/Betriebsbedingungen*

*/Conditions de fonctionnement*

*/Condizioni di gestione*

*/Condición de servicio*

*/Condições de serviço*

### 2.1 Maximum operating pressure:

10 [10<sup>2</sup>kPa]

*/Maximaler Betriebsdruck*

*/Pression de service maximale*

*/Pressione d'esercizio massima*

*/Presión de explotación máxima*

*/Pressão operacional máxima*

## 3. Performance characteristics of the service part diaphragm brake chamber declared by the manufacturer

*/Leistungsdaten des Betriebsbremszylinders Herstellerangabe*

*/Les caractéristiques d'exécution du cylindre de frein a diaphragme déclarer par le fabricant*

*/Le caratteristiche di prestazioni di cilindro a diaframma dichiarato dal fabbricante.*

*/Las características de explotación de cámara de freno de diafragma según indicación del fabricante.*

*/As características de realização da câmara de freio de diafragma declaradas pelo fabricante*

### 3.1 Maximum stroke ( $s_{max}$ ) at 6.5 \* 10<sup>2</sup>kPa:

*/Maximaler Hub ( $s_{max}$ ) bei 6.5 \* 10<sup>2</sup>kPa*

*/Course maximale ( $s_{max}$ ) à 6.5 \* 10<sup>2</sup>kPa*

*/Corsa massima ( $s_{max}$ ) a 6.5 \* 10<sup>2</sup>kPa*

*/Carrera máxima ( $s_{max}$ ) a 6.5 \* 10<sup>2</sup>kPa*

*/Curso máxima ( $s_{max}$ ) em 6.5 \* 10<sup>2</sup>kPa*

64 [mm]



### 3.2 Average thrust ( $Th_A$ ) = f (p):

*/Durchschnittliche Kraft ( $Th_A$ ) = f (p)*

*/Moyenne effort ( $Th_A$ ) = f (p)*

*/Spinta media ( $Th_A$ ) = f (p)*

*/Empuje medio ( $Th_A$ ) = f (p)*

*/Esforço médio ( $Th_A$ ) = f (p)*

$$1071 \text{ [N/10}^2\text{kPa]} * p^2 - 372 \text{ [N]}$$

### 3.3 Effective stroke ( $s_p$ ) = f (p):

*/Nutzbarer Hub ( $s_p$ ) = f (p)*

*/Course utile ( $s_p$ ) = f (p)*

*/Corsa utile ( $s_p$ ) = f (p)*

*/Recorrido efectivo ( $s_p$ ) = f (p)*

*/Curso efectivo ( $s_p$ ) = f (p)*

$$0,40 \text{ [mm/10}^2\text{kPa]} * p^2 + 55 \text{ [mm]}$$

#### 3.3.1 Pressure range over which the above affected stroke is valid:

*/Druckbereich für den der oben ermittelte Hub gültig ist*

*/Domaine de pression où la course ci-dessus affectées est valide*

*/Gamma di pressione che il colpo sopra e influenzato è valido.*

*/Gama di presión por si la carrera arrabia mencionado es válida.*

*/Gama de pressão onde o curso mencinado supradito é valido.*

$$2 - 10 \text{ [10}^2\text{kPa]}$$

#### 3.4 Pressure required to produce a push rod stroke of 15 mm ( $p_{15}$ ) Declared by the manufacturer

*/Benötigter Ansprechdruck, um einen Hub der Kolbenstange von 15 mm ( $p_{15}$ ) zu erzeugen. Herstellerangabe*

*/Pression pour appliquer une course de piston de 15 mm ( $p_{15}$ ). Déclarer par le fabricant*

*/Pressione per applicare una corsa del stantuffo di 15 mm ( $p_{15}$ ) Dichiarato del fabbricante*

*/Présion por aplicar una carrera de vástago de 15 mm ( $p_{15}$ ). Indicación del fábricante*

*/Pressão necessitada para produzir um curso de pistão de 15 mm ( $p_{15}$ ) Declarado pelo fabricante*

$$0,30 \text{ [10}^2\text{kPa]}$$

#### 4. Performance characteristics of the spring brake chamber declared by the manufacturer

*/Betriebsdaten des Federspeicher – Bremszylinders nach Herstellerangabe*

*/Les caractéristiques d'exécution du cylindre de frein à ressort déclarer par le fabricant*

<sup>2)</sup> p → [10<sup>2</sup>kPa]





Test Report Nr. /Prüfbericht Nr. /Procès-Verbal d'Essai N° /Verbale di Prova N°/Acta de Ensayo N° /Relatório de Ensaio N°	: BC 0092.3
Sheet /Blatt/Feuille/Foglio/Hoja/Folha	: 5 / 8
Make /Marke /Marque /Marca/Marca/ Marca	: SAF
Type /Typ/Type/Tipo/Tipo/Tipo	: MM S 1630 A 6 0



***/Le caratteristiche di prestazioni di cilindro a molla  
dichiarato dal fabbricante***

***/Las características de explotación de cámara de estacionamiento de diafragma  
según indicación del fabricante***

***/As características de realização da câmara do estacionamento de diafragma  
declaradas pelo fabricante***

#### **4.1 Operating conditions<sup>3)</sup>**

*/Betriebsbedingungen*  
*/Conditions de fonctionnement*  
*/Condizioni di gestione*  
*/Condición de servicio*  
*/Condições de serviço*

#### **4.2 Maximum working pressure:**

8,5 [10<sup>2</sup> kPa]

*/Maximaler Betriebsdruck*  
*/Pression de service maximale*  
*/Pressione di esercizio massima*  
*/Presión de explotación máxima*  
*/Pressão operacional máxima*

#### **4.3 Maximum stroke (s<sub>max</sub>) :**

*/Maximaler Hub (s<sub>max</sub>)*  
*/Course maximale (s<sub>max</sub>)*  
*/Corsa massima (s<sub>max</sub>)*  
*/Recorrido máxima (s<sub>max</sub>)*  
*/Curso máxima (s<sub>max</sub>)*

64 [mm]

#### **4.4 Average thrust (Th<sub>S</sub>) = f (s):**

*/Durchschnittliche Kraft (Th<sub>S</sub>) = f (s)*  
*/Moyenne effort (Th<sub>S</sub>) = f (s)*  
*/Spinta media (Th<sub>S</sub>) = f (s)*  
*/Empuje medio (Th<sub>S</sub>) = f (s)*  
*/Esforço médio (Th<sub>S</sub>) = f (s)*

9615 [N] – 67 [N/mm] \* s<sup>4)</sup>

#### **4.5 Release pressure (at 10 mm stroke):**

5,2 [10<sup>2</sup>kPa]

*/Lösedruck (bei 10 mm Hub)*  
*/Pression de desserrage (à course de 10 mm)*  
*/Pressione di rilascio (a corsa di 10 mm)*  
*/Presión de descarga (a recorrido de 10 mm)*  
*/Pressão de descarregar (em curso de 10 mm)*

<sup>3)</sup> Zero datum position at 7,0\*10<sup>2</sup> kPa / Nullpunkt bei 7,0\*10<sup>2</sup> kPa / Point zéro à 7,0\*10<sup>2</sup> kPa  
/ Punto zero 7,0\*10<sup>2</sup> kPa / Punto cero a 7,0\*10<sup>2</sup> kPa / Ponto zero em 7,0\*10<sup>2</sup> kPa

<sup>4)</sup> s→ [mm]



Test Report Nr. /Prüfbericht Nr. /Procès-Verbal d'Essai N° : BC 0092.3  
/Verbale di Prova N°/Acta de Ensayo N° /Relatório de Ensaio N°  
Sheet /Blatt/Feuille/Foglio/Hoja/Folha : 6 / 8  
Make /Marke /Marque /Marca/Marca/ Marca : SAF  
Type /Typ/Type/Tipo/Tipo/Tipo : MM S 1630 A 6 0



**5. Scope of application**

*/Verwendungsbereich*  
*/Domaine d'emploi*  
*/Gamma di applicazioni*  
*/Gama de aplicaciones*  
*/Gama de aplicação*

**The brake chamber may be used on trailers of categories 0<sub>3</sub>, 0<sub>4</sub>, S and R**

*/Der Bremszylinder ist für die Fahrzeuge der Kategorien 0<sub>3</sub>, 0<sub>4</sub>, S und R geeignet*  
*/Le cylindre de frein peut utiliser pour véhicules des catégories 0<sub>3</sub>, 0<sub>4</sub>, S et R*  
*/Il cilindro del freno può utilizzare per veicoli delle categorie 0<sub>3</sub>, 0<sub>4</sub>, S e R*  
*/El cámara de freno es apropiado para los vehículos de las categorías 0<sub>3</sub>, 0<sub>4</sub>, S y R*  
*/La câmara de freio é apropriado para veículos de categorias 0<sub>3</sub>, 0<sub>4</sub>, S e R*

**6. NAME OF TECHNICAL SERVICE CONDUCTING THE TEST:**

*/NAME DES TECHNISCHEN DIENSTES, DER DIE PRÜFUNG DURCHGEFÜHRT HAT*  
*/NOM DU SERVICE TECHNIQUE EFFECTUANT L'ESSAI*  
*/NOME DI SERVIZIO TECNICO INCARICATO DELLA PROVA*  
*/NOMBRE DEL SERVICIO TÉCNICO QUE HA EFECTUADO EL ENSAYO*  
*/NOME DO SERVIÇO TÉCNICO QUE REALIZOU O ENSAIO*

TÜV NORD Mobilität GmbH & Co KG  
Institut für Fahrzeugtechnik und Mobilität- IFM  
Adlerstr. 7  
D-45307 Essen

**7. Date of test:**

*/Prüfdatum*  
*/Date de l'essai* 20.12.2007  
*/Data della prova*  
*/Fecha del ensayo*  
*/Data do Ensaio*

**8. This test has been carried out and the results reported in accordance with Annex 19-Part 1 paragraph 4 to ECE Regulation No. 13, supplement 14 to the 11 series of amendments.**

*/Dieser Test, sowie die Ergebnisse wurden in Übereinstimmung mit Anhang 1- Teil 1 Punkt 4 der ECE Regelung Nr. 13 Ergänzung 14 zur 11 Änderungsserie durchgeführt und protokolliert.*

*/Cet essai a été effectué et les résultats ont été rapportés selon paragraphe 4 l'annexe 19-Partie 1 de règlement ECE N°13 complément 14 aux 11 séries d'amendements.*

*/Questa prova è stata eseguita ed i risultati sono stati annotati in conformità con paragrafo 4 allegato 19-Parte 1 della regolazione n° 13 dell'ECE, supplemento 14 alle 11 serie delle correzioni.*



Test Report Nr. /Prüfbericht Nr. /Procès-Verbal d'Essai N° : BC 0092.3  
/Verbale di Prova N°/Acta de Ensayo N° /Relatório de Ensaio N°  
Sheet /Blatt/Feuille/Foglio/Hoja /Folha : 7 / 8  
Make /Marke /Marque /Marca/Marca/ Marca : SAF  
Type /Typ/Type/Tipo/Tipo/Tipo : MM S 1630 A 6 0



*/ Este ensayo sido efectuado y sus resultados consignados con arreglo a lo prescrito por el parágrafo 4 apéndice 19-Parte 1 de la regulación n°13 de la ECE, suplemento 14 a la 11 serie de enmiendas.*

*/Este ensaio foi efectuado e os seus resultados sao emconforme o parágrafo 4 do Anexo 19-Parte 1 à regulção ECE N. 13, o suplemento 14 às 11 séries de emendas.*

Essen, 19.05.2017

B6-8114441442

  
Dipl.-Ing. Böker



TÜV NORD Mobilität GmbH & Co. KG  
IFM - Institut für Fahrzeugtechnik und Mobilität  
Adlerstr. 7, 45307 Essen

Akkreditiert nach / *accredited* DIN EN ISO/IEC 17025: D-PL-11109-01-00  
Benannt als Technischer Dienst / *Designated as Technical Service*  
vom Kraftfahrt-Bundesamt / *by Kraftfahrt-Bundesamt: KBA-P 00004-96*

## 9. Approval Authority

*/Typgenehmigungsbehörde*

*/Autorité Compétente en matière de réception*

*/Autorità che rilascia l'omologazione*

*/Organismo competente en materia de homologación*

*/Autoridade de recepção*

- = > See separate sheet issued by the German Approval Authority (KBA)  
*Siehe separates Beiblatt der deutschen Genehmigungsbehörde (KBA)*  
*Voir fiche séparée emis par l'Autorité Compétente allemand (KBA)*  
*Vedi foglio rilasciato dal autorità di omologazione tedesco (KBA)*  
*Ve la hoja separada emitida por la aprobación de la autoridad alemana ( KBA)*  
*Ver folha separada emitido pela aprovação da autoridade alemão( KBA)*

Test Report Nr. /Prüfbericht Nr. /Procès-Verbal d'Essai N° : BC 0092.3  
/Verbale di Prova N°/Acta de Ensayo N° /Relatório de Ensaio N°  
Sheet /Blatt/Feuille/Foglio/Hoja/Folha : 8 / 8  
Make /Marke /Marque /Marca/Marca/ Marca : SAF  
Type /Typ/Type/Tipo/Tipo/Tipo : MM S 1630 A 6 0



## 10. Test Documents

*/Prüfunterlagen*  
*/Documents d'essai*  
*/Documenti della Prova*  
*/Documentos de ensayo*  
*/Documentos de ensaio*

**Appendix 1:** Test Results (10 sheets )

*/Anlage 1 Prüfergebnisse (10 Blätter )*

*/Appendice 1 Résultats d'essai (10 feuilles )*

*/Appendice 1 Risultati della Prova (10 fogli )*

*/Apendice 1 Resultados de ensayo (10 hojas)*

*/Apêndice 1 Resultados de ensaio (10 folhas)*

**Appendix 2:** Overall Dimensions (1 sheets )

*/Anlage 2 Hauptabmessungen (1 Blätter )*

*/Appendice 2 Dimensions principale (1 feuilles )*

*/Appendice 2 Dimensioni principali (1 fogli )*

*/Apendice 2 Dimensiões principal (1 hojas)*

*/Apêndice 2 Dimensões principais (1 folhas)*



Test Report Nr. /Prüfbericht Nr. /Procès-Verbal d'Essai N° : BC 0092.3  
 /Verbale di Prova N°/Acta de Ensayo N° /Relatório de Ensaio N°  
 Appendix /Anlage /Appendice / Appendice/Appendice/Appendice  
 Sheet /Blatt/Feuille/Foglio /Hoja/Folha : 1 / 10  
 Make /Marke /Marque /Marca/Marca/ Marca : SAF  
 Type /Typ/Type/Tipo/Tipo/Tipo : MM S 1630 A 6 0



## 1 Test Results for the diaphragm brake chamber

*/Prüfungsergebnisse für die Membranbremszylinder*  
*/Résultats d'essai pour les cylindres à diafragme*  
*/Risultati della Prova per i cilindri a diaframma*  
*/Resultados des ensayos para las cámaras de freno de diafragma*  
*/Resultados dos ensaios para as câmaras de freio à diafragma*

### 1.1 Sample 1

*/Prüfmuster*  
*/Échantillon*  
*/Campione*  
*/Espécimen*  
*/Amostra*

**p<sub>15</sub> : 0,25 [10<sup>2</sup>kPa]**

Pressure	Average Thrust	Effective Stroke
<i>Druck</i>	<i>Durchschnittliche Kraftabgabe</i>	<i>Effektiver Hub</i>
<i>Pressure</i>	<i>Moyen force</i>	<i>Course effective</i>
<i>Pressione</i>	<i>Forza media</i>	<i>Corsa effettivo</i>
<i>Presión</i>	<i>Empuje medio</i>	<i>Recorrido efectivo</i>
<i>Pressão</i>	<i>Esforço médio</i>	<i>Curso efectivo</i>
<b>p</b>	<b>Th<sub>A</sub></b>	<b>s<sub>p</sub></b>
<b>[10<sup>2</sup>kPa]</b>	<b>[N]</b>	<b>[mm]</b>
<b>1,0</b>	762	50,54
<b>2,0</b>	1.799	58,71
<b>3,0</b>	2.887	60,28
<b>4,0</b>	3.946	61,25
<b>5,0</b>	5.009	62,29
<b>6,0</b>	6.091	62,81
<b>6,5</b>	6.608	63,19
<b>7,0</b>	7.139	63,64
<b>8,0</b>	8.210	64,10
<b>9,0</b>	9.273	64,37
<b>10,0</b>	10.333	64,40



Test Report Nr. /Prüfbericht Nr. /Procès-Verbal d'Essai N° : BC 0092.3  
 /Verbale di Prova N°/Acta de Ensayo N° /Relatório de Ensaio N°  
 Appendix /Anlage /Appendice / Appendice/Appendice/Appendice : 1  
 Sheet /Blatt/Feuille/Foglio /Hoja/Folha : 2 / 10  
 Make /Marke /Marque /Marca/Marca/ Marca : SAF  
 Type /Typ/Type/Tipo/Tipo/Tipo : MM S 1630 A 6 0



## 1.2 Sample 2

/Prüfmuster  
 /Échantillon  
 /Campione  
 /Especimen  
 /Amostra

**p<sub>15</sub> : 0,30 [10<sup>2</sup>kPa]**

Pressure	Average Thrust	Effective Stroke
<i>Druck</i>	<i>Durchschnittliche Kraftabgabe</i>	<i>Effektiver Hub</i>
<i>Pressure</i>	<i>Moyen force</i>	<i>Course effective</i>
<i>Pressione</i>	<i>Forza media</i>	<i>Corsa effettivo</i>
<i>Presión</i>	<i>Empuje medio</i>	<i>Recorrido efectivo</i>
<i>Pressão</i>	<i>Esforço médio</i>	<i>Curso efectivo</i>
<b>p</b>	<b>Th<sub>A</sub></b>	<b>s<sub>p</sub></b>
<b>[10<sup>2</sup>kPa]</b>	<b>[N]</b>	<b>[mm]</b>
<b>1,0</b>	740	49,99
<b>2,0</b>	1.801	57,75
<b>3,0</b>	2.846	58,95
<b>4,0</b>	3.927	59,79
<b>5,0</b>	4.996	60,61
<b>6,0</b>	6.058	61,27
<b>6,5</b>	6.608	61,56
<b>7,0</b>	7.128	61,62
<b>8,0</b>	8.166	61,81
<b>9,0</b>	9.298	62,00
<b>10,0</b>	10.294	62,10



Test Report Nr. /Prüfbericht Nr. /Procès-Verbal d'Essai N° : BC 0092.3  
 /Verbale di Prova N°/Acta de Ensayo N° /Relatório de Ensaio N°  
 Appendix /Anlage /Appendice / Appendice/Appendice/Appendice : 1  
 Sheet /Blatt/Feuille/Foglio /Hoja/Folha : 3 / 10  
 Make /Marke /Marque /Marca/Marca/ Marca : SAF  
 Type /Typ/Type/Tipo/Tipo/Tipo : MM S 1630 A 6 0



### 1.3 Sample 3

*/Prüfmuster*  
*/Échantillon*  
*/Campione*  
*/Especimen*  
*/Amostra*

**p<sub>15</sub> : 0,25 [10<sup>2</sup>kPa]**

Pressure	Average Thrust	Effective Stroke
<i>Druck</i> <i>Pressure</i> <i>Pressione</i> <i>Presión</i> <i>Pressão</i>	<i>Durchschnittliche Kraftabgabe</i> <i>Moyen force</i> <i>Forza media</i> <i>Empuje medio</i> <i>Esforço médio</i>	<i>Effektiver Hub</i> <i>Course effective</i> <i>Corsa effettivo</i> <i>Recorrido efectivo</i> <i>Curso efectivo</i>
<b>p</b>	<b>Th<sub>A</sub></b>	<b>s<sub>p</sub></b>
<b>[10<sup>2</sup>kPa]</b>	<b>[N]</b>	<b>[mm]</b>
<b>1,0</b>	732	54,10
<b>2,0</b>	1.787	58,41
<b>3,0</b>	2.862	59,80
<b>4,0</b>	3.955	60,78
<b>5,0</b>	5.020	61,47
<b>6,0</b>	6.090	62,02
<b>6,5</b>	6.576	62,30
<b>7,0</b>	7.144	62,55
<b>8,0</b>	8.164	62,63
<b>9,0</b>	9.281	62,50
<b>10,0</b>	10.295	62,30



Test Report Nr. /Prüfbericht Nr. /Procès-Verbal d'Essai N° : BC 0092.3  
 /Verbale di Prova N°/Acta de Ensayo N° /Relatório de Ensaio N°  
 Appendix /Anlage /Appendice / Appendice/Appendice/Appendice : 1  
 Sheet /Blatt/Feuille/Foglio /Hoja/Folha : 4 / 10  
 Make /Marke /Marque /Marca/Marca/ Marca : SAF  
 Type /Typ/Type/Tipo/Tipo/Tipo : MM S 1630 A 6 0



#### 1.4 Sample 4

/Prüfmuster  
 /Échantillon  
 /Campione  
 /Especimen  
 /Amostra

**p<sub>15</sub> : 0,25 [10<sup>2</sup>kPa]**

Pressure	Average Thrust	Effective Stroke
<i>Druck</i>	<i>Durchschnittliche Kraftabgabe</i>	<i>Effektiver Hub</i>
<i>Pressure</i>	<i>Moyen force</i>	<i>Course effective</i>
<i>Pressione</i>	<i>Forza media</i>	<i>Corsa effettivo</i>
<i>Presión</i>	<i>Empuje medio</i>	<i>Recorrido efectivo</i>
<i>Pressão</i>	<i>Esforço médio</i>	<i>Curso efectivo</i>
<b>p</b>	<b>Th<sub>A</sub></b>	<b>s<sub>p</sub></b>
<b>[10<sup>2</sup>kPa]</b>	<b>[N]</b>	<b>[mm]</b>
<b>1,0</b>	713	54,17
<b>2,0</b>	1.795	60,74
<b>3,0</b>	2.856	61,84
<b>4,0</b>	3.920	62,80
<b>5,0</b>	5.009	63,37
<b>6,0</b>	6.052	63,95
<b>6,5</b>	6.576	64,31
<b>7,0</b>	7.105	64,71
<b>8,0</b>	8.167	65,16
<b>9,0</b>	9.252	65,42
<b>10,0</b>	10.279	65,44





Test Report Nr. /Prüfbericht Nr. /Procès-Verbal d'Essai N° : BC 0092.3  
 /Verbale di Prova N°/Acta de Ensayo N° /Relatório de Ensaio N°  
 Appendix /Anlage /Appendice / Appendice/Appendice/Appendice  
 Sheet /Blatt/Feuille/Foglio /Hoja/Folha : 6 / 10  
 Make /Marke /Marque /Marca/Marca/ Marca : SAF  
 Type /Typ/Type/Tipo/Tipo/Tipo : MM S 1630 A 6 0



## 1.6 Sample 6

/Prüfmuster  
 /Échantillon  
 /Campione  
 /Especimen  
 /Amostra

$p_{15}$  : 0,25 [10<sup>2</sup>kPa]

Pressure	Average Thrust	Effective Stroke
<i>Druck</i>	<i>Durchschnittliche Kraftabgabe</i>	<i>Effektiver Hub</i>
<i>Pressure</i>	<i>Moyen force</i>	<i>Course effective</i>
<i>Pressione</i>	<i>Forza media</i>	<i>Corsa effettivo</i>
<i>Presión</i>	<i>Empuje medio</i>	<i>Recorrido efectivo</i>
<i>Pressão</i>	<i>Esforço médio</i>	<i>Curso efectivo</i>
<b>p</b>	<b>Th<sub>A</sub></b>	<b>S<sub>p</sub></b>
<b>[10<sup>2</sup>kPa]</b>	<b>[N]</b>	<b>[mm]</b>
<b>1,0</b>	750	54,07
<b>2,0</b>	1.790	60,96
<b>3,0</b>	2.869	62,22
<b>4,0</b>	3.913	63,12
<b>5,0</b>	5.010	63,87
<b>6,0</b>	6.066	64,60
<b>6,5</b>	6.618	64,88
<b>7,0</b>	7.119	65,22
<b>8,0</b>	8.157	65,61
<b>9,0</b>	9.233	65,83
<b>10,0</b>	10.253	65,88



Test Report Nr. /Prüfbericht Nr. /Procès-Verbal d'Essai N° : BC 0092.3  
 /Verbale di Prova N°/Acta de Ensayo N° /Relatório de Ensaio N°  
 Appendix /Anlage /Appendice / Appendice/Appendice/Appendice : 1  
 Sheet /Blatt/Feuille/Foglio /Hoja/Folha : 5 / 10  
 Make /Marke /Marque /Marca/Marca/ Marca : SAF  
 Type /Typ/Type/Tipo/Tipo/Tipo : MM S 1630 A 6 0



### 1.5 Sample 5

*/Prüfmuster*  
*/Échantillon*  
*/Campione*  
*/Especimen*  
*/Amostra*

**p<sub>15</sub> : 0,25 [10<sup>2</sup>kPa]**

Pressure	Average Thrust	Effective Stroke
<i>Druck</i>	<i>Durchschnittliche Kraftabgabe</i>	<i>Effektiver Hub</i>
<i>Pressure</i>	<i>Moyen force</i>	<i>Course effective</i>
<i>Pressione</i>	<i>Forza media</i>	<i>Corsa effettivo</i>
<i>Presión</i>	<i>Empuje medio</i>	<i>Recorrido efectivo</i>
<i>Pressão</i>	<i>Esforço médio</i>	<i>Curso efectivo</i>
<b>p</b>	<b>Th<sub>A</sub></b>	<b>s<sub>p</sub></b>
<b>[10<sup>2</sup>kPa]</b>	<b>[N]</b>	<b>[mm]</b>
<b>1,0</b>	718	52,23
<b>2,0</b>	1.790	58,77
<b>3,0</b>	2.854	60,01
<b>4,0</b>	3.915	60,87
<b>5,0</b>	4.984	61,63
<b>6,0</b>	6.058	62,27
<b>6,5</b>	6.581	62,56
<b>7,0</b>	7.117	62,81
<b>8,0</b>	8.165	63,03
<b>9,0</b>	9.269	62,95
<b>10,0</b>	10.295	62,81



Test Report Nr. /Prüfbericht Nr. /Procès-Verbal d'Essai N° : BC 0092.3  
 /Verbale di Prova N°/Acta de Ensaio N° /Relatório de Ensaio N°  
 Appendix /Anlage /Appendice / Appendice/Appendice/Appendice : 1  
 Sheet /Blatt/Feuille/Foglio /Hoja/Folha : 7 / 10  
 Make /Marke /Marque /Marca/Marca/ Marca : SAF  
 Type /Typ/Type/Tipo/Tipo/Tipo : MM S 1630 A 6 0



## 2 Test Results for the spring brake chamber

*/Prüfungsergebnisse für die Federspeicher -Bremszylinder*  
*/Résultats d'essai pour les cylindres à ressort*  
*/Risultati della Prova per i cilindri a molla*  
*/Resultados des ensayos para las cámaras de freno de diafragma*  
*/Resultados dos ensaios para as câmaras de freio à diafragma*

### 2.1 Sample 1

*/Prüfmuster*  
*/Échantillon*  
*/Campione*  
*/Espécimen*  
*/Amostra*

Stroke /Hub /Corse /Corsa /Recorrido /Curso	Thrust /Kraft /Force /Forza /Empuje /Esforço
s-[mm]	Th <sub>s</sub> [N]
12,5	9.194
22,5	8.475
32,5	7.447
42,5	6.846
52,5	6.515

**Release pressure at 10 mm stroke 5,10 [10<sup>2</sup>kPa]**

*/Lösedruck bei 10 mm Hub*  
*/Pression de desserrage à une course de 10 mm*  
*/Pressione di rilascio a una corsa di 10 mm*  
*/Presión de descarga a recorrido de 10 mm*  
*/Pressão de descarregar em curso de 10 mm*



Test Report Nr. /Prüfbericht Nr. /Procès-Verbal d'Essai N° : BC 0092.3  
 /Verbale di Prova N°/Acta de Ensayo N° /Relatório de Ensaio N°  
 Appendix /Anlage /Appendice / Appendice/Appendice/Appendice  
 : 1  
 Sheet /Blatt/Feuille/Foglio/Hoja/Folha : 8 / 10  
 Make /Marke /Marque /Marca/Marca/ Marca : SAF  
 Type /Typ/Type/Tipo/Tipo/Tipo : MM S 1630 A 6 0



## 2.2 Sample 2

/Prüfmuster  
 /Échantillon  
 /Campione  
 /Especimen  
 /Amostra

Stroke /Hub /Corse /Corsa /Recorrido /Curso	Thrust /Kraft /Force /Forza /Empuje /Esforço
s-[mm]	Th <sub>s</sub> [N]
12,5	8.972
22,5	8.232
32,5	7.365
42,5	6.596
52,5	5.865

**Release pressure at 10 mm stroke** **5,20 [10<sup>2</sup>kPa]**

/Lösedruck bei 10 mm Hub  
 /Pression de desserrage à une course de 10 mm  
 /Pressione di rilascio a una corsa di 10 mm  
 /Presión de descarga a recorrido de 10 mm  
 /Pressão de descarregar em curso de 10 mm

## 2.3 Sample 3

/Prüfmuster  
 /Échantillon  
 /Campione  
 /Especimen  
 /Amostra

Stroke /Hub /Corse /Corsa /Recorrido /Curso	Thrust /Kraft /Force /Forza /Empuje /Esforço
s-[mm]	Th <sub>s</sub> [N]
12,5	9.055
22,5	8.352
32,5	7.353
42,5	6.856
52,5	6.397

**Release pressure at 10 mm stroke** **5,20 [10<sup>2</sup>kPa]**

/Lösedruck bei 10 mm Hub  
 /Pression de desserrage à une course de 10 mm  
 /Pressione di rilascio a una corsa di 10 mm  
 /Presión de descarga a recorrido de 10 mm  
 /Pressão de descarregar em curso de 10 mm



Test Report Nr. /Prüfbericht Nr. /Procès-Verbal d'Essai N° : BC 0092.3  
 /Verbale di Prova N°/Acta de Ensayo N° /Relatório de Ensaio N°  
 Appendix /Anlage /Appendice / Appendice/Appendice/Appendice : 1  
 Sheet /Blatt/Feuille/Foglio/Hoja/Folha : 9 / 10  
 Make /Marke /Marque /Marca/Marca/ Marca : SAF  
 Type /Typ/Type/Tipo/Tipo/Tipo : MM S 1630 A 6 0



## 2.4 Sample 4

/Prüfmuster  
 /Échantillon  
 /Campione  
 /Especimen  
 /Amostra

Stroke /Hub /Corse /Corsa /Recorrido /Curso	Thrust /Kraft /Force /Forza /Empuje /Esforço
s-[mm]	Th <sub>s</sub> [N]
12,5	9.158
22,5	8.442
32,5	7.572
42,5	6.867
52,5	6.434

**Release pressure at 10 mm stroke** **5,10 [10<sup>2</sup>kPa]**

/Lösedruck bei 10 mm Hub  
 /Pression de desserrage à une course de 10 mm  
 /Pressione di rilascio a una corsa di 10 mm  
 /Presión de descarga a recorrido de 10 mm  
 /Pressão de descarregar em curso de 10 mm

## 2.5 Sample 5

/Prüfmuster  
 /Échantillon  
 /Campione  
 /Especimen  
 /Amostra

Stroke /Hub /Corse /Corsa /Recorrido /Curso	Thrust /Kraft /Force /Forza /Empuje /Esforço
s-[mm]	Th <sub>s</sub> [N]
12,5	9.055
22,5	8.314
32,5	7.466
42,5	6.767
52,5	6.213

**Release pressure at 10 mm stroke** **5,20 [10<sup>2</sup>kPa]**

/Lösedruck bei 10 mm Hub  
 /Pression de desserrage à une course de 10 mm  
 /Pressione di rilascio a una corsa di 10 mm  
 /Presión de descarga a recorrido de 10 mm  
 /Pressão de descarregar em curso de 10 mm



Test Report Nr. /Prüfbericht Nr. /Procès-Verbal d'Essai N° : BC 0092.3  
 /Verbale di Prova N°/Acta de Ensayo N° /Relatório de Ensaio N°  
 Appendix /Anlage /Appendice / Appendice/Appendice/Appendice : 1  
 Sheet /Blatt/Feuille/Foglio /Hoja/Folha : 10 / 10  
 Make /Marke /Marque /Marca/Marca/ Marca : SAF  
 Type /Typ/Type/Tipo/Tipo/Tipo : MM S 1630 A 6 0



## 2.6 Sample 6

*/Prüfmuster*  
*/Échantillon*  
*/Campione*  
*/Especimen*  
*/Amostra*

Stroke /Hub /Corse /Corsa /Recorrido /Curso	Thrust /Kraft /Force /Forza /Empuje /Esforço
s-[mm]	Th <sub>s</sub> [N]
12,5	9.280
22,5	8.574
32,5	7.684
42,5	6.934
52,5	6.607

### Release pressure at 10 mm stroke

**5,10 [10<sup>2</sup>kPa]**

*/Lösedruck bei 10 mm Hub*  
*/Pression de desserrage à une course de 10 mm*  
*/Pressione di rilascio a una corsa di 10 mm*  
*/Presión de descarga a recorrido de 10 mm*  
*/Pressão de descarregar em curso de 10 mm*



Test Report Nr. /Prüfbericht Nr. /Procès-Verbal d'Essai N° : BC 0092.3  
 /Verbale di Prova N°/Acta de Ensayo N° /Relatório de Ensaio N°  
 Appendix /Anlage /Appendice / Appendice/Appendice/Appendice  
 : 2  
 Sheet /Blatt/Feuille/Foglio /Hoja/Folha : 1 / 2  
 Make /Marke /Marque /Marca/Marca/ Marca : SAF  
 Type /Typ/Type/Tipo/Tipo/Tipo : MM S 1630 A 6 0



**V 0.0 Guidance note appended to the report BC00092.xx**

V 0.0 Anlage zum Prüfbericht BC0092.xx

Part <i>Teil</i>	Type <i>Typbezeichnung</i>	Test Report <i>Prüfbericht</i>	Confirmation No <i>Nummer der Bestätigung</i>
SAF Double Diaphragm Spring Brake Cambers for Air Disc brakes <i>SAF Doppelmembranbremszylinder für pneumatische Scheibenbremsen</i>	MMS1630A60	BC0092.xx	190324

Maximum Dimension [mm] <i>Maximale Abmessungen</i>				
A	B	C	D	E
191 <sup>+10</sup>	optional	120.7 +/-10	166 <sup>+10</sup>	257 <sup>+10</sup>

**List of updates**

Änderungsverfolgung

No. <i>Nr.</i>	Date <i>Datum</i>	Doc-Version <i>Dok.-Version</i>	Reason for update <i>Grund der Änderung</i>
A 1.0	05.05.2017	V0.0	Issuing Document <i>Erstellung Dokument</i>

20170504\_TN\_BC\_0092\_2\_MMS1630A60

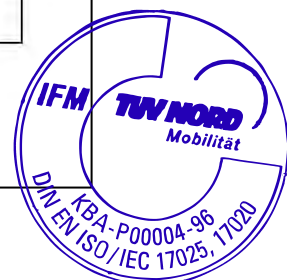



Test Report Nr. / Prüfbericht Nr. / Procès-Verbal d'Essai N°  
 /Verbale di Prova N°/Acta de Ensayo N° /Relatório de Ensaio N°  
 Appendix /Anlage /Appendice / Appendice/Appendice/Appendice  
 Sheet /Blatt/Feuille/Foglio/Hoja/Folha  
 Make /Marke /Marque /Marca/Marca/ Marca  
 Type /Typ/Type/Tipo/Tipo/Tipo

: BC 0092.3  
 : 2  
 : 2 / 2  
 : SAF  
 : MM S 1630 A 6 0

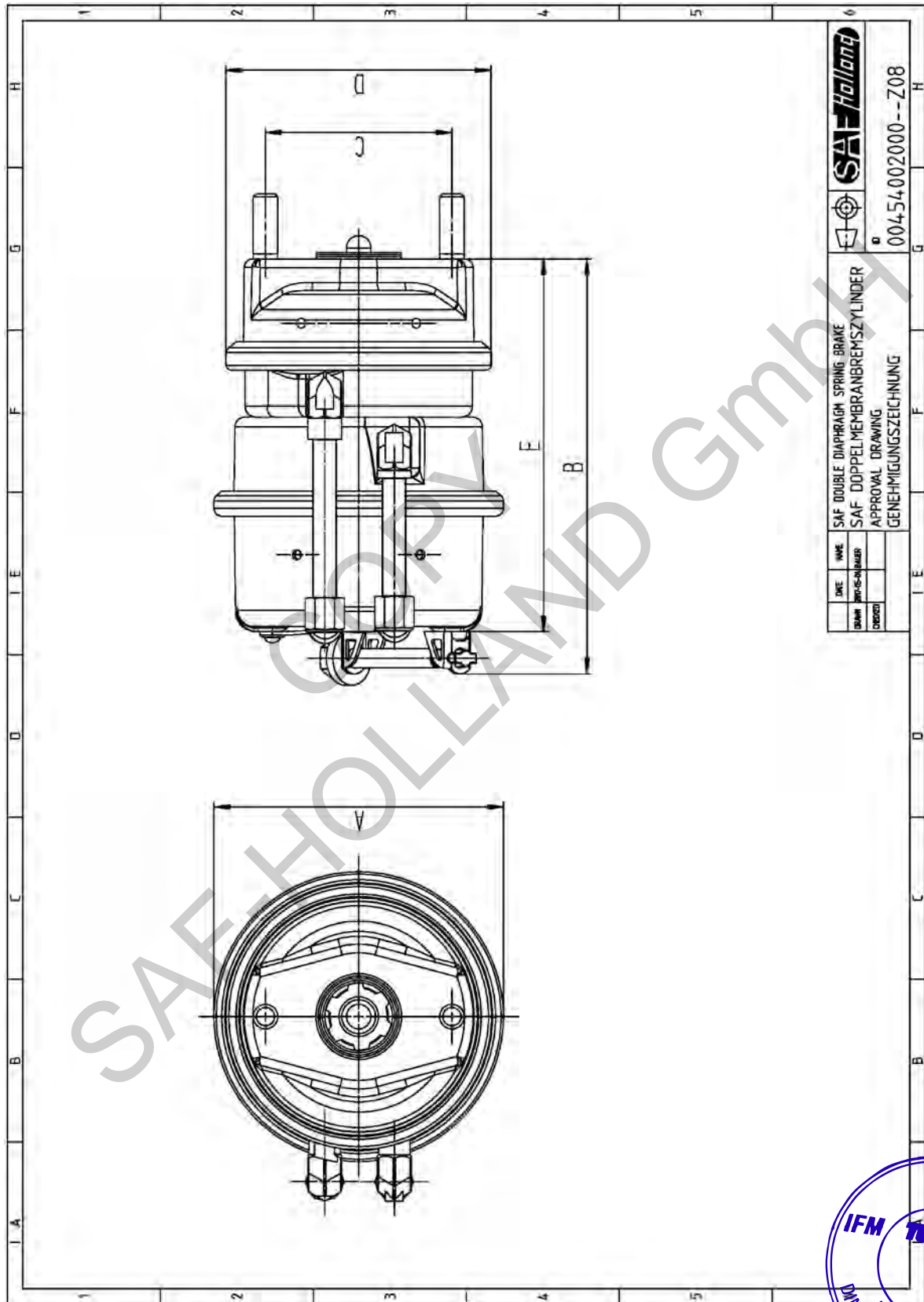

SAF Holland		00454002000--Z08	
LINE	WWE	SAF DOUBLE DIAPHRAGM SPRING BRAKE	APPROVAL DRAWING GENEHMIGUNGSZEICHNUNG
DRAWN	PROJ.-INGENIEUR	SAF DOPPELMEBRANBREMSZYLINDER	
CHECKED			

