

# CO016/26

In-cabin open/closed & steering angle indicators

	A RC00004	B RC00009	C RC00011	D RC00001	E RC00002	F RC00006	G RC00013	H RC00005	I RC00003	L RC00012	M RC00015
1											
2											
3											
4											
5											
6											
7											
8											

1. CO02600 - IN-cabin Open/Closed + Jackknife Remote Indicators
2. CO01601 - IN-cabin Open/Closed Remote Indicators
3. CO01603 - IN-cabin Open Remote Indicator
4. CO01606 - IN-cabin Closed Remote Indicator
5. CO02602 - IN-cabin Jackknife Remote Indicators
6. CO02607 - IN & OUT-cabin Open/Closed + Jackknife Indicators
7. CO02601 - IN & OUT-cabin Open/Closed Remote Indicator
8. CO02605 - OUT-cabin Open/Closed Remote Indicator

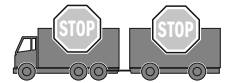

## 2. Wiring Connection Scheme

### CO02600 - CO01601

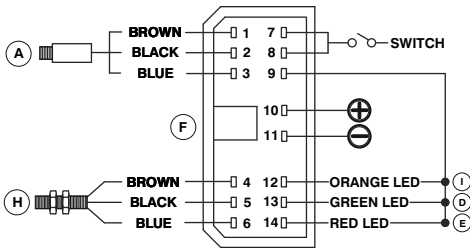

### CO02602

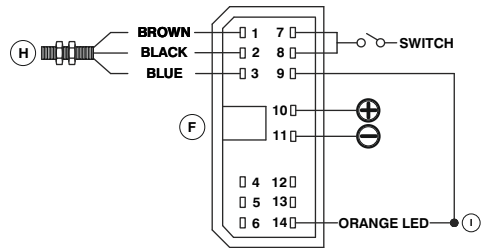

### CO01603

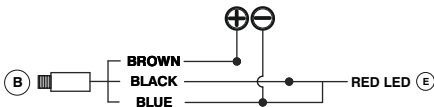

### CO01606

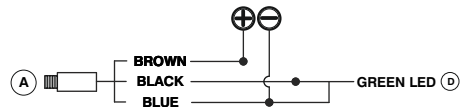

### CO2601 - CO02607

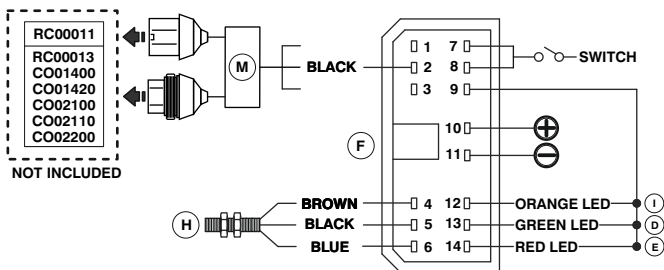

### CO2605

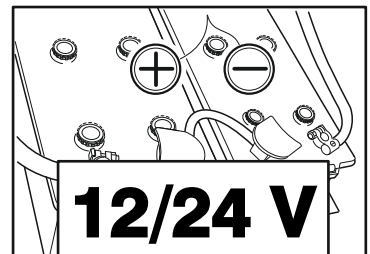
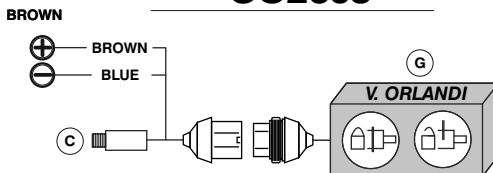

### 3. Assembly Instructions

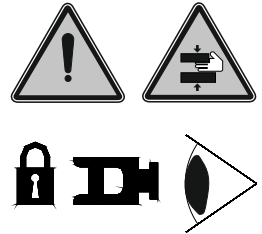
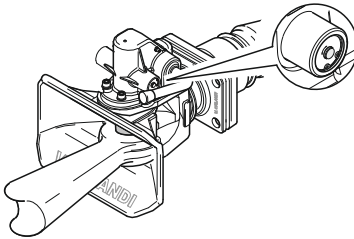
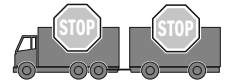

#### 3a. OPEN/CLOSED SENSOR (RC00004 - RC00009 - RC00014)

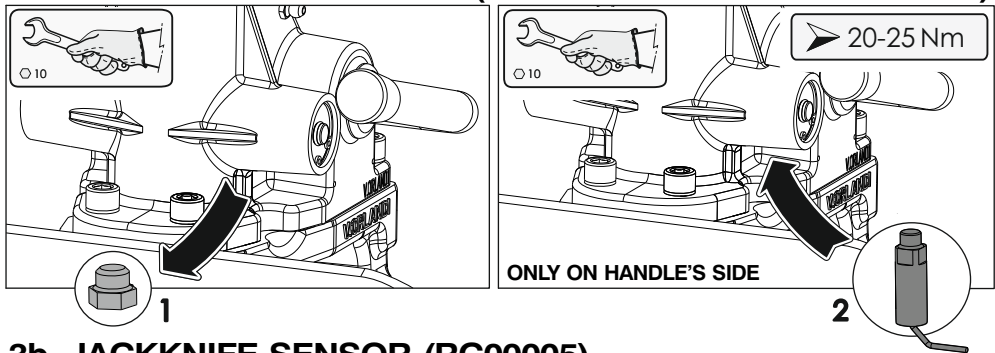

#### 3b. JACKKNIFE SENSOR (RC00005)

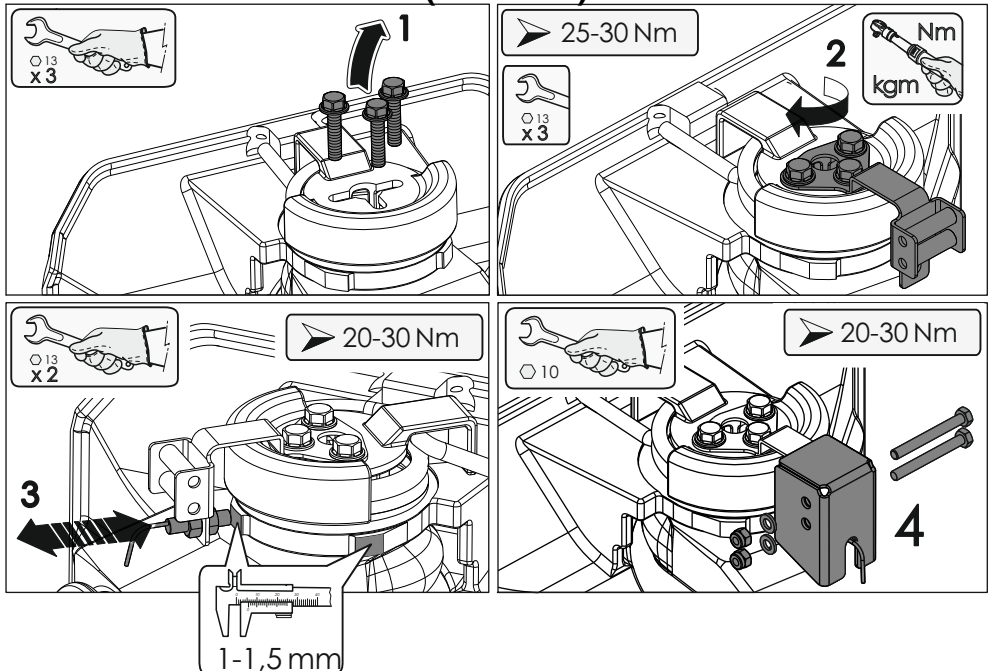

# NOTE

- IT** La V. Orlandi S.p.A. ringrazia la clientela per la scelta del prodotto.  
Per avere informazioni sul Concessionario Ufficiale e/o Centro Assistenza più vicino, consultare il nostro Sito Internet:
- DE** Die Firma V.Orlandi bedankt sich für den Kauf dieses Produkts  
Auf unserer Internet-Site, erhalten Sie weitere Informationen zum offiziellen Vertriebsnetz, sowie des nächstgelegenen Fachhändlers Ihrer Region
- FR** V.Orlandi remercie la clientèle pour le choix du produit.  
Pour toute information concernant la Concessionnaire Officielle et/ou sur le Centre d'Assistance le plus proche, veuillez consulter notre Site Internet :
- GB** The company V.Orlandi thanks the customers for choosing this product.  
Visit our internet site for information of the official distributors or of the nearest workshop.
- ES** V.Orlandi S.p.a. agradece a los clientes la elección de este producto. Para obtener información de los distribuidores oficiales y/o Centro de Servicio más cercano, consulte nuestra página web :
- RU** Компания Orlandi S.p.A. благодарит своих клиентов за сделанный выбор. Для получения информации об официальном дистрибьюторе и/или адресах сервисных центров посетите наш интернет-сайт:
- PL** Firma Orlandi S.p.A. dziękuje klientom za dokonanie zakupu. Żeby uzyskać informacje o oficjalnym dystrybutorze lub adresach serwisów prosimy odwiedzić naszą stronę internetową.
- SE** V. Orlandi S.p.a. tackar för att ni valt den här produkten. Konsultera vår webbsida för mer information om närmaste officiella generalagent och/eller Servicecenter:  
Kräver uppmärksamhet och försiktighet
- SA** شركة v.orlandi s.p.a  
على موقعنا اوزيارة لنا موزع باقرب الاتصال استفسار و لاى انها منتجا لاختيار تشكركم  
نت الانترنت شبكة

Via Quinzano, 3  
25020 Flero -BS- Italy  
tel. +39-0303582722  
fax +39-0303582262  
e-mail: orlandi@orlandi.it  
http: www.orlandi.it

