

EN

**SAF** Holland



# SAFELY ON THE ROAD FOR LONGER WITH SAF TIRE PILOT

IN USE WITH: WITTWER SPEDITION & LOGISTIK GMBH

**WITTWER**  
SPEDITION & LOGISTIK



# SAFELY ON THE ROAD – EVEN WITH A PUNCTURE

Wittwer haulage company cuts costs with SAF-HOLLAND'S SAF TIRE PILOT

All fleet operators wish their vehicles did not have to be taken off the road due to tyre failure. For Georg Wittwer, managing director of the haulage company Wittwer Spedition & Logistik GmbH, the wish has come true: Ever since he started using the SAF TIRE PILOT, SAF-HOLLAND's tyre inflation system for trailers and semi-trailers, to ensure the correct tyre pressure is maintained permanently in his vehicles, Wittwer's articulated vehicles have always arrived safely at their destination, even with a damaged tyre from time to time.

Punctures cost time, money and patience - usually.

"Since fitting our semi-trailers with the SAF TIRE PILOT, we no longer have to worry about punctures when we're on the road", says Georg Wittwer, boss of the Eschenlohe-based haulage company of the same name (Garmisch-Partenkirchen, Bavaria). This is because SAF-HOLLAND's system constantly monitors the tyre pressure, and if the pressure falls, the integrated control box brings it back up automatically to the preset level. Even if a tyre is damaged, the system maintains the minimum pressure of 9.1 bar in the tyre. For the Wittwer haulage company, this means that even when the integrated warning lamp warns the driver of a loss in pressure, he can still rely on the SAF TIRE PILOT automatically topping up the tyre pressure to allow the trailer to reach its destination safely. "In contrast to the situation in the past, high repair costs for tyre failure on the road are eliminated, and we no longer lose valuable time because our vehicle is off the road.



Managing director Georg Wittwer is convinced that the investment in SAF TIRE PILOT for all of his semi-trailers has paid off.

We can postpone the repairs and thus save all the tyres", reports Georg Wittwer from his experience with the pressure control system. His vehicles often transport bulk goods such as metal filings or scrap metal, so that punctures caused by nails or steel pins are nothing unusual.

Around 15 times in the last two years, the SAF TIRE PILOT has warned the haulier's drivers of a puncture. In all cases, the articulated vehicle returned safely and the damaged tyre could be repaired. "Our investment in this tyre inflation system has definitely paid off already", sums up the managing director.



Haulage company boss Georg Wittwer (left) and his driver Hans Leisner swear by the SAF TIRE PILOT, which cuts fuel costs and extends the service life of the tyres.

# REDUCING OPERATING COSTS

Like all fleet operators, you know the two biggest cost drivers in your business: fuel consumption on the one hand, and tyre wear on the other. Anyone who wants to run their business profitably and economically on an ongoing basis needs to recognise the importance of these two factors and the direct correlation between them.



The only way to minimise wear and significantly reduce fuel consumption is by constantly monitoring and consistently maintaining the correct tyre pressure. Which is why SAF-HOLLAND has developed the SAF TIRE PILOT – an intelligent assistant for you and your fleet.

**TIRE**  **PILOT**

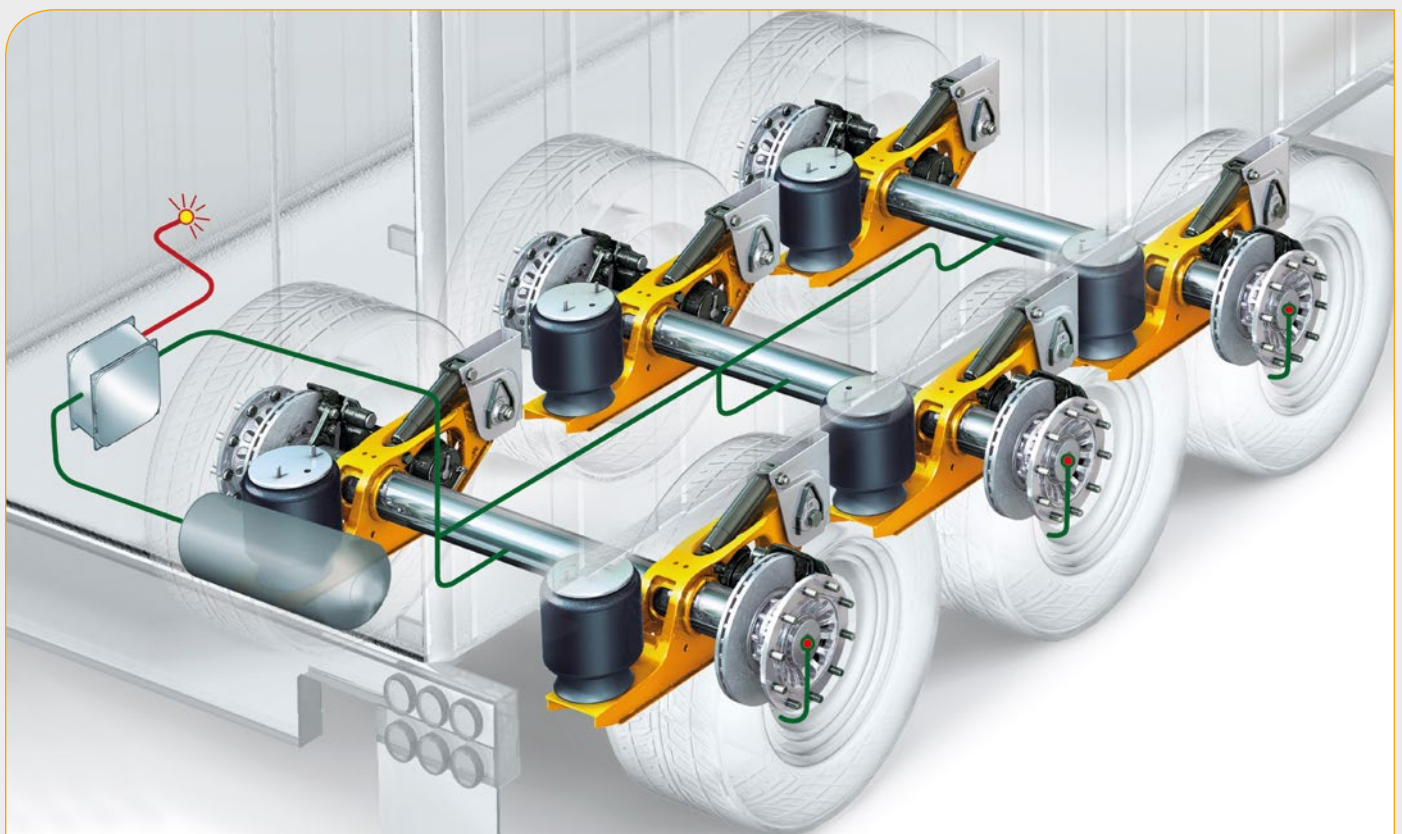



## SUCCESSFUL TRIAL WITH THE SAF TIRE PILOT

The haulier Wittwer Spedition & Logistik GmbH has been transporting anything from rolls of paper to spare parts for the automotive industry or even grain throughout Europe since 1974. In their headquarters in Eschenlohe in Upper Bavaria and the two branches in Italy and Bulgaria, they employ a total of 242 people, including 163 drivers.

"I had seen the SAF TIRE PILOT on another vehicle, was interested, and asked SAF-HOLLAND for further information. What really impressed me was the fact that the system not only recognises the loss in performance, but automatically readjusts the tyre pressure to compensate for it", says Georg Wittwer.

A subsequent trial with five semi-trailers was so successful that he ordered all 150 semi-trailers currently deployed in the fleet with the pressure regulation system ex factory.

"SINCE FITTING OUR SEMI-TRAILERS WITH THE SAF TIRE PILOT, WE NO LONGER HAVE TO WORRY ABOUT PUNCTURES WHEN ON THE ROAD."

Georg Wittwer, managing director



For axles and fifth wheels, Rüdiger Wittwer now relies exclusively on SAF-HOLLAND products. The Wittwer workshop manager's experience with the SAF TIRE PILOT has also always been good.

The installation necessitated the drilling of a special hole in the steering knuckle of the steering axle – to supply the SAF TIRE PILOT with air. The SAF TIRE PILOT monitors the tyre pressure constantly, and if the pressure drops too low, a warning light warns the driver. The integrated control box automatically readjusts the pressure to the preset level and consistently maintains the minimum pressure of 9.1 bar in the tyre in the event of a puncture. The control box generates the electrical energy required itself, eliminating the need for a complicated cable connection to the trailer wiring system.

# €1,100 SAVINGS PER YEAR\*

This system allows savings of up to €1,100 annually, assuming 100,000 km coverage. In practical terms, this means:

- ➔ €200 due to reduced tyre wear
- ➔ €340 due to the prevention of punctures
- ➔ €120 due to saved maintenance costs for tyre pressure monitoring
- ➔ €440 due to reduced fuel consumption

\* Sample calculation; for further information, please visit <http://tirepilot.safholland.com>

## Always an open ear for fleet operators

For Georg Wittwer, the SAF TIRE PILOT, which he has installed in the particularly economical SAF INTRADISC *plus INTEGRAL* axle in all semi-trailers, was just the prelude to his cooperation with the supplier to the commercial vehicle industry.

"I have 100% faith in SAF-HOLLAND. Their customer service is outstanding, and the more I get to know the company, the more impressed I am by their excellent products", he declares. Among other products, the international haulier now also uses the zinc sprayed axle in his fleet, specially designed to prevent weather- and dirt-related corrosion damage. The premium landing gear system Titan Pro, which has long rendered good service in the semi-trailers, is now gradually being replaced by the new, particularly robust SAF Hercules landing gear system.

"What I like about this landing gear is that it is not too rigid, it offers sufficient flexibility, and it is able to absorb many knocks", Georg Wittwer praises. He also considers SAF-HOLLAND's fifth wheels to be very well thought out. In future new acquisitions, the light-weight, low-maintenance SK-S 36.20 W in spheroidal graphite cast iron is to be fitted, permitting coupling and uncoupling with one hand. The key to the shared success of SAF-HOLLAND and the Wittwer haulage company is the excellent working relationship between them: "We take our customers seriously and have an open ear for their requirements in all new developments. We thus attach great importance to providing haulage companies and fleet operators with comprehensive information and allowing them to trial our products", says Oliver Beierlorzger, sales manager OEM in southern Germany & Austria for SAF-HOLLAND.

## Cutting costs on fuel and tyres

The SAF TIRE PILOT not only saves time and money in the event of tyre failure, but also pays off during normal operations. If the tyre pressure in your articulated vehicles is consistently maintained at the correct level, it reduces diesel consumption and thus fuel costs. In a 40-ton semi-trailer truck, for example, the rolling resistance of the tyres accounts for around 16% of the diesel consumption. Around 50% of the rolling resistance is caused by the tyres on the trailer.

Still more savings potential for fleet operators: the service life of the tyres is also extended. "We drive on very high quality and thus also very expensive tyres. But the investment pays off, because the automatic pressure regulation by the SAF TIRE PILOT permits us to drive an additional two years on the same tyres", the haulier explains.

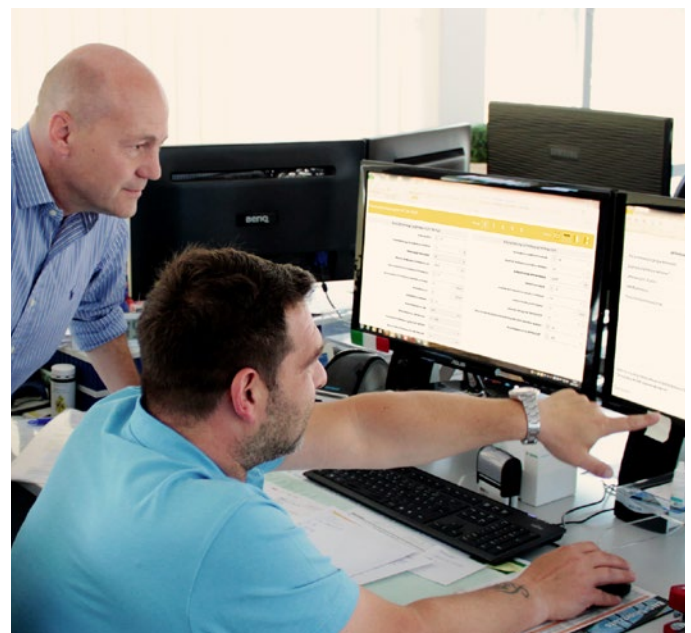

The day-to-day operations of a haulage company require a lot of planning and coordination. Since Wittwer GmbH has been using the SAF TIRE PILOT, wasted time and material losses due to tyre failure are history.

Monitoring the tyre pressure using the SAF TIRE PILOT is a simple and efficient way for Wittwer Spedition & Logistik GmbH to reduce the operating costs of their fleet and absorb tyre failure without material losses or loss of time. This convenient tyre-inflation system not only saves diesel, but also reduces wear in the tyres of the semi-trailer, extending their service life and reducing the failure risk of the entire tractor-trailer unit.



TRAILER AXLES AND  
SUSPENSION SYSTEMS



COUPLING AND  
LIFTING TECHNOLOGY



SUSPENSIONS FOR  
TRUCKS AND BUSES