



# FIFTH WHEELS

## INSTALLATION INSTRUCTIONS SLIDER MOUNTINGS



### Holland Eurohitch Fifth Wheels

Installation Instructions Covering 7000, 7100, 8000 and 9000 series Slider Mountings

### GENERAL INFORMATION



#### WARNING

Failure to read, understand and follow the important information contained in these instructions may result in a hazardous condition or cause a hazardous condition to develop



#### WARNING

When welding, use a procedure which assures a sound, good quality weld and which protects operators and others. Overwelding may cause distortion and damage, and underwelding may not develop sufficient strength.

Welding procedures EN499-E 42 0 RR 1 2 (electrode) or EN440-G 42 0 G3Si1 (gas) are recommended. Take precautions to ensure that the tractor electrical system is not damaged during the welding process.

### FIFTH WHEEL DESIGN AND INTENDED USE

#### Holland Fifth Wheels are Designed and Intended to be Used :

1. For pulling trailers with standard ISO king pins which are in good condition and securely mounted or locked in position in the trailer
2. Within the capacities stated in Holland literature
3. As recommended in Holland literature (available from Holland and/or Holland distributors)

#### Holland Fifth Wheels are NOT Designed or Intended For :

1. Use with non-ISO king pins, such as king pins which are bent, improper size or dimensions, not secured to maintain ISO configuration, or which are installed in warped trailer skidplates
2. Tow-away operations which damage or interfere with the proper operation of the fifth wheel
3. The attachment of lifting devices
4. The transportation of loads in excess of rated capacity
5. Applications other than recommended

### RATINGS AND CAPACITIES

The tractor/trailer combination to be operated must be within the Gross Combination Weight, Vertical Load and D-Value Capacities given in the Holland specification for the fifth wheel concerned.

To calculate the D-value for a tractor and semi-trailer combination use the following formula

$$D = g \times \frac{0.6 \times T \times R}{T + R - U} \quad (\text{kN})$$

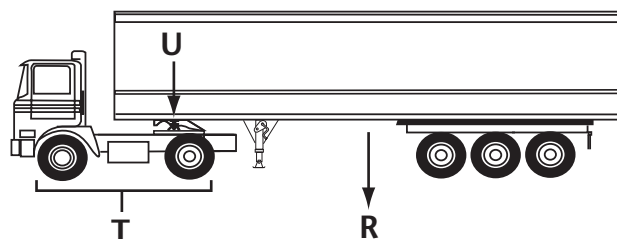

**T** = Weight of towing vehicle including the vertical load on the fifth wheel

**R** = Total weight of the loaded semi-trailer

**U** = Vertical load on the fifth wheel

**g** = Acceleration due to gravity (assumed to be 9.81 m/s<sup>2</sup>)

#### Example calculation :

**T = 17** (Tractor weight 7t plus vertical load 10t)

**R = 33** (10t imposed on fifth wheel and 23t

**U = 10** on rear bogie)

**g = 9.81**

$$D = 9.81 \times \frac{0.6 \times 17 \times 33}{17 + 33 - 10} \quad (\text{kN})$$

**D-Value = 82.55 kN**

The above calculation represents a 2 axle tractor with tri-axle trailer operating at a GCW of 40000 kg

For safe operation the D-value calculated must not exceed the D-value rating of the Fifth Wheel and/or King Pin

## GENERAL RECOMMENDATIONS

1. Every user and installer using Holland products either recommended or not recommended by Holland, must thoroughly satisfy himself that the installation procedure used is appropriate for the vehicle, product and application
2. Consult the Holland literature for fifth wheel capacities and applications
3. Consult the tractor manufacturers instructions and any applicable government and/or transport department guidelines and regulations where the vehicle is to be registered and/or operated
4. Determine the range of proper fifth wheel positions which are important for weight distribution, swing clearance and handling characteristics. consult the tractor manufacturers recommendations



With the sliding fifth wheel in its rearmost position the centre of the king pin locks must always be positioned on or ahead of the tractor rear axle or bogie centre line

5. Bolt holes can be 2 mm larger in diameter than the bolt fastener. Bolts must be adequately tightened using charted torque ranges in Nm for the recommended grade and size of bolts used

## INSTALLATION



The installation of the fifth wheel and mounting plate on the vehicle must conform to EC regulation 94/20 EG appendix VII, (see appendix I, No. 5.10)

**NOTE:** *These instructions are based on the tractor unit being fitted with outboard 'L' profile mounting angles (flitch plates). Please contact Holland Europe if your tractor unit is not fitted with mounting angles*

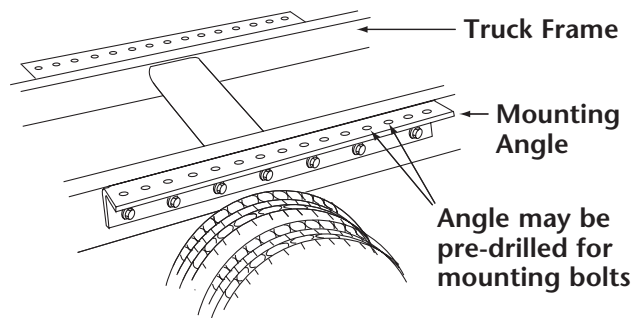

In addition to these recommendations, all fifth wheel mounting plate installations must be made in accordance with all applicable government regulations where the vehicle is registered and/or operated.

## 7000 SERIES SLIDE PLATES

1. The 7000 series slide plate requires the fabrication and attachment of a subframe or mounting plates / angles to enable it to be bolted to the truck chassis
2. The subframe should be manufactured by approved chassis engineers in accordance with local regulations and truck manufacturers recommendations in addition to the guidance given in this document
3. For operation up to 44000 kg GCW the subframe should be bolted to the chassis mounting angles using a minimum of 6 bolts per side, M16 grade 8.8 (minimum) or grade 10.9 equally spaced along the subframe
4. For operation above 44000 kg GCW and up to 65000 kg GCW the subframe should be bolted to the chassis using a minimum of 8 bolts per side, M16 grade 8.8 (minimum) or grade 10.9 equally spaced along the subframe



Modifications to the slider base plate other than those noted in these instructions is prohibited without the express authorization of Holland Europe

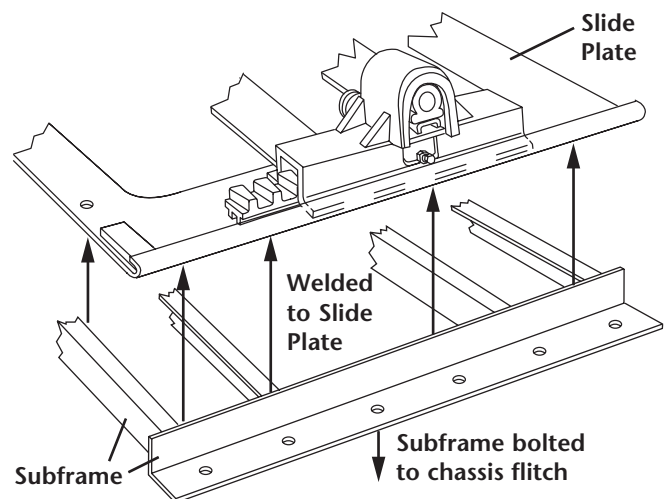

Alternative flat plate mounting which can be used when the truck chassis is wide enough to allow drilling and bolting outside of the width of the slide plate

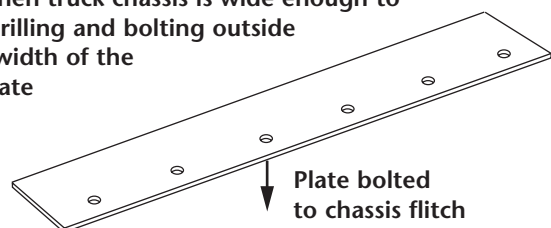

Two plates required, one each side, welded to the underside of the slide plate

## 7100 SERIES SLIDE PLATES

The 7100 series slide plate should be mounted in the same way as the 7000 series, however, please note the following :

1. The 7100 series is a heavy duty slide plate which can be used at up to 110000 kg GCW and therefore will require additional bolts at these higher operating weights

**CONSULT THE TRUCK MANUFACTURER !**

2. For operation above 65000 kg some truck manufacturers require an extended subframe to be fitted to spread the load along the truck frame

**CONSULT THE TRUCK MANUFACTURER !**

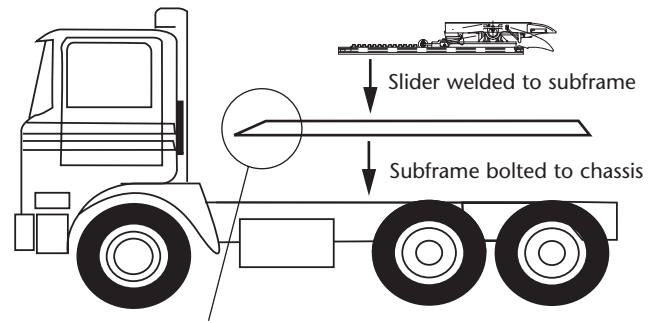

A flexible body style mounting is normally used at the front end of the extended subframe to prevent excessive stress in the tractor frame

## 8000 and 9000 SERIES SLIDE PLATES

1. The 8000 and 9000 series slide plates are designed for bolting directly on to the truck chassis mounting angles and are available with different hole patterns and hole sizes to suit all European tractor units. Ensure that the hole pattern on the slider supplied is compatible with the chassis
2. The subframe should be bolted to the chassis using the size of bolt to suit the pre-drilled hole pattern in the slide plate. The bolts used should be grade 8.8 minimum and all holes in the slide plate must be used.
3. Certain hole patterns to suit narrow chassis will require the use of countersunk bolts, these should also be a minimum grade of 8.8

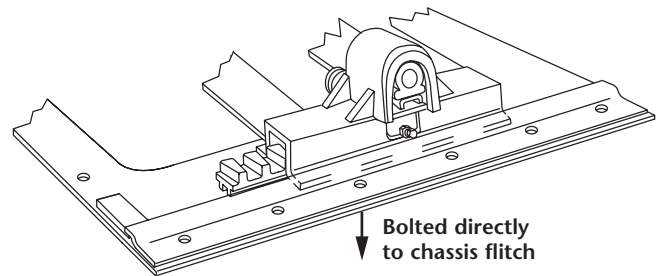

## INSTALLATION OF SLIDE STOPS

It is the responsibility of the installer to ensure that slide stops are installed properly at all four corners of the slide plate. Front stops are normally installed by Holland during manufacturing

### 7000 and 8000 series - Weld on Stops:

1. Slide the bracket to the full rear position and engage the plungers in the rack
2. Locate rear stops under the curled edge allowing some clearance to the bracket (approximately 3 mm) and clamp in place. This should position the stops approx. 6 to 12 mm from the rear edge of the plate
3. Slide bracket forward, out of the way and weld the stops in place as shown opposite. The welds should be 8 mm fillet
4. Slide bracket to full rear position and check for clearance. Make sure that the plungers on the sliding bracket seat properly into the rack with all teeth engaged
5. Repaint and lubricate as required

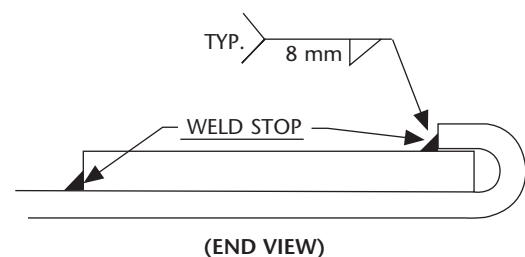
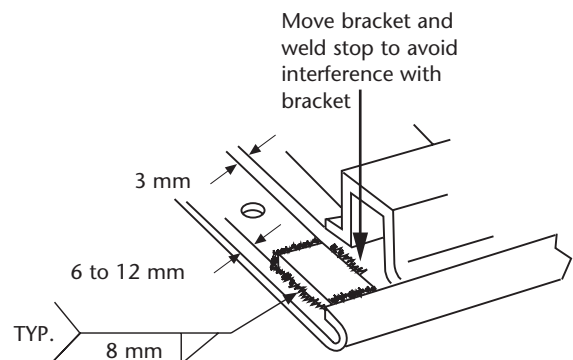

**WARNING**

Review welding procedure given on page 1 of these instructions

## INSTALLATION OF SLIDE STOPS (continued)

### 9000 series - Bolt on Stops

The 9000 series slider is supplied with bolt on slide stops at the rear of the slider. The installer should ensure that they are fitted and that the bolts are correctly tightened when the installation is complete

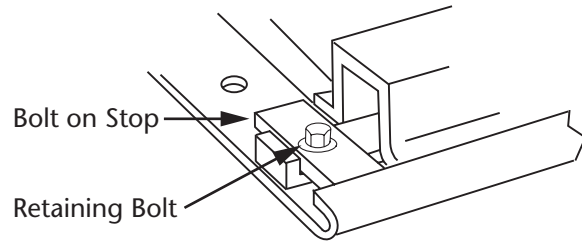

## ADJUSTMENT OF SLIDING BRACKET LOCKING PLUNGERS

Your slider locking plungers are given an initial adjustment during factory assembly. However, due to variations introduced during mounting (such as frame and material tolerances) a further check of the adjustment is required at installation. Adjust again after one month of use and as recommended. To adjust locking plungers :

1. Loosen lock nut and turn adjusting bolt out anti-clockwise (see illustration opposite)
2. Disengage and engage the locking plungers. Check that plungers are securely seated without binding.
3. Turn adjusting bolt in (clockwise) until it contacts the rack. Turn bolt an additional 1/2 turn then tighten lock nut securely

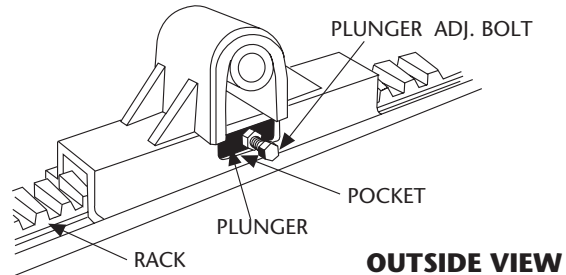

Proper adjustment is required for proper operation, load transfer and distribution. Correct adjustment must be carried out at installation and regular intervals by use of adjusting bolts on both sides

## AIR OPERATED SLIDE RELEASE

Where the slider is fitted with an air operated release mechanism Holland air control kit RK-2500-10-A should be used and installed in accordance with the instructions provided with the kit, please note the following :

1. Mount cab control valve where it is readily accessible to the driver but protected from accidental activation
2. Feed from an air source recommended by the tractor manufacturer and use approved fitting and air lines of suitable pressure rating.
3. Check operation of valve and cylinder after installation

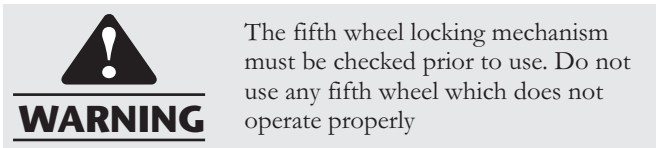

**IMPORTANT NOTE : PLEASE ENSURE THAT THE FIFTH WHEEL OPERATING MANUAL SUPPLIED WITH THE FIFTH WHEEL IS PASSED ON TO THE OPERATOR AND THAT IT IS READ AND UNDERSTOOD BY THE OPERATOR AND DRIVERS**

Contact Holland for additional copies if required

## INSPECTION AND LUBRICATION

The fifth wheel must be given a final inspection and be fully lubricated before going into service.

1. Review the installation. Be sure that all nuts and bolts are in place and properly tightened. Be sure that all necessary steps were followed and that any components removed to facilitate installation are reinstalled
2. Check the fifth wheel locking mechanism with a Holland lock tester and examine for proper locking as described in the *Fifth Wheel Operating Manual* supplied with your fifth wheel. This must be done to ensure that the fifth wheel has not been damaged during shipment or installation
3. Lubricate all moving parts with a light oil.
4. Apply grease to bearing surface of mounting bracket where applicable and where a grease fitting is provided on the fifth wheel pocket. The top plate should be lifted up to relieve weight on the bracket while the grease is applied. (not required on fifth wheels fitted with pocket inserts)
5. On standard fifth wheels apply a generous coating of grease to the top surface of the fifth wheel where it will contact the trailer skidplate. On low maintenance fifth wheels fitted with wear pads coat the wear pads with a light oil to assist the bedding in process

Copyright © June 2004 • The Holland Group Inc.



The Holland Group, Inc.  
Holland, MI 49423  
United States  
Phone: (616) 396-6501  
Fax: (616) 396-1511

EN ISO  
9001:2000



Certified  
Company

#### Holland Europe GmbH

Altenkamp 9  
D-33758  
Schloss Holte-Stukenbrock  
Germany  
Phone: +49 (0) 5207-89560  
Fax: +49 (0) 5207-895656

#### Holland Eurohitch Ltd.

Hoo Farm Industrial Estate  
Worcester Road  
Kidderminster  
Worcestershire  
DY11 7RA  
Phone: +44 (0) 1562-732010  
Fax: +44 (0) 1562-732020

#### Holland Hitch (Aust.) Pty. Ltd.

Melton, Victoria, Australia  
Phone: 61-(0)3-9743-6799  
Fax: 61-(0)3-9747-9617

#### Holland Transtrade

(Thailand) Company, Ltd.  
Bangkok, Thailand  
Phone: 66 (0)2-513-8758  
Fax: 66 (0)2-513-8757

#### Nippon Holland, Ltd.

Tokyo, Japan  
Phone: 81-(0)3-3461-9130  
Fax: 81-(0)3-3463-1407

#### Holland Transtrade

Far East SDN BHD  
Shah Alam, Malaysia  
Phone: 60 (0)3 734-2888  
Fax: 60 (0)3 736-5588