

## Repair Instructions

### Compressed Air Disc Brake

SAF SBS 2220 H0

SAF SBS 1918 H0

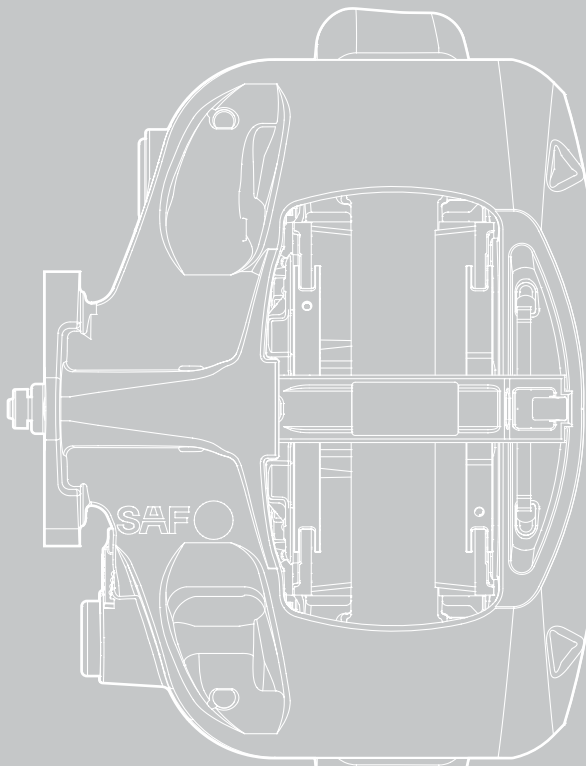

## Please note

These repair instructions are intended for the exclusive use by trained persons within the commercial vehicle industry and related workshops.

The content of this manual is not all-inclusive and not legally binding. SAF-HOLLAND GmbH assumes no liability as a result of its use. The information contained in this manual neither represents ensured characteristics of the product nor a guarantee. SAF-HOLLAND GmbH reserves the right to make changes in the interest of technical progress without prior notice.

No liability is assumed as a result of incorrect or inappropriate components being fitted to the product or the omission of appropriate tests after the servicing of the product. Use appropriate spare parts documentation when obtaining spare parts. Use only genuine SAF-HOLLAND GmbH spare parts in repairs.

This manual is subject to the copyright of SAF-HOLLAND GmbH. All rights reserved. No part of this manual may be reproduced, copied or translated in any form or by any means without the prior written permission of SAF-HOLLAND GmbH. Brand names mentioned in this manual are not identified as such in all cases, but they are nevertheless subject to the provisions of trademark legislation.

In case of conflicting language versions of this manual, the German original prevails.

The failure of any individual provision of this disclaimer to comply with current legal provisions does not affect the validity of the remaining provisions.

## Copyright

These repair instructions are classified as in accordance with the law on unfair competition.

All rights reserved by

SAF-HOLLAND GmbH  
Hauptstraße 26  
63856 Bessenbach, Germany

These repair instructions contain text and drawings that without the express permission of the manufacturer cannot be either fully or partly

duplicated,

distributed or

in any other way disclosed.

Any breach or infringement will result in liability for damage.

## Table of contents

<b>1</b>	<b>Introduction .....</b>	<b>5</b>	4.3.10	Checking the thrust plate bellows .....	20
1.1	General information.....	5	4.3.11	Checking the slide function .....	21
1.1.1	Type plate.....	5	4.3.12	Measuring the bearing clearance.....	21
1.1.2	Spare parts.....	5	<b>5</b>	<b>Replacement procedure .....</b>	<b>23</b>
1.2	Functional description .....	6	5.1	General information.....	23
<b>2</b>	<b>Safety precautions .....</b>	<b>6</b>	5.2	Replacing the brake pads .....	23
2.1	General information.....	6	5.2.1	Initial procedure.....	23
2.2	Installation .....	7	5.2.2	Removing the brake pads .....	23
2.3	Setting the control system/valves.....	7	5.2.3	Installing the brake pads .....	24
2.3.1	Before entering the vehicle into service.....	7	5.2.4	Final procedure .....	25
2.3.2	Replacing spare parts .....	7	5.3	Replacing the brake chamber .....	25
2.3.3	Brake force distribution .....	7	5.3.1	Initial procedure.....	25
2.4	Brake chamber.....	7	5.3.2	Removing the brake chamber .....	25
2.5	Recycling.....	8	5.3.3	Installing the brake chamber .....	26
2.6	Cleaning .....	8	5.3.4	Final procedure .....	27
2.7	Surface finishing of the disc brake .....	8	5.4	Replacing the adjustment screw bellows .....	27
2.7.1	Painting .....	8	5.4.1	Initial procedure.....	27
2.7.2	Shot blasting .....	8	5.4.2	Removing the adjustment screw bellows .....	27
<b>3</b>	<b>Initial and final procedures.....</b>	<b>8</b>	5.4.3	Cleaning.....	28
3.1	General information.....	8	5.4.4	Final procedure .....	29
3.2	Initial procedure.....	8	5.5	Replacing the slide function assembly ..	30
3.2.1	Lifting and supporting the vehicle axle.....	8	5.5.1	Initial procedure.....	30
3.2.2	Removing the wheel.....	9	5.5.2	Removing the slide function assembly .....	30
3.3	Function test.....	9	5.5.3	Cleaning.....	32
3.3.1	Checking the adjustment unit.....	9	5.5.4	Installing the slide function assembly ..	32
3.4	Final procedure .....	11	5.5.5	Final procedure .....	35
3.4.1	Mounting the wheel .....	11	5.6	Fully replacing the reset shaft .....	35
3.4.2	Lowering the vehicle axle.....	11	5.6.1	Initial procedure.....	35
<b>4</b>	<b>Inspection procedures.....</b>	<b>13</b>	5.6.2	Fully removing the reset shaft .....	35
4.1	General information.....	13	5.6.3	Fully installing the reset shaft.....	35
4.2	Inspection intervals .....	13	5.6.4	Final procedure .....	36
4.3	Inspections .....	14	5.7	Replacing the disc brake.....	36
4.3.1	Daily visual inspection.....	14	5.7.1	Initial procedure.....	36
4.3.2	Checking the overall condition .....	14	5.7.2	Removing the disc brake.....	36
4.3.3	Checking brake pad wear .....	14	5.7.3	Installing the disc brake.....	36
4.3.4	General brake pad clearance check ..	15	5.7.4	Final procedure .....	37
4.3.5	Checking the brake disc.....	16	<b>6</b>	<b>Specifications .....</b>	<b>37</b>
4.3.6	Plugs and protective caps check.....	16	6.1	Wear limits.....	38
4.3.7	Checking the thrust plate guide pins..	17	6.2	Tightening torques.....	38
4.3.8	Checking the actuation interface.....	18	6.2.1	General .....	38
4.3.9	Checking the guide pin bellows.....	19	6.2.2	SAF SBS 2220/SBS 1918 H0 .....	38

<b>7</b>	<b>Tools .....</b>	<b>38</b>
7.1	SAF special tool for SBS 2220 H0 .....	38
<b>8</b>	<b>Fault finding.....</b>	<b>39</b>
8.1	General fault finding instructions.....	39
8.2	Inspection intervals .....	39
<b>9</b>	<b>Spare parts and repair kit list.....</b>	<b>40</b>



# 1 Introduction

## 1.1 General information

The SAF SBS 2220/SBS 1918 H0 repair instructions are divided up into chapters. The sequence of the chapters is structured in such a way as to make the instructions easy for the user to read and simple to follow.

Chapter "1. Introduction" provides a general overview of these repair instructions and of the SAF SBS 2220/SBS 1918 H0 compressed-air disc brake.

It is important to carefully read chapter "2. Safety precautions" before starting any workshop procedures. This is to inform the user about the safety precautions and the potentially hazardous situations which, if not avoided, could result in serious injury or death!

Chapter "3. Initial and final procedures" describes the start and finish activities necessary to be able to carry out inspection and replacement work. It also describes the function test for the SAF SBS 2220/SBS 1918 H0 compressed-air disc brake.

Consult chapter "4. Inspection procedures" for information and instructions on inspecting the SAF SBS 2220/SBS 1918 H0 compressed-air disc brake. Chapter "4.2. Inspection intervals" details the recommended compressed-air disc brake inspection intervals. In this chapter, the inspection intervals table displays how frequently the different brake components should be inspected and on which pages the check instructions are to be found.

If any inspection shows that a replacement activity needs to be performed, continue to the appropriate section in chapter "5. Replacement procedures".

Chapter "6. Specifications" contains technical data for the SAF SBS 2220/SBS 1918 H0 compressed-air disc brake.

Chapter "7. Tools" contains information about the SAF SBS 2220/SBS 1918 H0 tool kit, which is essential for carrying out much of the replacement procedure work described in this manual.

Chapter "8. Fault finding" should be used to help with the self diagnosis of any problem being experienced.

Chapter "9. Components list" lists and shows what spare part components are available for the SAF SBS 2220 / SBS 1918 H0 compressed-air disc brake.

### 1.1.1 Type plate



Fig. 1 - Type plate

**Type** Type designation of the brake calliper

**P/N** Production number of the brake calliper

**S/N** Serial number of the brake calliper

### 1.1.2 Spare parts

It is vital that only SAF-HOLLAND original spare parts are used during all repair work.

The use of non-original spare parts can affect the function, performance and/or service life of the components.

The use of non-original spare parts will immediately terminate any warranty of the disc brake unit.

## 1.2 Functional description

The SAF SBS2220 H0 comprises a monobloc floating calliper (item C) and an integrated adjustment unit, which compensates for the brake pad wear.

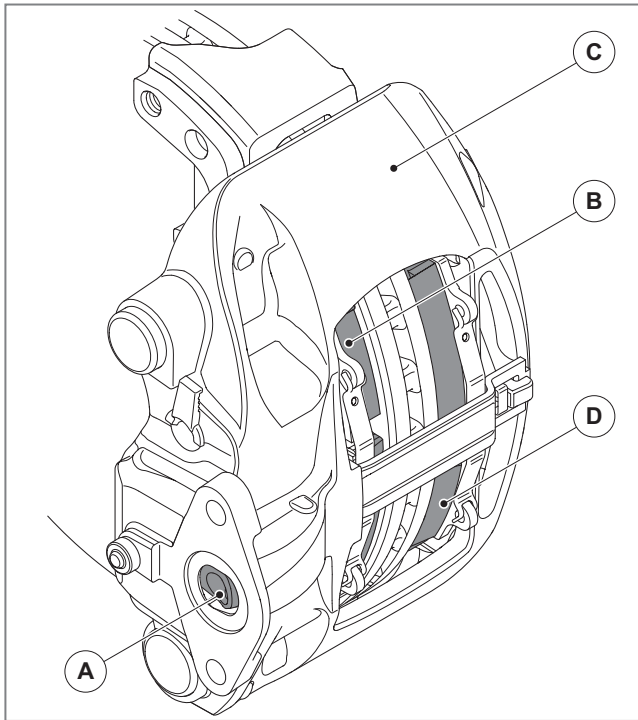

Fig. 2 - Functional description

The unit, which is actuated by the lever mechanism (item A), presses the inner brake pad (item B) against the disc, which then causes the brake calliper (item C) to slide laterally. In so doing, the outer brake pad (item D) comes into contact with the disc.

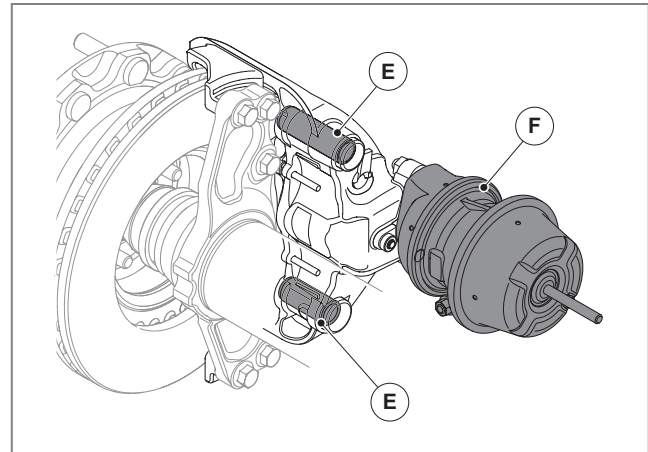

Fig. 3 - Guide pin and spring brake chamber

The brake calliper moves on the guide pins (item E) (see If the disc brake also serves as a parking brake, the unit is actuated with the aid of a spring brake chamber (item F).

## 2 Safety precautions

### 2.1 General information

This chapter details the safety precautions that must be read and followed before any inspection/repair/installation procedure described in these repair instructions is started. These repair instructions are intended for the exclusive use of trained persons within the commercial vehicle industry and related workshops.

Three different alert levels are used throughout these repair instructions:

- **Danger**
- **Caution**
- **Note**

The following symbols are used to denote particularly important information and sections of the text. Ensure that they are always read and adhered to before working with the product.



#### **Danger!**

This safety instruction with the signal word warns of a possible safety risk or serious and fatal injury!



#### **Caution!**

This safety instruction with the signal word warns of possible damage to the product!



#### **Note:**

Marking for special user tips and other particularly useful and important information for efficient work and economical use.

## 2.2 Installation

The disc brake must not be installed or treated in such a way that exposes it to excessive thermal, mechanical or chemical influences that can cause a reduced braking effect or damage to vital components in the brakes.

These influences/damages may result in a shortened service life for the disc brake and its components, reduced brake effect or at worst, total brake failure.

## 2.3 Setting the control system/valves

Failure to follow the instructions in this chapter may accelerate the wear to the brake pads and may cause damage/repeated damage to the disc brake, axle and/or wheel brake components.

### 2.3.1 Before entering the vehicle into service

Prior to initial use, a vehicle's disc brake compressed-air brake unit must be checked and adjusted (if necessary) in accordance with the relevant brake calculations. Contact the vehicle manufacturer for relevant information.

### 2.3.2 Replacing spare parts

Always use spare parts that are approved for the vehicle, axle or disc brake. On replacement of any essential components or spare parts in the disc brake system (e.g. brake valves or control units), the disc brake system must also be checked and adjusted (if necessary) in accordance with the relevant brake calculations.

### 2.3.3 Brake force distribution

It is very important that the distribution of brake force, between axles/vehicles, in a vehicle combination is adapted so that the brake force for each axle/vehicle is proportioned in accordance with the legally applied brake calculations.

If the brake force is not correctly distributed, it can lead to excessive braking of a vehicle and/or one or more axles in the combination. This can result in overheating, accelerated wear and damage to the disc brake, pads, brake discs, tyres and wheel components.

Before a vehicle is entered into service, it must be set up in accordance with the specified values in the relevant brake calculation. After the pads/brake discs have been run in for a period of around 3,000 to 5,000 km, the brake force distribution between the truck/tractor and trailer must be checked and adjusted (if necessary). The same also applies to repair and replacement of parts if there is any suspicion that heat/overheating has caused to damage to the axle/brake components (e.g. seals, hub/wheel bearings and brake disc).

Contact the vehicle manufacturer for information on the appropriate action.

Failure to follow these instructions may cause damage/repeated damage to the disc brake, axle and/or wheel brake components.

## 2.4 Brake chamber

Dirt/water ingress into the disc brake mechanism housing could affect the function of the brake and as a result shorten its service life.

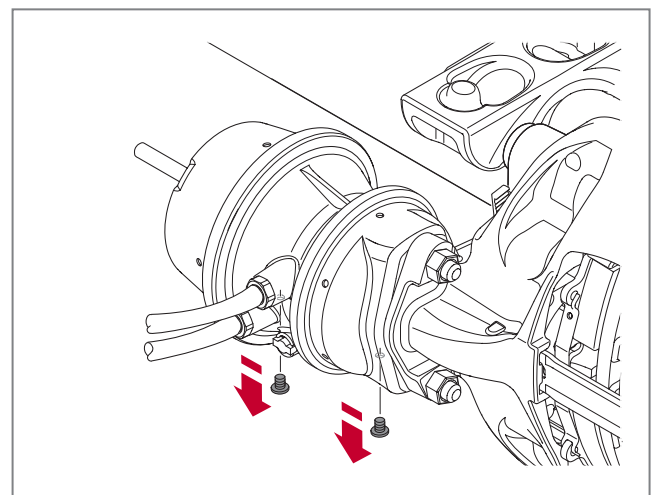

Fig. 4 - Venting hole

Therefore, to prevent water ingress, it is important that the brake chamber is of the correct design and that the seal between the brake chamber and disc brake mating surfaces is undamaged and correctly in place.

It is also important for the disc brake's function that the brake chamber housing is correctly vented.

To this end, the downward-facing drain holes must be opened as a minimum, see ► Fig. 4. Other drain plugs can remain in position in the brake chamber housing.



### Caution!

If the venting holes remain closed, the brake chamber and disc brake may not operate correctly.

## 2.5 Recycling

When replacing the disc brake or components thereof, the components removed must be recycled/destroyed in accordance with applicable environmental legislation, regulations and provisions.

## 2.6 Cleaning

For the disc brake to function correctly, it is important to keep the calliper free from ice and snow and to ensure that it remains clean so as not to restrict its movement. Damage may cause direct brake failure or damp/dirt penetration resulting in malfunction/shortening of the service life of the disc brake.



### Caution!

Take care when using chemicals and/or cleaning tools (e.g. knives, brushes, etc.). This to avoid damage or displacement of hoses, seals and other components.

## 2.7 Surface finishing of the disc brake

### 2.7.1 Painting

The disc brake can be finished with paint that has trade approval for this purpose (automotive paint). It must be ensured that the paint layer does not cause damage and/or restrict the natural movement/function of the disc brake. All contact surfaces, pad material and rubber parts must therefore be protected or masked.

The following areas must not be painted:

- bellows,
- Reset shaft and its protective plug,
- complete brake pads,
- disc surface,
- the disc brake mounting surfaces to axle/brake chamber, and
- all bolted connections.

### 2.7.2 Shot blasting



### Caution!

Failure to follow the Instructions below could jeopardise safety and/or reduce the service life of the disc brake and its components.

If the vehicle is shot blasted, all rubber parts and pads on the disc brake must be protected, as well as all areas in which the pads are seated. The brake chamber must be fitted (or any protective parts that have a similar sealing function). The shipping seal fitted to the brake chamber aperture on a new disc brake does not provide adequate protection during shot blasting.



### Note:

Follow the recommendations of the brake chamber manufacturer.

The disc brake must be thoroughly cleaned after shot blasting to ensure that its natural movement is not obstructed by remnants of shot-blasting material. Check the seals/rubber parts to ensure that they have not been damaged.

# 3 Initial and final procedures

## 3.1 General information

The objective of this chapter is to give guidelines on how initial and final procedures should be performed in a standardised way.

The initial procedure is a recurring procedure that must be performed prior to the inspections and/or repairs covered in this service manual.

The final procedure is a recurring procedure that must be performed after the inspections and/or replacements covered in this service manual.

## 3.2 Initial procedure

### 3.2.1 Lifting and supporting the vehicle axle



### Danger!

- At least one of the vehicle's axles must be chocked in order to prevent involuntary movement of the vehicle!
- The vehicle manufacturer's safety precautions must be followed when working on the vehicle!
- Local safety precautions must be observed!

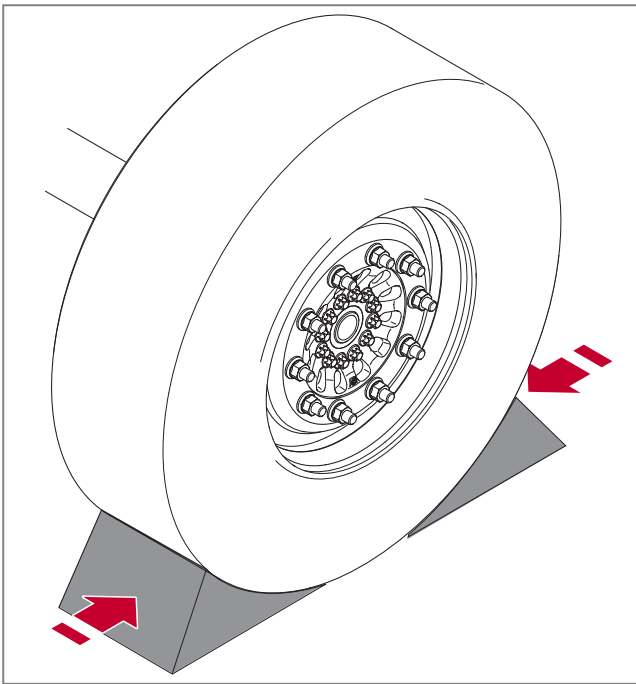

**Fig. 5 - Securing the wheels**

1. Secure the wheels on a flat and level surface, see ► *Fig. 5*
2. Lift the axles and place on stands.



**Danger!**

If the disc brake is equipped with a parking brake function, ensure that the brake system is depressurised, that the spring brake chamber is fully disengaged and mechanically secured in this position. See the vehicle manufacturer's instructions.

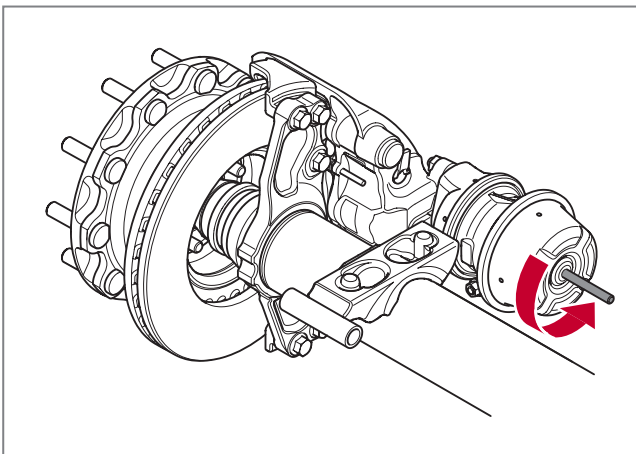

**Fig. 6 - Securing with the extraction tool**

3. Release the parking brake

**3.2.2 Removing the wheel**



**Danger!**

- Take all necessary safety precautions before wheel removal!
- The vehicle manufacturer's safety precautions must be followed!

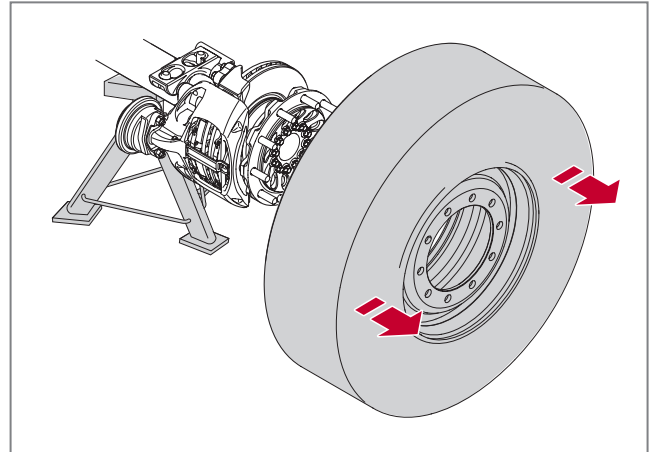

**Fig. 7 - Removing the wheel**

1. Check the free rolling resistance. If the resistance is higher than expected, tap the tyre to remove any normal rest tension. If the wheel still does not rotate freely then consult chapter „8 *Fault finding*“ on what action to take.
2. Remove the wheel nuts followed by the wheel, see ► *Fig. 7*.

**3.3 Function test**

**3.3.1 Checking the adjustment unit**



**Note:**

The function test can be carried out with the wheel either fitted or removed.

1. Check that the wheel/hub can rotate freely. If it does not then first tap to remove any rest tension. If the wheel still does not rotate freely then consult chapter "8. *Fault finding*" on what action to take.
2. Remove the reset shaft protective plug (item A), see ► *Fig. 8*



**Caution!**

- Use recommended tools only!
- Never use an impact wrench or similar to rotate the reset shaft. Doing so could damage the internal components of the mechanism! The maximum torque is 20 Nm.
- Dirt must not be allowed to enter the aperture of the reset shaft.
- Use a vacuum cleaner to clean the surfaces. Do not use compressed-air.
- Take care when using chemicals and/or cleaning tools (e.g. knives, brushes, etc.). This to avoid damage or displacement of hoses, seals and other components.

**Note:**

The Torx 55 and thrust plate must be allowed to move unhindered!

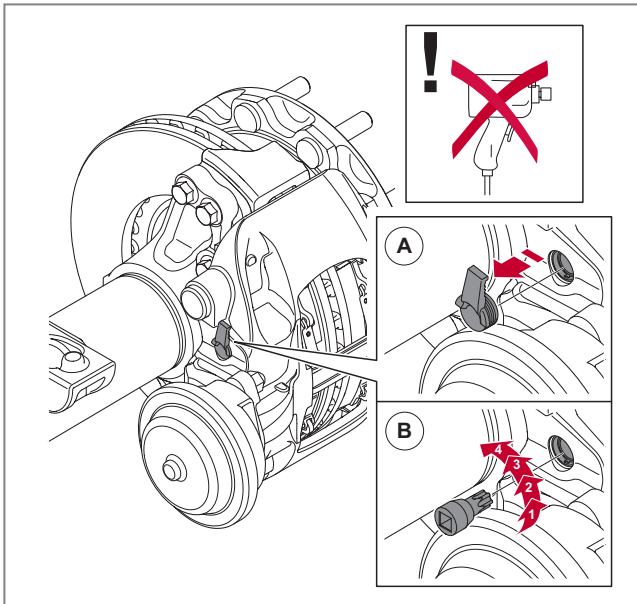

Fig. 8 - De-adjusting with the reset shaft

3. Using a Torx 55 socket, de-adjust the brake by rotating the reset shaft anti-clockwise by 4 clicks, or until the end stop, see item B, see ► Fig. 8. A clicking sound must be heard and felt when de-adjusting.

**Caution!**

- When reaching the end stop position of de-adjustment, never tighten and leave. Leaving the reset shaft tightened in the de-adjust position could stop the adjustment function from working!
- After reaching the end stop position, always then adjust by rotating the reset shaft clockwise 90 degrees, thus activating the adjustment function.

4. Leave the Torx 55 in position in the reset shaft.

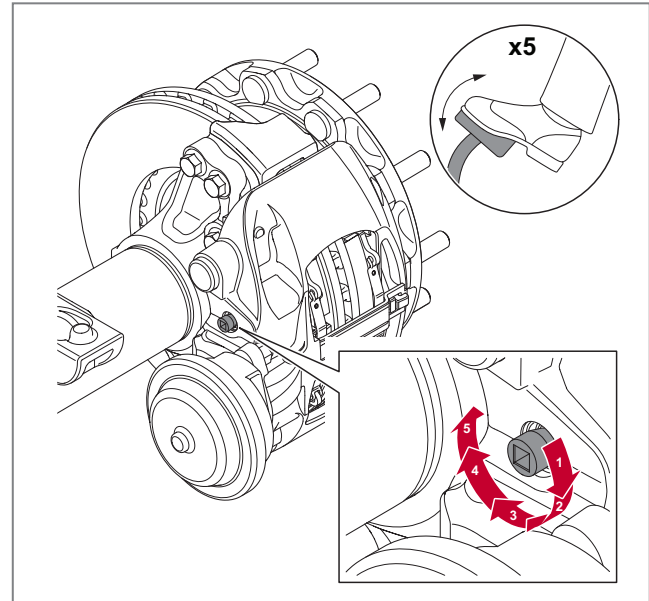

Fig. 9 - Brake actuation

5. Actuate the brakes five times by pressing and releasing the vehicle brake pedal through its full stroke, see ► Fig. 9. If no brake chamber is fitted then actuate the brake chamber lever manually with a suitable tool.
6. The Torx 55 must rotate clockwise on each actuation, showing that the automatic adjustment function is working.
7. If the Torx 55 rotates back and forth or not at all, then the adjustment function is not working correctly.
8. To check further, manually adjust the reset shaft. Rotate the Torx 55 clockwise 360 degrees, and then anti-clockwise 180 degrees. In so doing, ensure that the adjuster is not jammed at the full de-adjust position.
9. Observe the following. Once the excessive clearance is taken up by the adjuster, the Torx 55 will suddenly stop rotating. If in doubt, rotate the Torx 55 anti-clockwise 180 degrees and then press the brake pedal again to check.

10. If the Torx 55 still rotates back and forth during actuation, then the adjustment function is defective and the brake calliper must be replaced.

See chapter „5.7 Replacing the disc brake“.

### 3.4 Final procedure

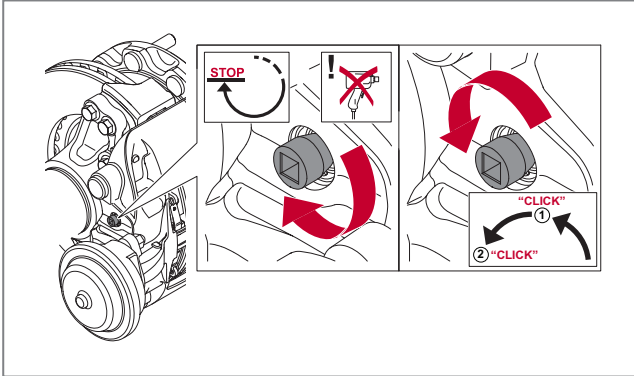

Fig. 10 - Basic setting

1. Use the Torx 55 socket to manually rotate the reset shaft clockwise until it stops, so that the brake pads lie on the brake disc.
2. Then rotate the reset shaft 2 clicks anti-clockwise, see ► Fig. 10. That is the procedure for the basic setting after successful repair or brake pad change.

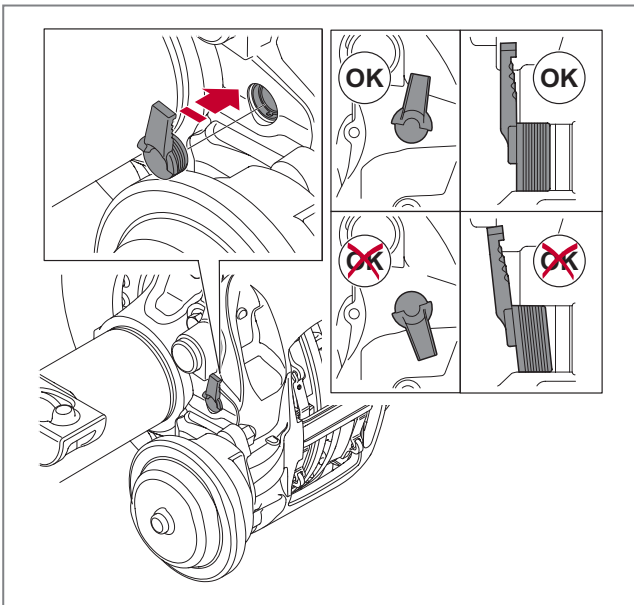

Fig. 11 - Correctly fitting the protective plug



#### Note:

The SAF guarantee of competence shall be made void in the event of improper fitting of the reset shaft protective plug and resulting damage.

3. Fit the reset shaft protective plug on the brake calliper and verify that it is correctly aligned and fully in the correct sealing position. Failure to do so may compromise the service life of the brake! see ► Fig. 11

#### 3.4.1 Mounting the wheel



#### Danger!

Ensure that the brake hoses are in good condition and that they are laid/ducted and fastened correctly.

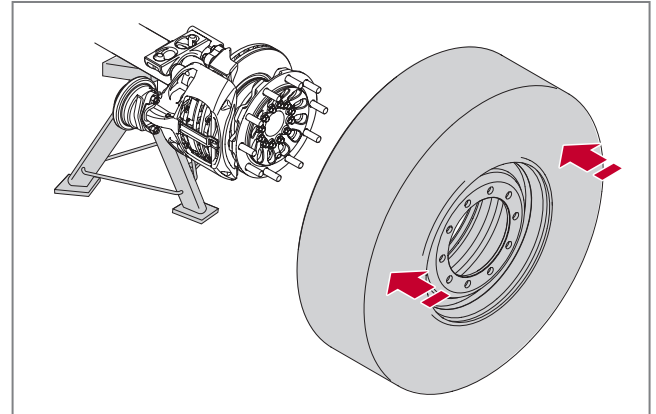

Fig. 12 - Mounting the wheel

1. Check the free rolling resistance. The disc brake must not be obstructed in any way.
2. Mount the wheel, see ► Fig. 12

#### 3.4.2 Lowering the vehicle axle



#### Danger!

If the disc brake is equipped with a spring brake chamber, ensure that the brake system is pressurised, that the spring brake chamber is fully vented and that the mechanical lock has been removed. See the vehicle manufacturer's instructions.



#### Caution!

Actuate the parking brake. Ensure that there is sufficient pressure in the system (min. 6 bar).

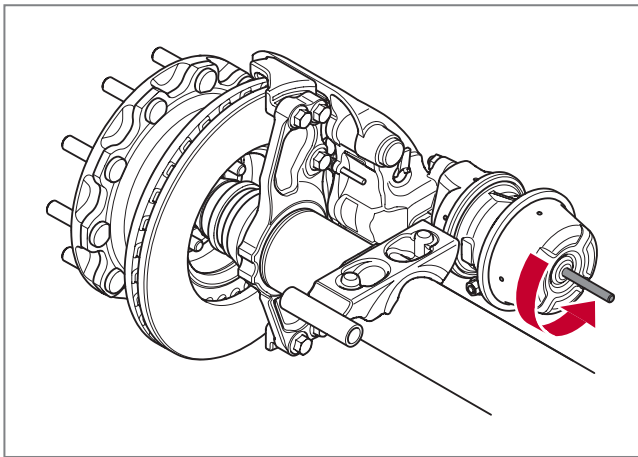

Fig. 13 - Removing the extraction tool

1. Activate the parking brake if fitted with a spring brake chamber.
2. Lift the axles so that the stands can be removed.
3. Carefully lower the vehicle to the ground.

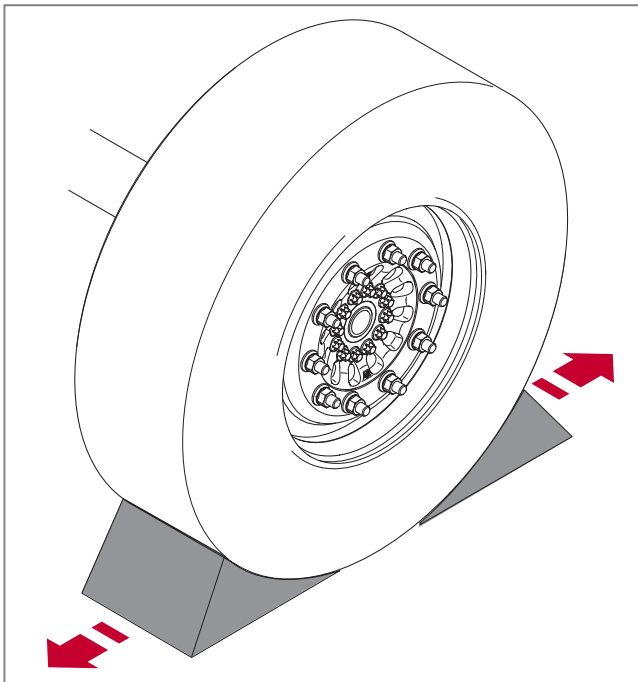

Fig. 14 - Removing the wheel blocks

4. Remove the wheel blocks.



### Danger!

Work performed must always be completed with a function test (► *chapter 3.3*) and a test drive in order to ensure that the brakes are functioning correctly.

► *chapter 3.3*



## 4 Inspection procedures

### 4.1 General information

The objective of this chapter is to give guidance on how inspection of the brake components should be conducted. Always start by consulting the inspection interval table in chapter „4.2 Inspection intervals“.

The table indicates how frequently the different brake components should be inspected and on which pages the check instructions are found.

For the majority of inspections, the wheel should be removed from the vehicle. Before removing the wheel, read chapter „2 Safety precautions“ and „3 Initial and final procedures“.

### 4.2 Inspection intervals

The inspection intervals specified in the table below are maximum intervals. Depending on the vehicle application, type of driving, adjustment to the vehicle manufacturer's service/inspection intervals etc., there may be a need for more frequent inspections.

#### Inspection intervals

	Before starting to use vehicle	Daily	After 3,000 to 5,000 km	Every 3 months	Every 12 months	If components are replaced in the system	See page
1 = Function test 2 = Setting 3 = Visual inspection							
Setting the control system/valves	1/2	–	–	–	–	1/2	► chapter 2.3
Braking force distribution tractor/trailer	–	–	1/2	–	–	1/2	► chapter 2.3.3
Safety check	–	1	–	–	–	–	► chapter 4.3.1
Brake pads	–	–	–	3	–	–	► chapter 4.3.3
Brake disc	–	–	–	3	–	–	► chapter 4.3.5
Function test	–	–	–	–	1	–	► chapter 3.3
Plugs and protective caps	–	–	–	–	3	–	► chapter 4.3.6
Thrust plate guide pins	–	–	–	–	3	–	► chapter 4.3.7
Guide pin bellows	–	–	–	–	3	–	► chapter 4.3.9
Thrust plate bellows	–	–	–	–	3	–	► chapter 4.3.10
Slide function	–	–	–	–	1	–	► chapter 4.3.11

## 4.3 Inspections

### 4.3.1 Daily visual inspection



#### Danger!

Contact the Service Workshop immediately if there is any sign of reduced performance or if the brakes do not work properly.

1. Check that the brakes function properly before driving and that they work effectively and smoothly.
2. Check that the service and parking brake function is effective by trying to drive the vehicle with the service and parking brake applied.

### 4.3.2 Checking the overall condition

1. Ensure that you have good lighting conditions.
2. Inspect the visible parts of the brake and its components. Pay particular attention to:
  - damage,
  - collection of debris,
  - corrosion,
  - signs of overheating,
  - cracks in the brake discs,
  - unusual wear etc.,
  - corrosion on the friction surface of the brake disc, etc.

### 4.3.3 Checking brake pad wear



#### Danger!

Wear respiratory protection in order to avoid inhaling particles which can be hazardous to health! Brake pad wear produces dust which can cause lung damage!



#### Note:

Step 1 in this procedure only indicates the brake pad wear of the outer brake pad! For a full examination, complete all steps.

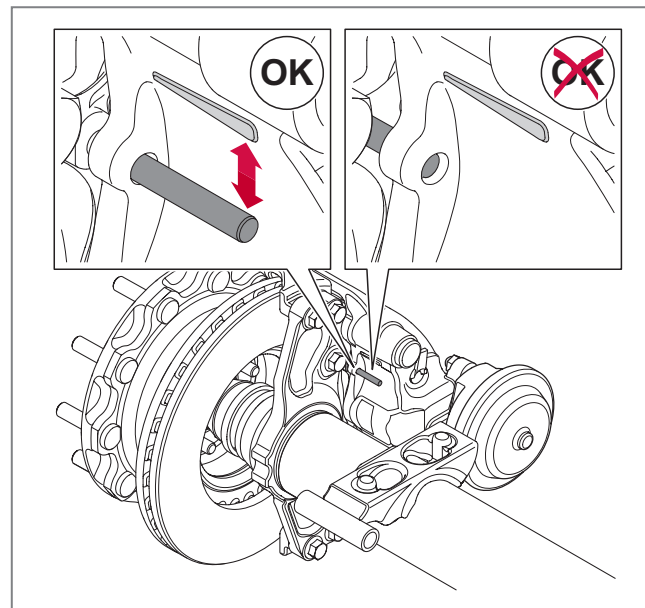

Fig. 15 - Inspection of the visual wear indicator

1. Inspect the position of the visual wear indicator (VWI), see ► Fig. 15. This check can be completed with either the wheel fitted or removed. The VWI provides an indication of the pad wear condition, but it does not provide an accurate measurement of pad wear on both pads. To obtain an accurate wear measurement of both pads, continue with the following instructions.
2. Remove the wheel in accordance with ► chapter 3.2.
3. Remove the brake pads in accordance with ► chapter 5.2.2.
4. Look for unusual conditions such as excessive corrosion and high heat cycles, i.e. delamination, discolouration, etc. If found, carry out the relevant measures, see chapter „8.2 Inspection intervals“.

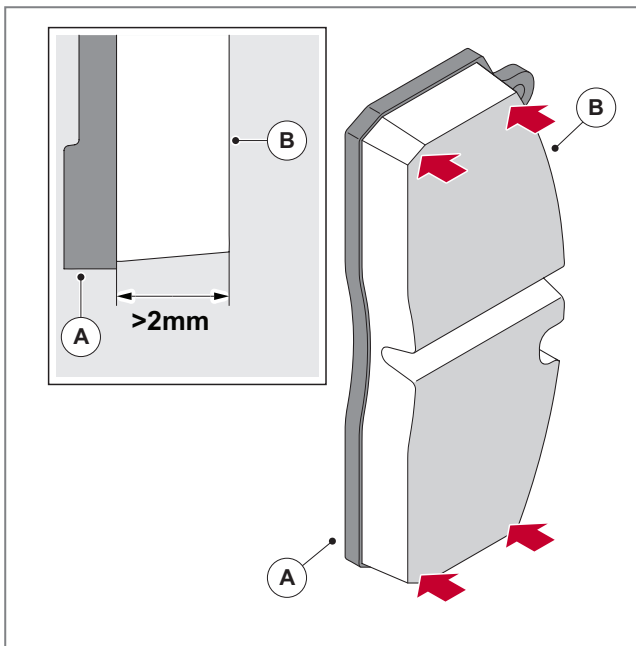

Fig. 16 - Measuring brake pad wear

- On both brake pads, measure the distance from the back plate (A) to the wear surface (B) of the brake pad in four places, see ► Fig. 16. The minimum permitted pad thickness (friction material) is 2 mm.



**Danger!**

Failure to comply poses a risk of the pad back plate becoming lost, which could endanger individuals.

The SAF guarantee of competence shall be made void in the event of the minimum pad thickness not being met and if damage results.

- Check the condition of the back plate (A).
- Replace the brake pads if they are worn out or if they are expected to be so before the next inspection. For replacement follow the instructions in chapter „5.2 Replacing the brake pads“.
- Once the inspection is completed satisfactorily, conclude by following chapters „5.2.3 Installing the brake pads“ and „5.2.4 Final procedure“.



**Note:**

This brake disc inspection check procedure is only a general guide. Refer to the vehicle manufacturer's documentation for specific brake disc information and instructions.

**4.3.4 General brake pad clearance check**



**Danger!**

Wear respiratory protection in order to avoid inhaling particles which can be hazardous to health! Brake pad wear produces dust which can cause lung damage!



**Note:**

- The clearance can be checked with the brake chamber fitted or removed.
- This check is best performed after the wheel is removed and before the reset shaft is retracted. For this situation, steps 2 and 3 below can be skipped.

- Read and follow chapter „3.2 Initial procedure“ and „5.2.2 Removing the brake pads“ prior to checking the clearance.
- Reduce the clearance by inserting and manually rotating the Torx 55 socket clockwise until it comes to a stop. The excessive clearance is hereby rectified. Now set the correct clearance by rotating 270° anti-clockwise.
- Activate the brake until the Torx 55 bolt no longer rotates because any excessive clearance has been removed by the adjustment function.

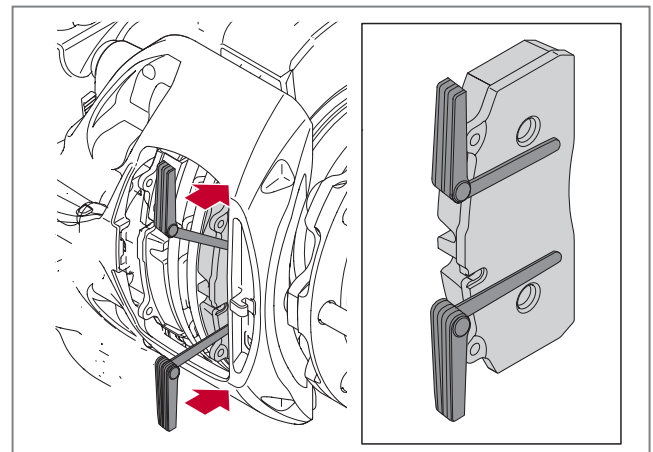

Fig. 17 - Correct location of the feeler gauges

- Insert two feeler gauges in between the brake calliper and the outer brake pad to measure the clearance. Position the feeler gauges in the upper and lower part of the brake pad back plate so that the axial clearance can be measured, see ► Fig. 17.
- The normal clearance is between 0.7 mm and 1.1 mm. If the measurement is outside of the normal running condition then continue with chapter „8.2 Inspection intervals“.

6. Once the inspection is completed satisfactorily, conclude by reading and following „5.2.3 *Installing the brake pads*“ and all of chapter „5.2.4 *Final procedure*“.

#### 4.3.5 Checking the brake disc



#### Danger!

Wear respiratory protection in order to avoid inhaling particles which can be hazardous to health! Brake pad wear produces dust which can cause lung damage!

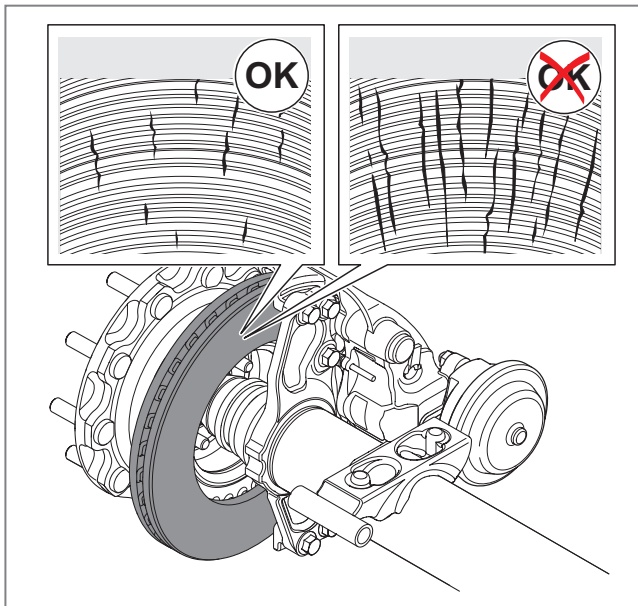

Fig. 18 - Inspection of the brake disc

1. Look for wear, damage and cracks, see ► Fig. 18. Cracks that enter the cooling ducts via the outer circumference or on the inner diameter of the friction ring are not permitted!

Acceptable crack length	Unacceptable crack length
<75% of brake disc width	>75% of brake disc width

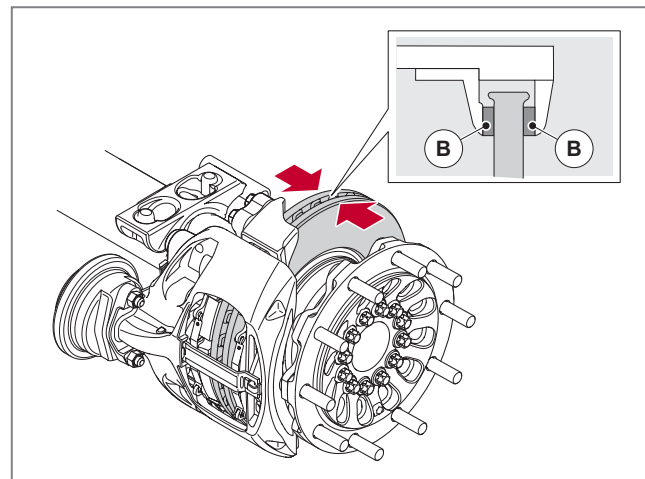

Fig. 19 - Measuring the brake disc thickness

2. Measure the thickness of the brake disc using a calliper. If the brake disc has a wear ridge, the measurement can be performed using two spacers (B; e.g. 5 mm thick flat washers), see ► Fig. 19. Reduce the measured dimension by the total thickness of the two spacers (B).

The minimum thickness of the brake disc is 37 mm.

Replace the brake disc if it is worn or if it is expected to be so before the next inspection.

#### 4.3.6 Plugs and protective caps check



#### Danger!

Wear respiratory protection in order to avoid inhaling particles which can be hazardous to health! Brake pad wear produces dust which can cause lung damage!



#### Caution!

- Use a vacuum cleaner to clean the surfaces. Do not use compressed-air.
  - Failure to follow the instructions below could compromise safety and/or reduce the service life of the disc brake and its components.
1. Read and follow „3.2 *Initial procedure*“ prior to inspecting the protective plugs and protective caps.
  2. Remove dirt from surfaces if necessary.
  3. Check for signs of excessive heat exposure, discolouration, debris, etc.

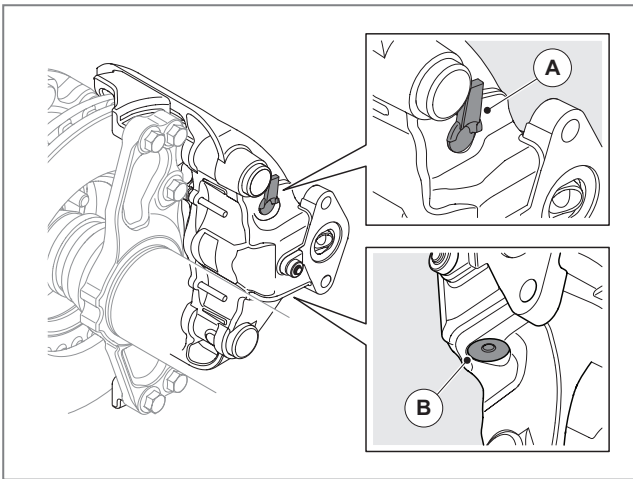

Fig. 20 - Two protective plugs

4. The following plugs and protective caps must be in place and intact:

- The reset shaft protective plug (A) and brake calliper seal (B), see ► Fig. 20,
- The housing seal (b) must not be removed.

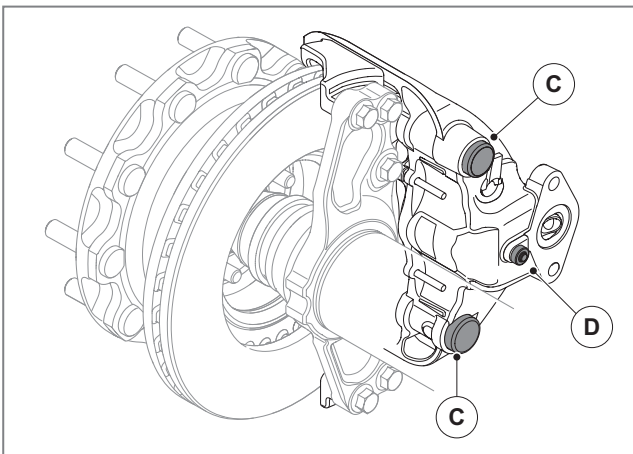

Fig. 21 - Two protective caps

5. Two protective caps to protect the guide pins (C), see ► Fig. 21.
6. Once the inspection is completed satisfactorily, conclude by reading and following chapter „3.4 Final procedure“.



**Caution!**

Never remove the housing seal (B), see ► Fig. 20.  
If the housing seal (B) is removed, it will void the warranty and compromise the disc brake!  
The nut (D) must not be adjusted, see ► Fig. 21.

**4.3.7 Checking the thrust plate guide pins**



**Danger!**

Wear respiratory protection in order to avoid inhaling particles which can be hazardous to health! Brake pad wear produces dust which can cause lung damage!



**Caution!**

Use a vacuum cleaner to clean the surfaces. Do not use compressed-air.

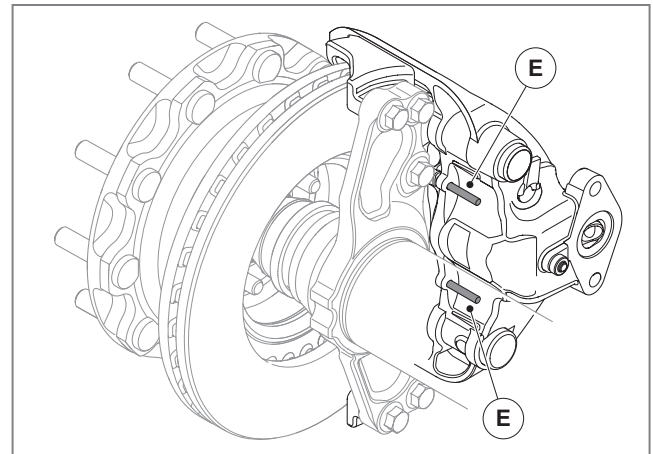

Fig. 22 - The two thrust plate guide pins

1. Read and follow „3.2 Initial procedure“ prior to inspecting the thrust plate guide pins.
2. Remove dirt from surfaces as necessary.
3. Check that the two thrust plate guide pins (E) are in their correct position, see ► Fig. 22.
4. Check that the thrust plate with guide pins are free to move without obstruction.
5. Once the inspection is completed satisfactorily, conclude by reading and following chapter „3.4 Final procedure“.



### 4.3.8 Checking the actuation interface



#### Danger!

- Wear respiratory protection in order to avoid inhaling particles which can be hazardous to health! Brake pad wear produces dust which can cause lung damage!
- Pressure from lines and components must be released before they are opened!
- If a brake chamber is installed with a spring mechanism, it must be ensured that the spring is mechanically safeguarded during removal, see chapter „3.2.1 Lifting and supporting the vehicle axle“.



#### Caution!

- Take care when using chemicals and/or cleaning tools (e.g. knives, brushes, etc.). This to avoid damage or displacement of hoses, seals and other components.
- Use a vacuum cleaner to clean the surfaces. Do not use compressed-air.

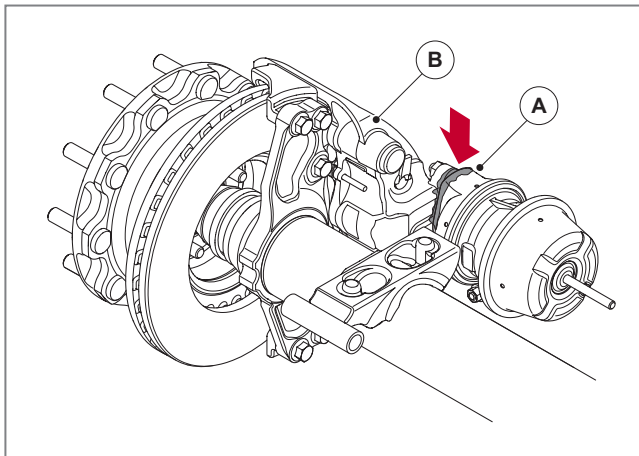

Fig. 23 - Mating surfaces of the brake chamber and brake calliper

This inspection procedure covers both types of brake chamber; normal (service) and spring brake (parking) chamber.

1. Read and follow „3.2 Initial procedure“ prior to inspecting the actuation interface.
2. Thoroughly clean around the mating surfaces of the brake chamber (A) and brake calliper (B) to ensure that dirt does not get into the mechanism area when removing the brake chamber, see ► Fig. 23.
3. Release the parking brake, see ► chapter 3.2.1.

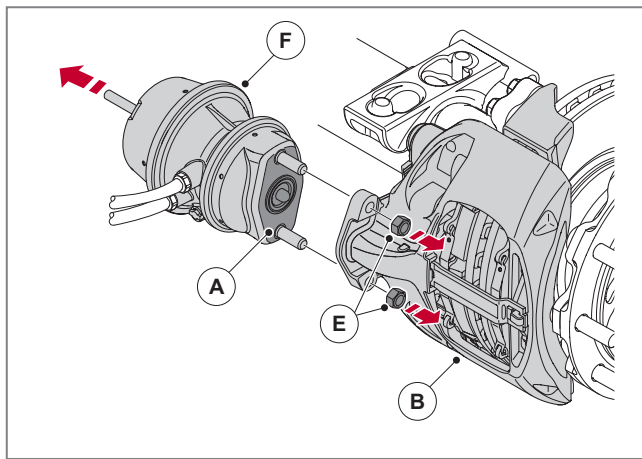

Fig. 24 - Removing the brake chamber components

4. If applicable, ensure that the spring brake chamber see ► Fig. 24 (F) is fully disengaged and mechanically secured in this position.
5. Ensure that the brake chamber is depressurised.
6. Remove the two nuts (E) holding the brake chamber. Remove the brake chamber (A/F) from the brake calliper (B), see ► Fig. 24.

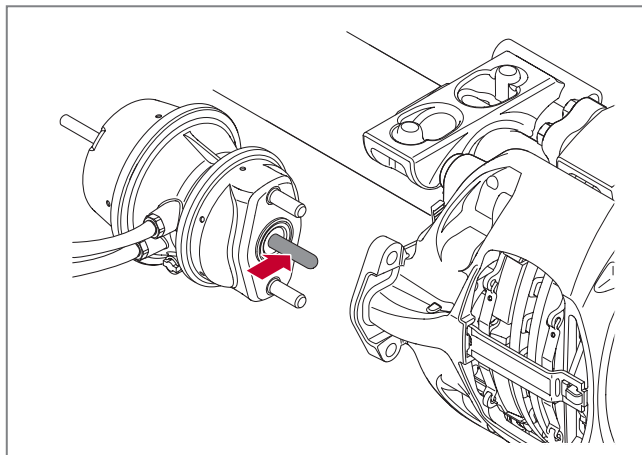
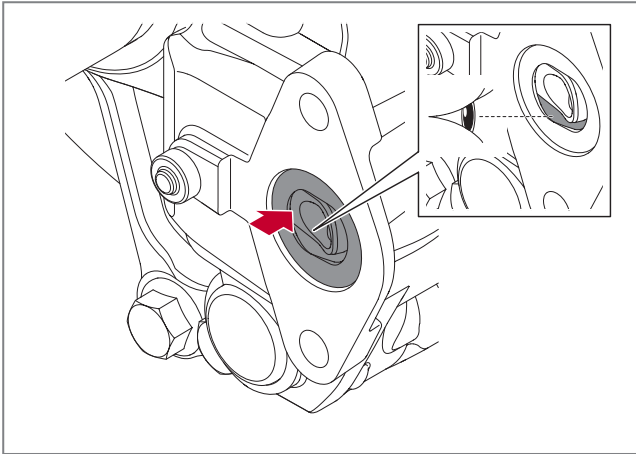

Fig. 25 - Piston rod

7. With the brake chamber removed and secured, the brake chamber piston rod should protrude approx. 15 mm in its rest position, see ► Fig. 25.
8. With the service brake activated, the brake chamber actuation rod should protrude approx. 72 mm - 80 mm (depending on the brake chamber type).
9. In addition, check that the actuation rod extends perpendicular to the external seal flange.



**Fig. 26** - Brake chamber aperture

10. Check through the aperture in the brake chamber attachment flange for moisture/corrosion, see ► *Fig. 26*. It is essential to look inside the aperture and not just on the surface. In the event of corrosion, further inspection is necessary. In the event that water has ingressed causing internal corrosion/damages to the mechanism, replace the brake calliper to avoid malfunction. For requisite measures, see "Replacing the brake calliper".

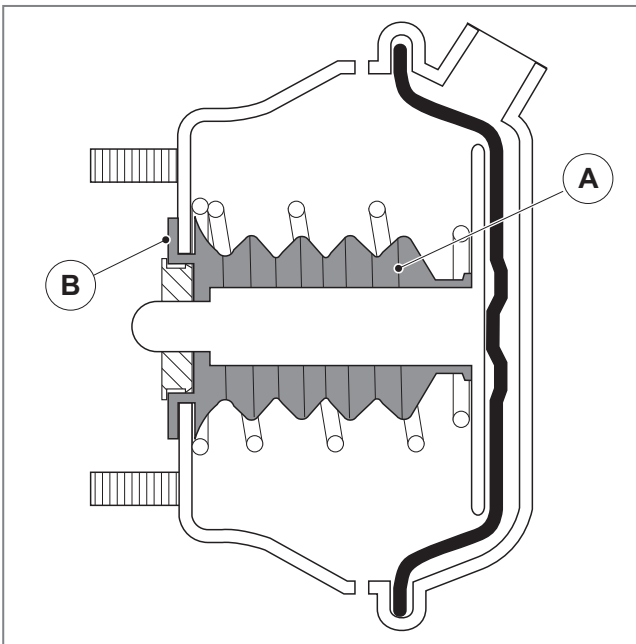

**Fig. 27** - Internal view of the brake chamber

11. On the brake chamber, there must be an internal bellows (A) on the piston rod, see ► *Fig. 27*.
12. Check that the bellows are complete and not damaged by inspecting around and down the piston rod shaft. Check for signs of water or corrosion. These may be a sign that the bellows are damaged.
13. Check that the external seal flange (B) is correctly seated, intact and undamaged.

14. Once the inspection is completed satisfactorily, conclude by reading and following chapter „5.3.3 *Installing the brake chamber*“ and „5.3.4 *Final procedure*“.

#### 4.3.9 Checking the guide pin bellows



#### Danger!

Wear respiratory protection in order to avoid inhaling particles which can be hazardous to health! Brake pad wear produces dust which can cause lung damage!



#### Caution!

- Take care when using chemicals and/or cleaning tools (e.g. knives, brushes, etc.). This to avoid damage or displacement of hoses, seals and other components.
- Use a vacuum cleaner to clean the surfaces. Do not use compressed-air.

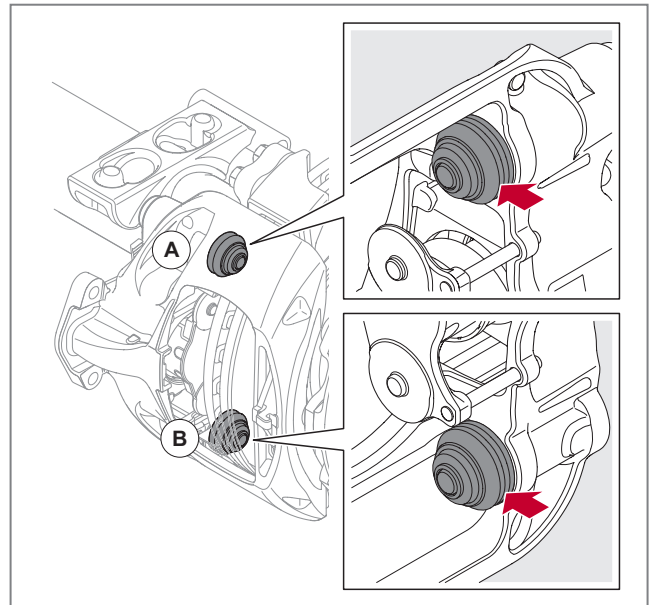

**Fig. 28** - Inspecting the guide pin bellows

Read and follow „3.2 *Initial procedure*“ prior to inspecting the guide pin bellows.

15. Inspect the fixed bearing guide pin bellows (A) and the floating bearing guide bolt bellows (B), see ► *Fig. 28*. Inspect all around the bellows for signs of damage as a result of debris, stones or overheating.
16. If the bellows are damaged then they must be replaced. For instructions on how to replace the bellows, read and follow chapter „4.3.11 *Checking the slide function*“.

17. Once the inspection is completed satisfactorily, conclude by reading and following chapter „5.3.3 *Installing the brake chamber*“ and „5.3.4 *Final procedure*“.

#### 4.3.10 Checking the thrust plate bellows



#### Danger!

Wear respiratory protection in order to avoid inhaling particles which can be hazardous to health! Brake pad wear produces dust which can cause lung damage!



#### Caution!

- Take care when using chemicals and/or cleaning tools (e.g. knives, brushes, etc.). This to avoid damage or displacement of hoses, seals and other components.
- Use a vacuum cleaner to clean the surfaces. Do not use compressed-air.
- Never use an impact wrench or similar to rotate the reset shaft. This may damage the disc brake mechanism! The maximum torque is 20 Nm.



#### Note:

Do not over adjust/extend the thrust plate whilst carrying out the inspection. Over adjustment/extension may cause the thrust plate to disengage from the adjustment screw and if done unintentionally may cause damage to the thrust plate bellows! The min. distance between the brake calliper and thrust plate is 60 mm.

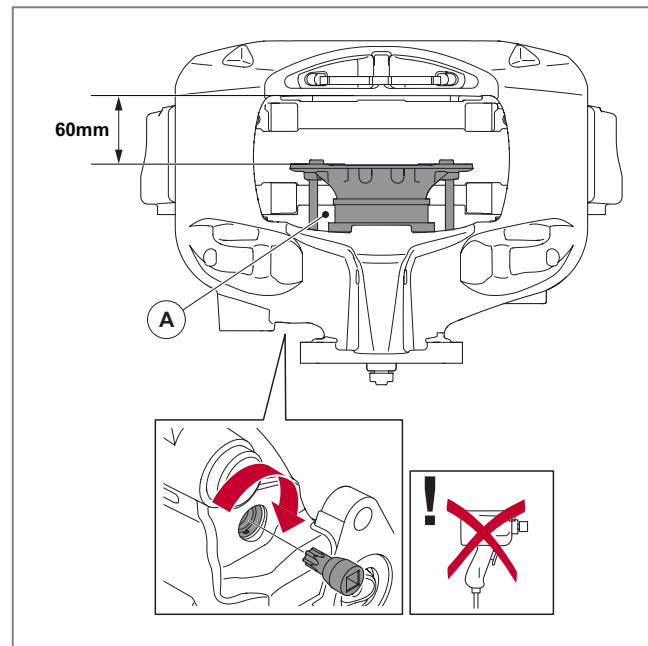

Fig. 29 - Max. unscrewing for inspecting the thrust plate bellows

1. Read and follow „3.2 *Initial procedure*“ and „5.2.2 *Removing the brake pads*“ prior to inspecting the thrust plate bellows.
2. Use the Torx 55 socket to manually rotate the reset shaft clockwise. This unscrews the thrust plate (A) from the adjustment screw so that the bellows can be inspected. Stop when the distance between the inner pad face of the thrust plate and outer pad face of the brake calliper is 60 mm, see ► Fig. 29.

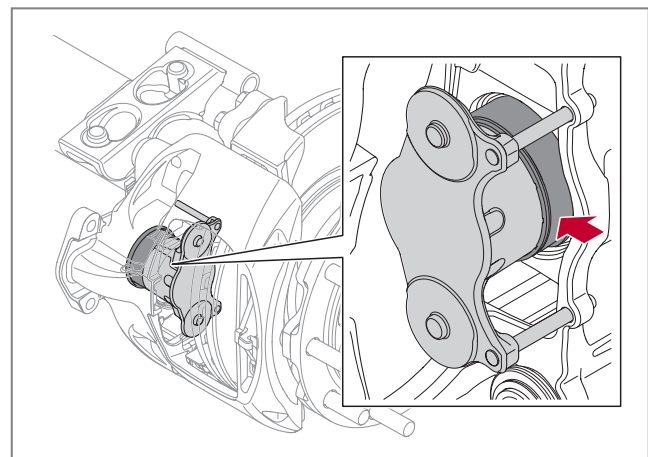

Fig. 30 - Inspect the adjustment screw bellows

3. Inspecting the adjustment screw bellows, see ► Fig. 30. Inspect all around the bellows for signs of damage as a result of debris, stones or overheating.
4. If the bellows are damaged then they must be replaced. For instructions on how to replace the bellows, read and follow chapter „5.4 *Replacing the adjustment screw bellows*“.



5. If OK then manually retract the thrust plate by rotating the reset shaft anti-clockwise with the Torx 55. Continue rotating until the position required to refit the brake pads is reached.
6. Once the inspection is completed satisfactorily, conclude by reading and following chapter „5.3.3 Installing the brake chamber“ and „5.3.4 Final procedure“.

#### 4.3.11 Checking the slide function



#### Danger!

Wear respiratory protection in order to avoid inhaling particles which can be hazardous to health! Brake pad wear produces dust which can cause lung damage!



#### Caution!

- Take care when using chemicals and/or cleaning tools (e.g. knives, brushes, etc.). This to avoid damage or displacement of hoses, seals and other components.
- Use a vacuum cleaner to clean the surfaces. Do not use compressed-air.

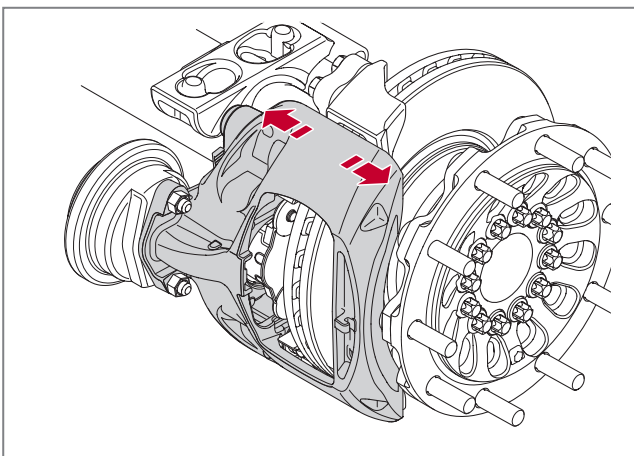

**Fig. 31** - Free mobility of the brake calliper, must be able to slide freely on the guide pin.

1. Read and follow „3.2 Initial procedure“ and „5.2.2 Removing the brake pads“ prior to inspecting the slide function.
2. Once the brake pads are removed, move the brake calliper by hand back and forth to check its movement, see ► Fig. 31.
3. If the movement is restricted in any way, the cause must be determined, see chapter „8.2 Inspection intervals“.

4. If the fault finding concludes that the slide function needs to be replaced, follow chapter „5.5 Replacing the slide function assembly“.
5. Once the inspection is completed satisfactorily, conclude by reading and following chapter „5.2.3 Installing the brake pads“ and „5.2.4 Final procedure“.



#### Note:

Restriction of the slide function can lead to operational impairment, e.g. hot brakes and uneven brake pad wear.

#### 4.3.12 Measuring the bearing clearance

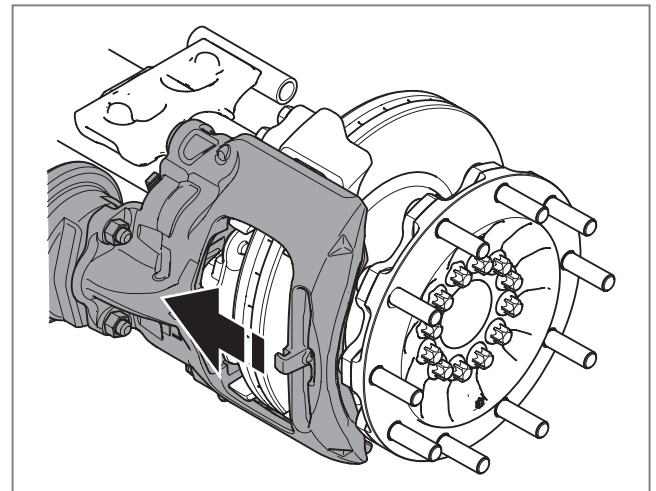

**Fig. 32** - Inside position of the brake calliper

1. Move the brake calliper by hand as far as possible in the direction of the arrow, see ► Fig. 32.

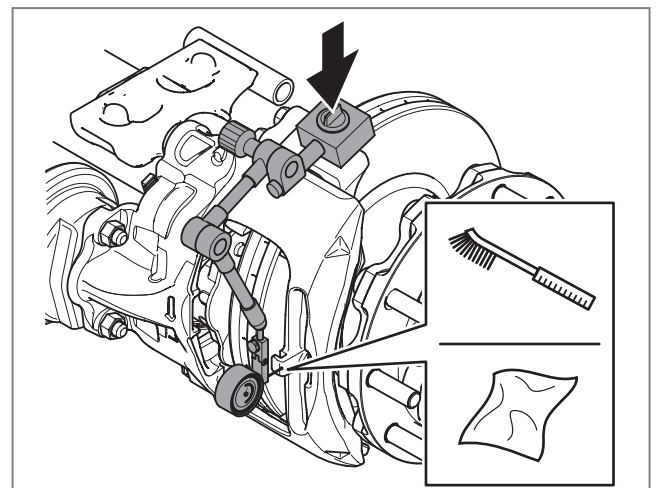

**Fig. 33** - Dial gauge on the brake calliper

2. Clean the measuring point and place the dial gauge on the support (arrow).

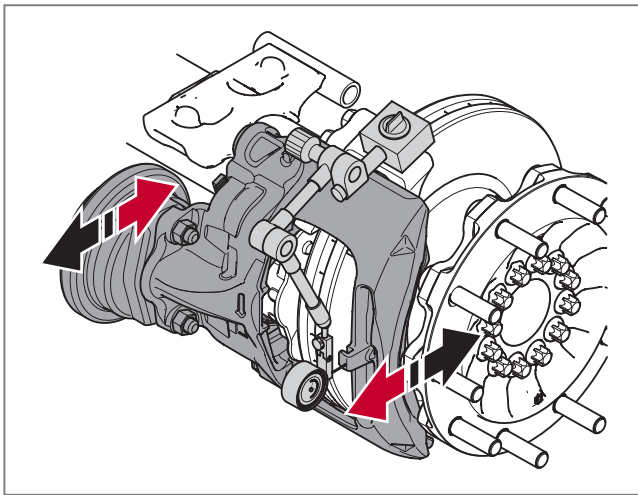

Fig. 34 - Measuring the brake calliper clearance

3. Tilt the brake calliper in the direction of the black arrows, see ► Fig. 34.
4. Set the dial gauge to zero.
5. Now tilt the brake calliper in the direction of the red arrows and read the clearance from the dial gauge, see ► Fig. 34.

### Measurement specification:

The bearing bushing must be replaced if the clearance exceeds 2 mm. See chapter „5.5 Replacing the slide function assembly“, see ► Fig. 35 and see ► Fig. 36.

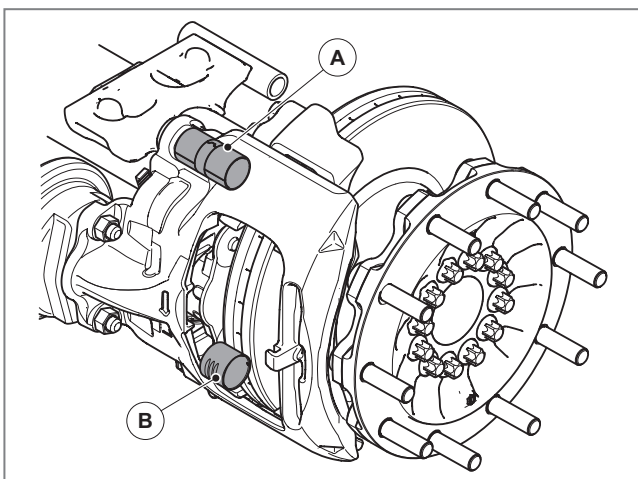

Fig. 35 - Brake calliper bearing

The floating bearing consists of a soft composite. If a metallic sound is produced by the floating bearing, it must be replaced.

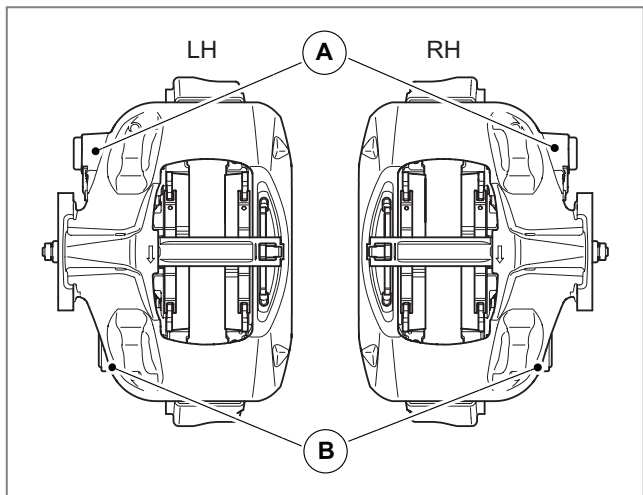

Fig. 36 - Fixed bearing (A) and floating bearing (B)

A = fixed bearing

B = floating bearing

## 5 Replacement procedure

### 5.1 General information

The objective of this chapter is to give instruction and guidance on how the disc brake and/or its components should be replaced. The replacement procedures in this chapter require the wheel to be removed to enable the replacement work to be carried out.

### 5.2 Replacing the brake pads

#### 5.2.1 Initial procedure

Read and follow chapter „3.2 Initial procedure“ prior to removing the brake pads.

#### 5.2.2 Removing the brake pads



#### Danger!

Wear respiratory protection in order to avoid inhaling particles which can be hazardous to health! Brake pad wear produces dust which can cause lung damage!

- Sudden release of tensioned springs can cause injury!
- Do not actuate the brake when replacing the brake pads!
- In addition, ensure that the compressed-air brake system is pressurised during the replacement procedure, (min. 6 bar)! If the pressure drops below 6 bar, the parking brake is actuated automatically.



#### Caution!

- Use a vacuum cleaner to clean the surfaces. Do not use compressed-air.
- Take care when using chemicals and/or cleaning tools (e.g. knives, brushes, etc.). This to avoid damage or displacement of hoses, seals and other components.

1. If necessary, remove dirt, dust and other possible debris.



#### Caution!

- Where indicated, use SAF-HOLLAND tools only.
- Never use an impact wrench or similar to rotate the reset shaft. Doing so could damage the internal components of the mechanism! The maximum torque is 20 Nm.



#### Note:

The thrust plate must be fully retracted to be able to fit new brake pads.

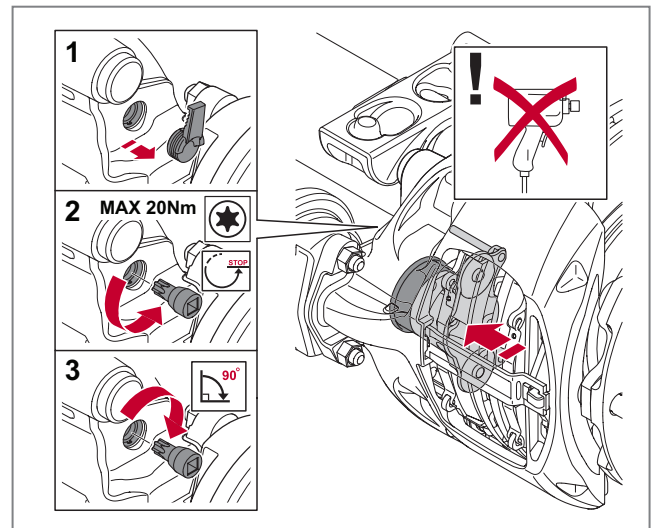

Fig. 37 - Resetting the thrust plate by reset shaft

2. Remove the reset shaft protective plug, see ► Fig. 37.
3. Use the Torx 55 socket to manually rotate the reset shaft anti-clockwise. This de-adjusts the brake so that the thrust plate fully retracts to its inner position. A clicking sound must be heard and felt when retracting. The inner thrust plate position must be distinct. The tightening torque must not exceed 20 Nm. The de-adjust position must not be maintained. In the de-adjust position, the adjustment function is overridden.



#### Caution!

Always ensure the pad retainer spring bracket is fully held down whilst levering out the pad retainer.

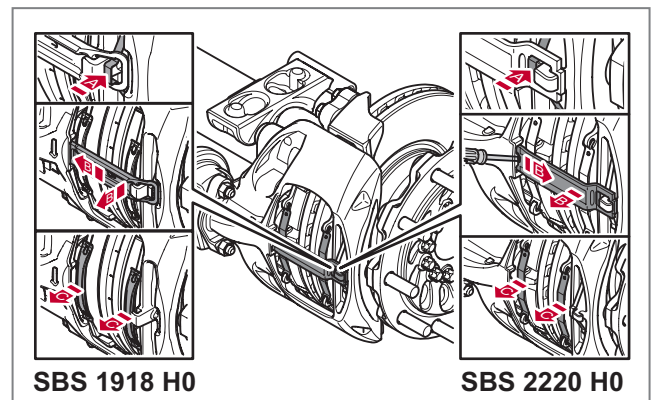

Fig. 38 - Removing the brake pad components

- Remove the pad retainer by first pushing and holding down the spring bracket (A), see ► Fig. 38. Whilst the spring bracket (A) is held down, slide out and remove the pad retainer (B). A tool can be used to help slide out the pad retainer if unable to do so by hand. Continue to remove the two pad springs (C).

**Caution!**

Always remove the outer brake pad first! You cannot directly pull out the inner brake pad with the outer brake pad still in place as the inner brake pad is located to the thrust plate at two points.

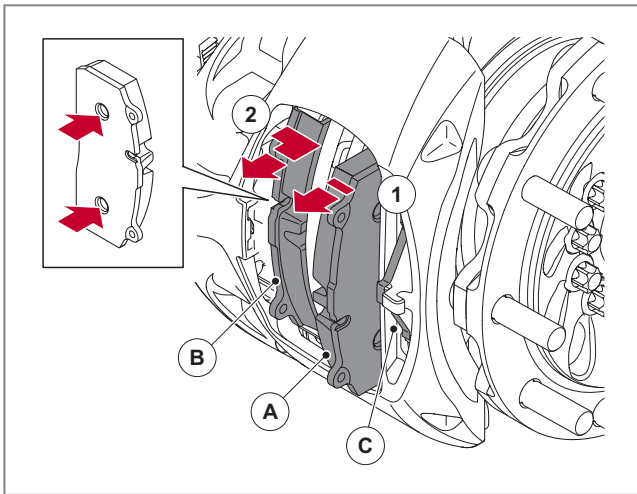

Fig. 39 - Removing the brake pads

- Remove the brake pads. Firstly remove the outer brake pad (A) followed by the inner brake pad (B), see ► Fig. 39.

The inner brake pad also locates at two points which mate to the thrust plate. Consequently, you cannot directly pull out the inner brake pad with the outer brake pad still in place. Once the outer brake pad is removed, the brake calliper can be slid across to allow for the inner brake pad to be removed.

- Remove the pad retainer spring bracket (C).

### 5.2.3 Installing the brake pads

**Caution!**

When replacing the brake pad, all components contained in the repair kit must be installed. The old components must be properly disposed of.

- Ensure that the brake is fully de-adjusted before fitting the new brake pads.
- Check that the contact surfaces on the carrier, brake calliper and thrust plate are free from dirt and corrosion. Clean the thrust plate as required.

**Caution!**

- The inner brake pad must always be installed first!
- Ensure that the friction material faces the brake disc!

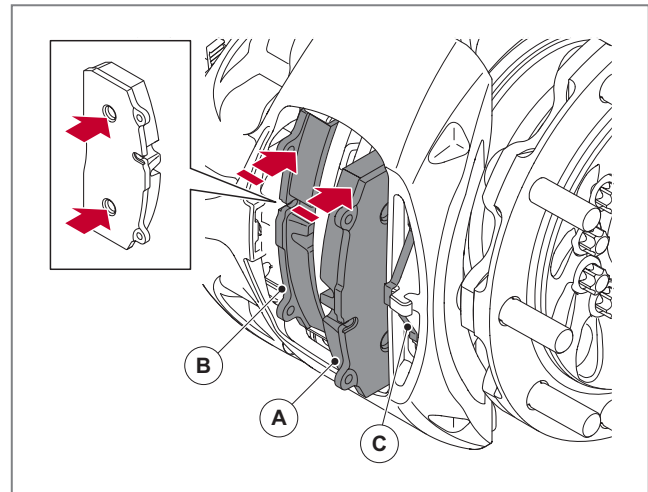

Fig. 40 - Installing the brake pads

- First install the inner brake pad (B) in the carrier. Note that the inner brake pad locates onto the thrust plate at two points, see ► Fig. 40. Then fit the outer brake pad (A).
- Check that the contact surfaces on the pad retainer spring bracket are free from dirt and corrosion. Clean the pad retainer as required.
- Install a new spring bracket (C) on the brake calliper and ensure that it is seated correctly.

**Danger!**

When fitting, ensure that the pad retainer spring bracket is in its correct locking position.



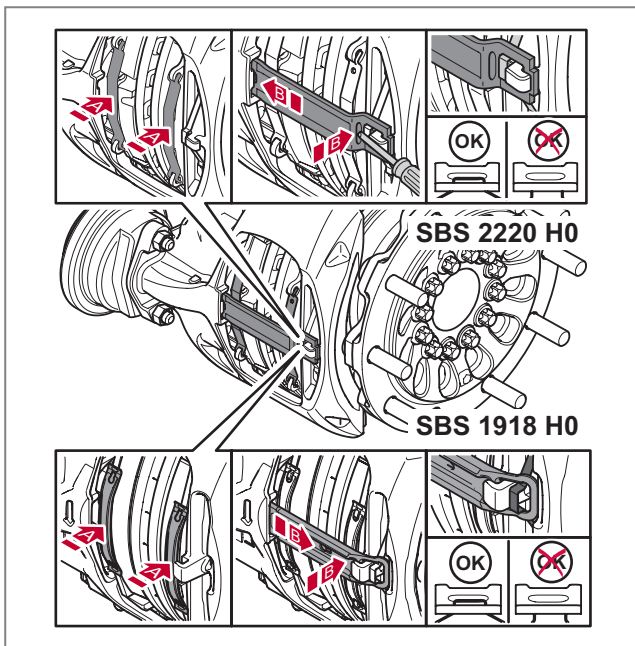

Fig. 41 - Install the brake pad components

- Fit the new pad springs (A) and the pad retainer (B). The pad retainer is secured by first locating it in the housing end in the brake calliper aperture. The pad springs are then compressed and the rectangular aperture of the pad retainer is placed over the brake calliper seal. The pad retainer is then slid under the brake calliper seal until the spring bracket engages in its locking position, see ► Fig. 41. If necessary, use a tool to help push the brake pad retainer into position.

### 5.2.4 Final procedure

To conclude this procedure, read and follow chapters:

- „3.3 Function test“, to ensure that the disc brake is working correctly.
- „3.4 Final procedure“

## 5.3 Replacing the brake chamber

### 5.3.1 Initial procedure

Read and follow chapter prior to removing the spring brake chambers.

### 5.3.2 Removing the brake chamber



#### Danger!

Wear respiratory protection in order to avoid inhaling particles which can be hazardous to health! Brake pad wear produces dust which can cause lung damage!

- If the disc brake is equipped with a parking brake function, ensure that the brake system is depressurised, that the spring brake chamber is fully disengaged and mechanically secured in this position. See the vehicle manufacturer's instructions.
- Pressure from lines and components must be released before they are opened!

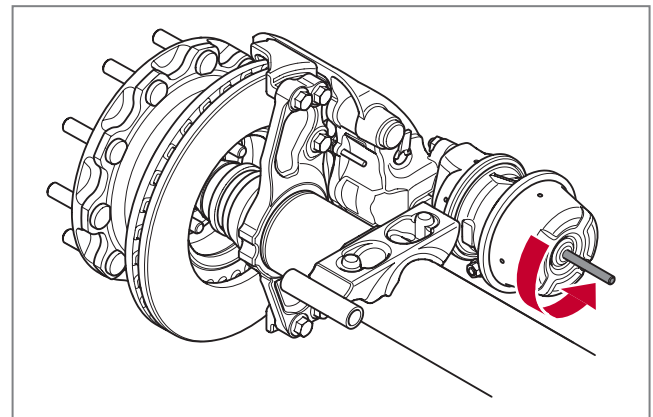

Fig. 42 - Securing with the extraction tool



#### Danger!

- Use a vacuum cleaner to clean the surfaces. Do not use compressed-air.
- Take care when using chemicals and/or cleaning tools (e.g. knives, brushes, etc.). This to avoid damage or displacement of hoses, seals and other components.

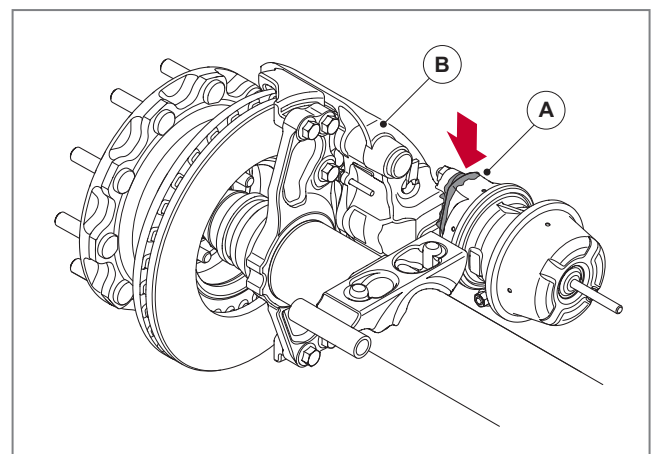

Fig. 43 - Mating surfaces of the brake chamber and brake calliper

Thoroughly clean around the mating surfaces of the brake chamber (A) and brake calliper (B) to ensure that dirt does not get into the mechanism area when removing the brake chamber, see ► Fig. 43.

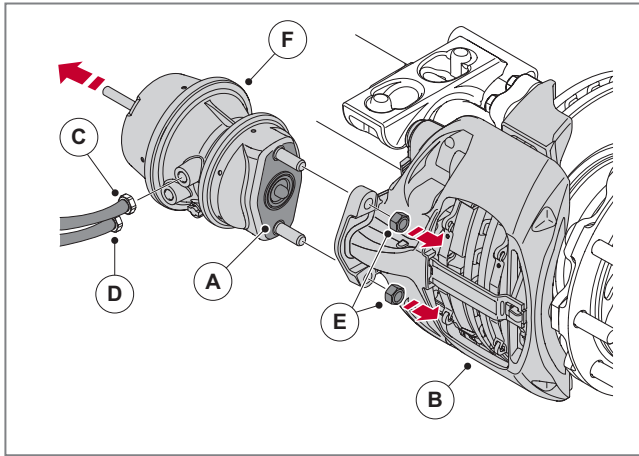

Fig. 44 - Removing the brake chamber components

3. If applicable, ensure that the spring brake chamber (F) is fully disengaged and mechanically secured in this position, see ► Fig. 44.
4. Ensure that the brake chamber (A) is depressurised.
5. Mark and remove the hose connections of the service brake (C) and, if applicable, the parking brake (D).
6. Remove the two nuts (E) holding the brake chamber. Remove the brake chamber (A) from the brake calliper (B).
7. Before removing the brake chamber, it is good practice and highly recommended to read and follow chapter „4.3.8 Checking the actuation interface“.

### 5.3.3 Installing the brake chamber

1. Check that the brake chamber being installed is the correct one for the application and vehicle. With the spring brake chamber installed, ensure that the springs of the parking brake have been locked in accordance with the vehicle manufacturer's instructions.
2. Before removing the brake chamber, it is good practice and highly recommended to read and follow chapter „4.3.8 Checking the actuation interface“.



#### Caution!

Take care when using chemicals and/or cleaning tools (e.g. knives, brushes, etc.). This to avoid damage or displacement of hoses, seals and other components.

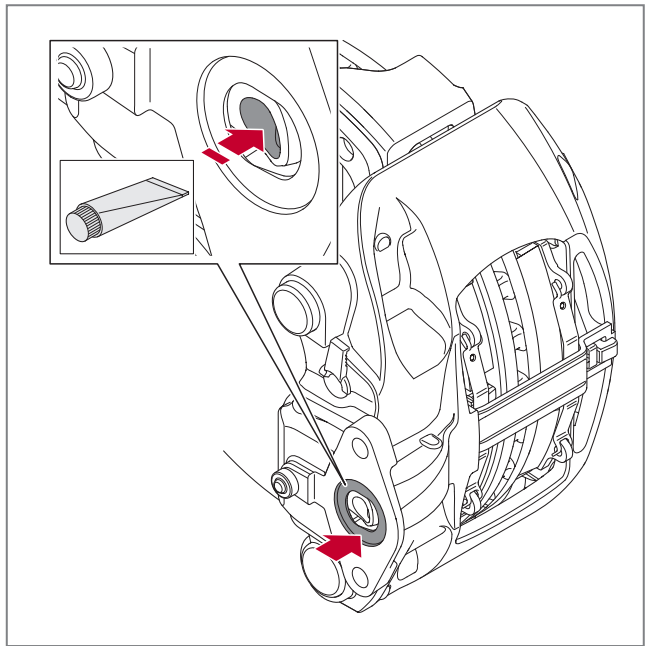

Fig. 45 - Inspection before fitting the brake chamber

3. Check that the mating surface of the chamber with the brake calliper housing and the mating surface on the brake calliper housing is free from dirt, moisture and corrosion, see ► Fig. 45. Ensure that the brake chamber seal is in the correct position and not damaged.
4. Put a knob of general purpose grease in the ball cup of the brake chamber lever. Do not overfill the cup or let grease fall inside the brake.

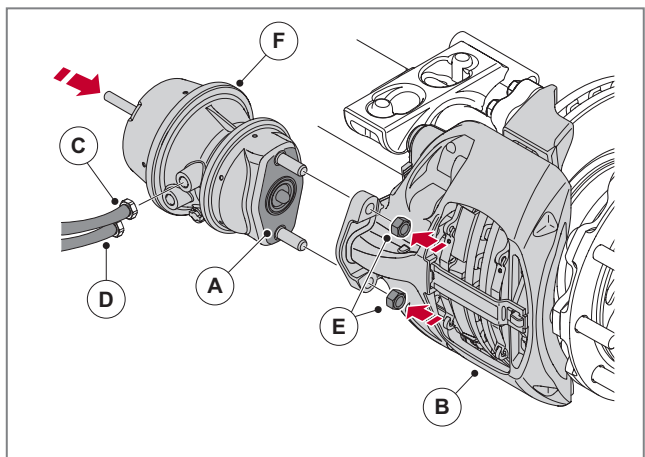

Fig. 46 - Installing the brake chamber components

5. Affix the new brake chamber (A) to the brake calliper (B) using the nuts (E), see ► Fig. 46. Screw on the nuts before tightening in order to ensure parallel seating of the brake chamber. The brake chamber nuts must be tightened to 180 - 210 Nm.



#### Caution!

Do not mix up the hoses!

- Secure the service brake hoses (C) and, if applicable, the parking brake hoses (D). When fitting the hoses, ensure that the connections (C) and (D) are correctly assigned, see ► Fig. 46.

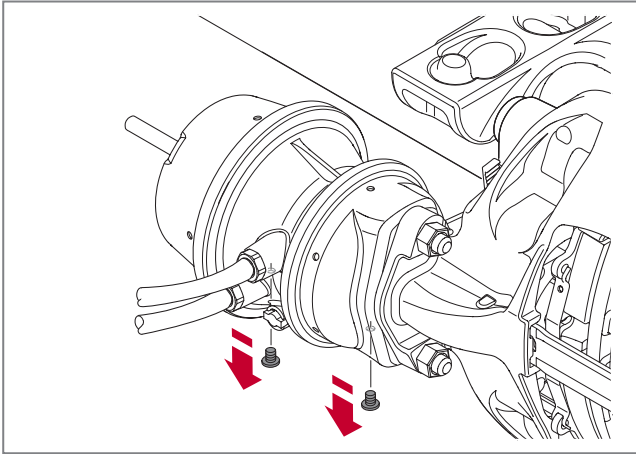

Fig. 47 - Removing the vent plugs

- Remove the downwards facing vent plugs from the brake chamber housing, see ► Fig. 47. If applicable, repeat this procedure for the spring brake chamber.



**Caution!**

Apply air to the parking brake. Ensure that there is sufficient pressure in the system (min. 6 bar).

- If applicable, release the parking brake and disengage the spring brake chamber relief mechanism so that the spring is released. The min. pressure in the compressed-air system is 6 bar.
- With the service brake engaged and, if applicable, with the parking brake released, check the brake chamber, hoses and connections for leaks and damage.

**5.3.4 Final procedure**

To conclude this procedure, read and follow chapters:

- „3.3 Function test“, to ensure that the disc brake is working correctly.
- „3.4 Final procedure“

**5.4 Replacing the adjustment screw bellows**

**5.4.1 Initial procedure**

Read and follow the chapters below prior to removing the adjustment screw bellows.

- „3.2 Initial procedure“
- „5.2.2 Removing the brake pads“
- „5.3.2 Removing the brake chamber“

4. „5.7.2 Removing the disc brake“

**5.4.2 Removing the adjustment screw bellows**

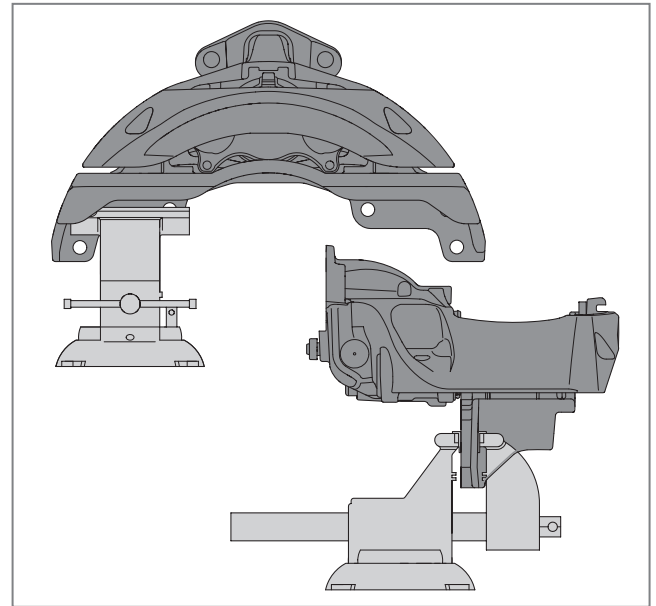

Fig. 48 - Clamping device for replacing the adjustment screw bellows

- Fasten the disc brake securely in a vice with soft jaws, see ► Fig. 48. Ensure that the jaws of the vice do not damage the disc brake.

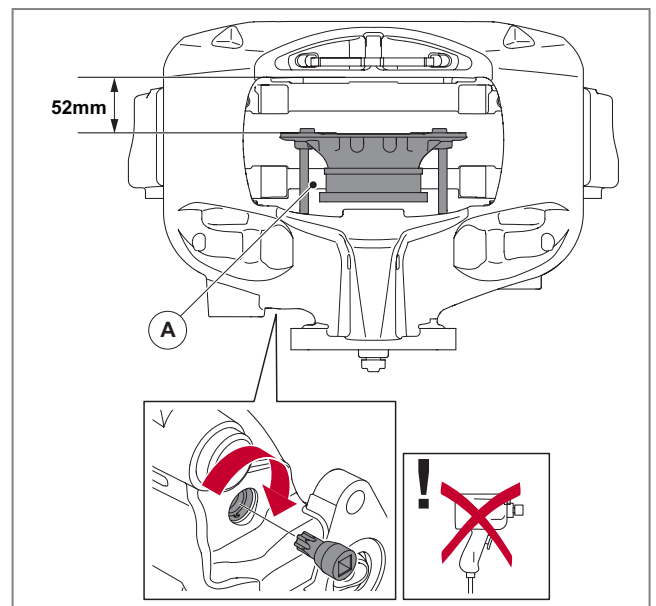

Fig. 49 - Releasing the thrust plate

- Use the Torx 55 socket to manually rotate the reset shaft clockwise in order to release the thrust plate (A). Continue extracting until the thrust plate unscrews fully and becomes detached from the adjustment screw, see ► Fig. 49. The point at which the thrust plate becomes detached is when the gap between the thrust plate inner pad face and the brake calliper outer pad face becomes smaller than 52 mm. Be careful when removing the thrust plate not to damage its internal thread or the external thread of the adjustment screw.
- Once the thrust plate becomes detached from the adjustment screw, pull off the adjustment screw bellows from the thrust plate and brake calliper by hand. Do not use any tools for this removal because damaging the mating surfaces could cause water penetration leakage or seal corrosion upon re-assembly!

#### 5.4.3 Cleaning



#### Caution!

- Use a vacuum cleaner to clean the surfaces. Do not use compressed-air.
- Take care when using chemicals and/or cleaning tools (e.g. knives, brushes, etc.). This to avoid damage or displacement of hoses, seals and other components.
- Ensure that dirt and impurities do not enter the opening for the adjustment screw!

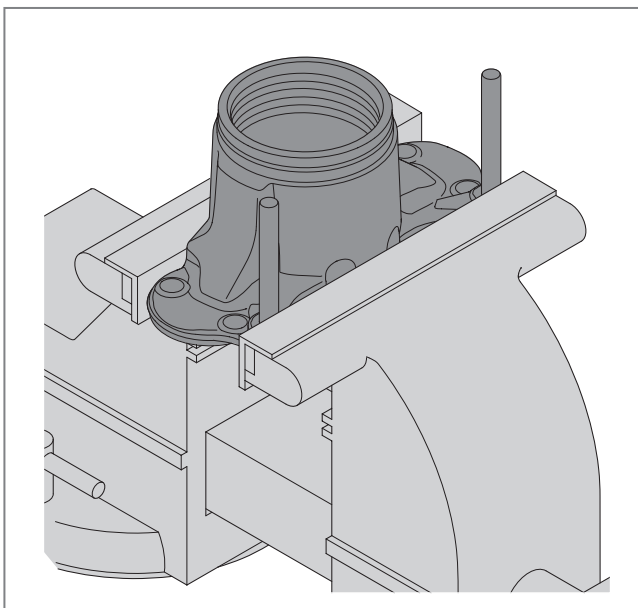

Fig. 50 - Clamping device for the thrust plate

Clean the thrust plate, the adjustment screw and the adjustment screw bellows mating surfaces in the brake calliper. Ensure that the components are free from dirt, dust, debris, moisture and corrosion.

- Fasten the thrust plate securely in a vice with soft jaws, see ► Fig. 50. Do not over tighten or damage the thrust plate whilst clamping!
- Clean the internal threaded surfaces of the thrust plate.
- Ensure that the contact surfaces between the thrust plate and the bellows are clean and free from dirt, moisture and corrosion.



#### Caution!

Where indicated, use SAF special tools only!

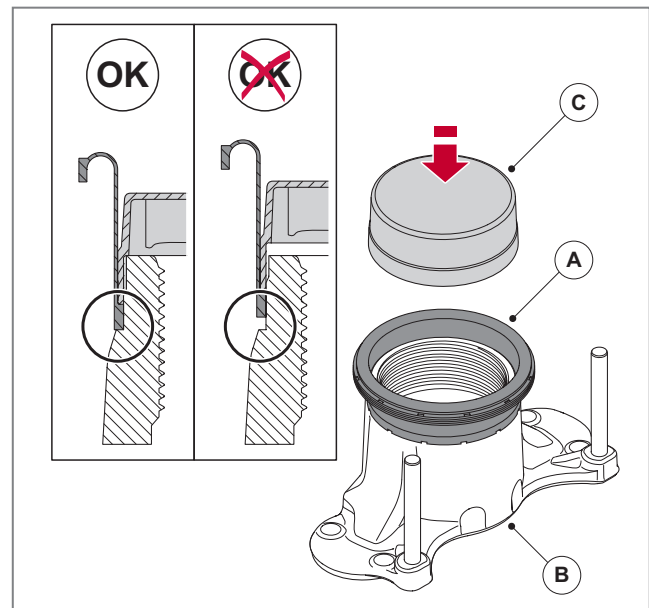

Fig. 51 - Fixing the thrust plate bellows

- Using SAF special tool P/N 4 434 3886 0 (C), press the adjustment screw bellows (A) into position on the thrust plate (B), see ► Fig. 51. Check that the bellows are correctly seated in position on the thrust plate.
- Clean the external threaded surfaces of the adjustment screw. Ensure that the components are free from dirt, dust, debris, moisture and corrosion.
- Apply the grease supplied with the spare parts kit to the internal thread off the thrust plate and the external thread of the adjustment screw.
- Remove the thrust plate from the vice.



#### Caution!

Do not damage the thread of the thrust plate or adjustment screw!



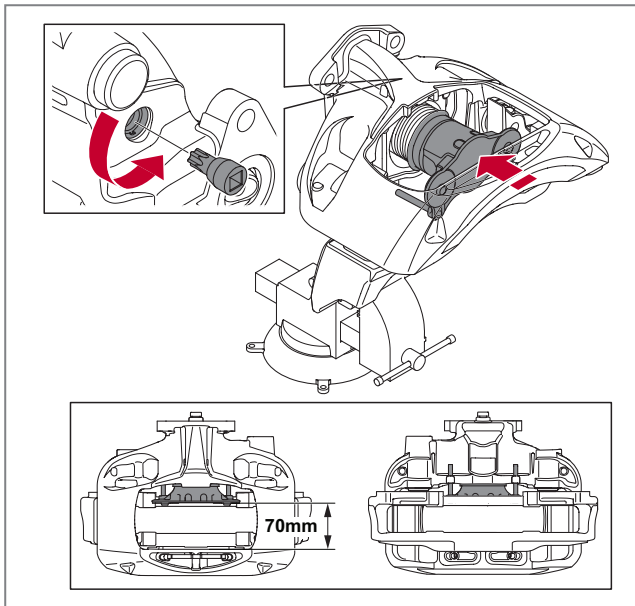

**Fig. 52** - Inserting the thrust plate

8. Hold the thrust plate in position by hand against the adjustment screw. Insert the Torx 55 socket into the reset shaft and rotate carefully anti-clockwise. Carefully engage the thrust plate thread into the thread of the adjustment screw. Ensure that the thread does not become damaged when rotating. If the thread becomes tight or locks, rotate the reset shaft clockwise to release the thrust plate, then try again. A clicking sound will be heard and felt when rotating the reset shaft anti-clockwise, see ► Fig. 52.
9. Once the threads are engaged, ensure that the thrust plate guide pins correctly locate in the brake calliper apertures.
10. Continue to retract the thrust plate until the distance between the thrust plate inner pad face and the brake calliper outer pad face is smaller than 70 mm, see ► Fig. 52.

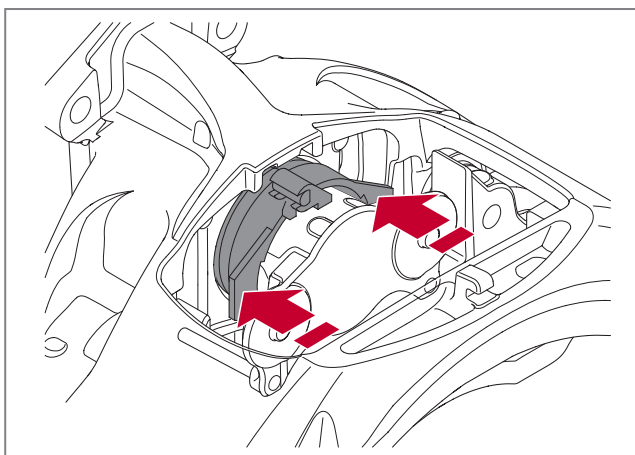

**Fig. 53** - Pressing in the thrust plate bellows

11. Assemble SAF special tools P/N 4 434 3887 00 and P/N 4 434 3888 00 and insert them into the brake calliper end of the adjustment screw bellows, see ► Fig. 53.
12. Firmly press on the special tool with equal and parallel force so that the adjustment screw bellows is pressed into position within the brake calliper.
13. The special tool can be removed, rotated and then reapplied to aid the equal and parallel seating.

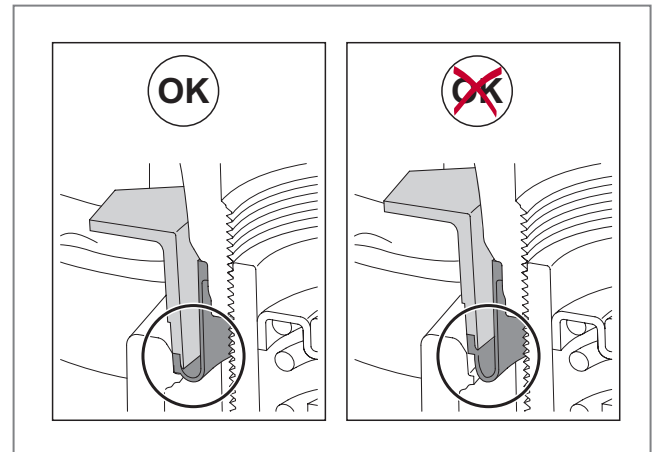

**Fig. 54** - Thrust plate bellows seated correctly/incorrectly

14. Remove the special tool. Check that the bellows are correctly seated in the brake calliper, see ► Fig. 54. Double check that the bellows are correctly positioned on the thrust plate, see ► Fig. 51. Failure to seat the bellows correctly will compromise the service life of the brake!
15. Retract the thrust plate fully to its inner position by manually rotating the reset shaft anti-clockwise. A clicking sound must be heard and felt when retracting. The inner thrust plate position must be distinct. The tightening torque must not exceed 20 Nm.



**Danger!**

The de-adjust position must not be maintained. In the de-adjust position, the adjustment function is overridden.

**5.4.4 Final procedure**

To conclude this procedure, read and follow chapters:

1. „5.7.3 Installing the disc brake“
2. „5.2.3 Installing the brake pads“
3. „5.3.3 Installing the brake chamber“
4. „3.3 Function test“, to ensure that the disc brake is working correctly.
5. „3.4 Final procedure“

## 5.5 Replacing the slide function assembly

### 5.5.1 Initial procedure

Read and follow the chapters below prior to removing the slide function assembly.

1. „3.2 Initial procedure“
2. „5.2.2 Removing the brake pads“
3. „5.3.2 Removing the brake chamber“
4. „5.7.2 Removing the disc brake“

### 5.5.2 Removing the slide function assembly



#### Caution!

Where indicated, use an SAF special tool only.

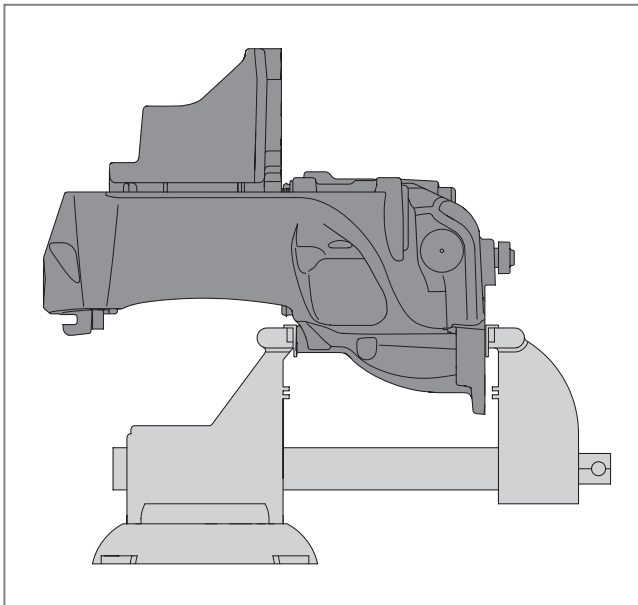

Fig. 55 - Clamping device for inserting the slide function assembly

1. Fasten the brake calliper securely in a vice with soft jaws, see ► Fig. 55. Ensure that the jaws of the vice do not damage the brake calliper.

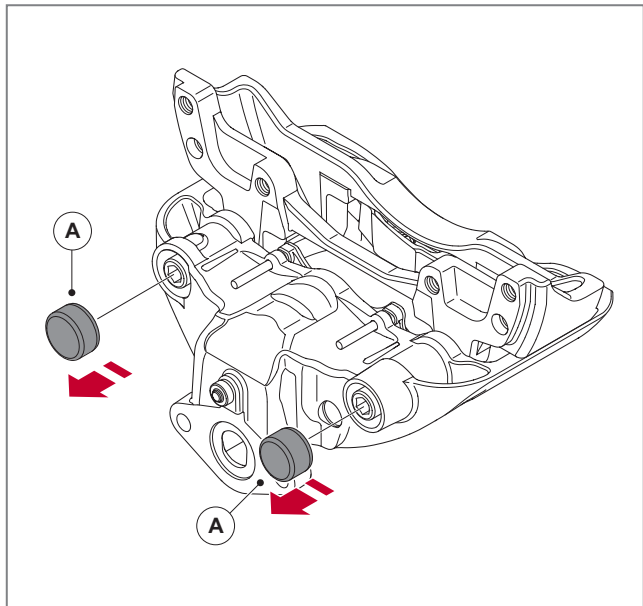

Fig. 56 - Removing the protective caps

2. Use a small hammer and chisel to remove the protective caps (A) from the fixed and floating bearing, see ► Fig. 56. The protective caps must not be re-used.

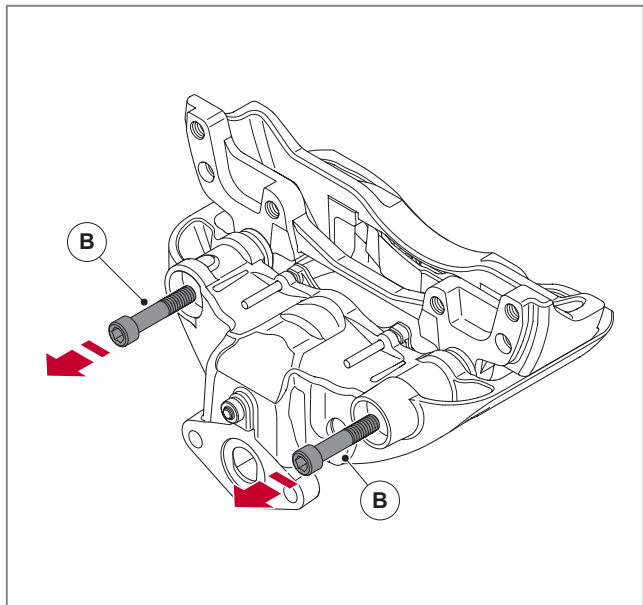
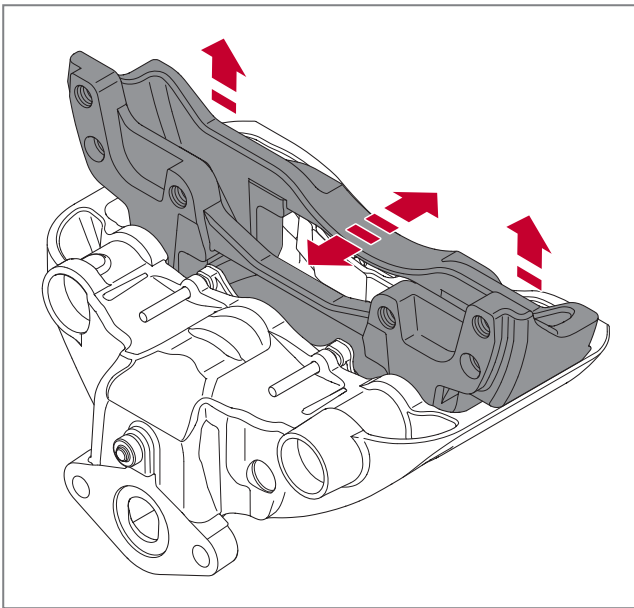

Fig. 57 - Removing the guide pin bolts

3. Using a long drive 14 mm Allen wrench, remove both bolts (B), see ► Fig. 57. The bolts must not be re-used.



**Fig. 58** - Removing the carrier

- Remove the carrier from the brake calliper by gently rocking the carrier to release it from the guide pins and bellows. Once released, press the guide pins back enough to be able to lift out the carrier, see ► *Fig. 58*.



**Caution!**

Where indicated, use an SAF special tool only.

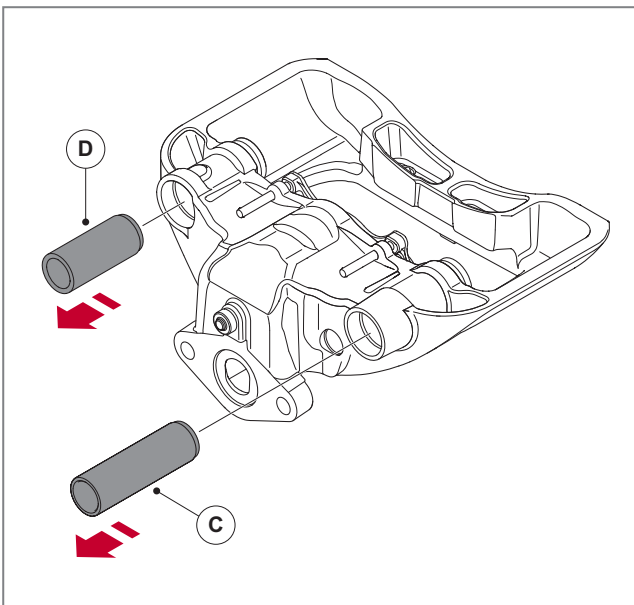

**Fig. 59** - Removing the guide pins

- By hand, push out the fixed bearing (C) and floating bearing (D), see ► *Fig. 59*.

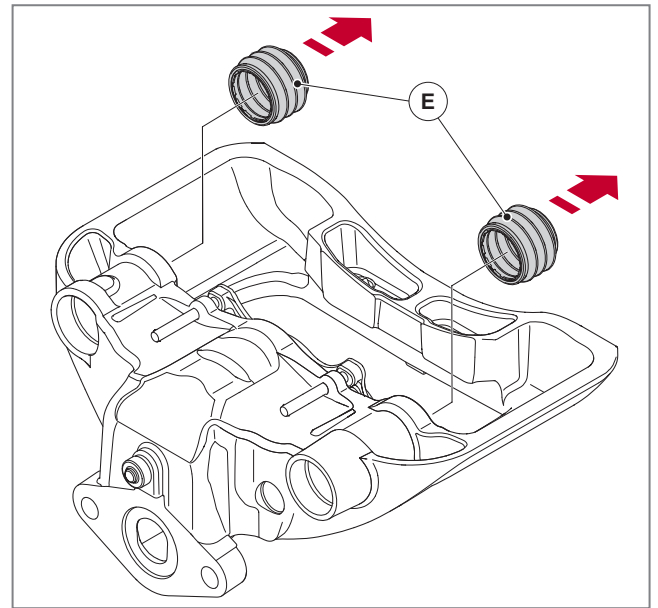

**Fig. 60** - Removing the bellows and guide pins

- Remove both guide pin bellows (E), see ► *Fig. 60*. If necessary, use a small screwdriver in order to lever them out. Be careful not to damage the guide pin bellows sealing surfaces if using a tool to lever out the bellows!

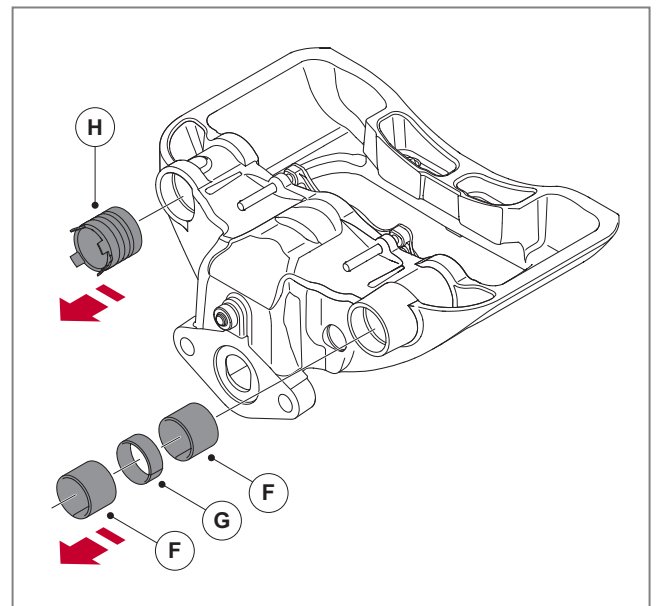

**Fig. 61** - Removing the slide bearings and side composite bushing

- Carefully follow the steps below, ► step 8 and ► step 9, to remove the two leading bearings (F) and the spacer (G) as well as the trailing composite bushing (H), see ► *Fig. 61*.

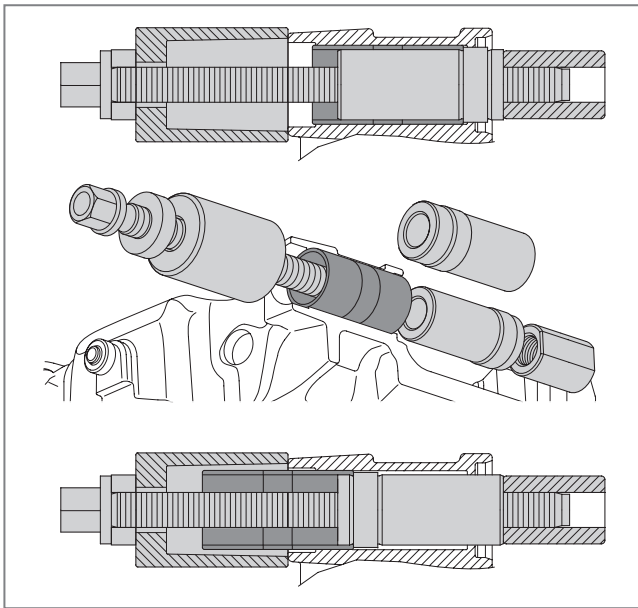

Fig. 62 - Remove the trailing slide bearing

8. To remove both bearings (F) and the spacer (G) on the leading side, assemble in sequence SAF special tools P/N 4 434 3884 00, P/N 4 434 3837, P/N 4 434 3848 0, P/N 4 434 3841 0; P/N 4 434 3890 0 and P/N 4 434 3889, as shown in □Fig. 55.
9. Once fitted correctly, rotate the threaded tool clockwise, which will pull out the two bearings (F) and the spacer (G). If necessary, rotate the mandrel P/N 4 434 3889 00 half way through the extraction process so that the nut P/N 4 434 3841 00 can be held.

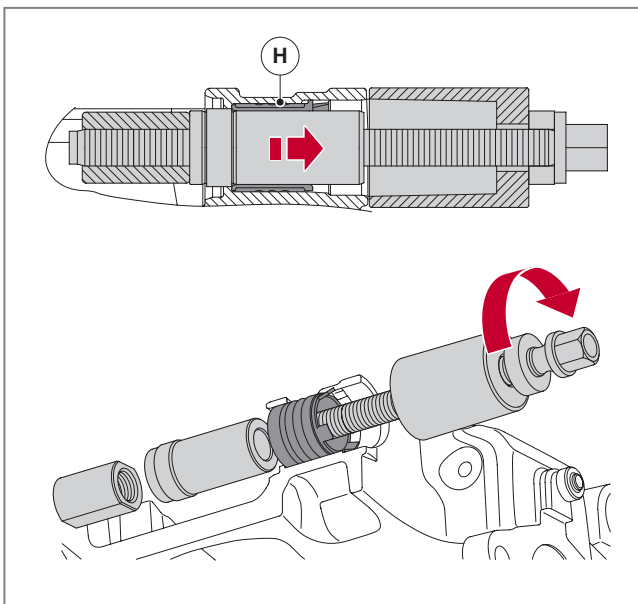

Fig. 63 - Removing the composite bushing

10. The composite bushing (H) on the floating bearing should be removed by hand.

11. If this is not possible, assemble in sequence SAF special tools P/N 4 434 3884 00, P/N 4 434 3837, P/N 4 434 3848 00, P/N 4 434 3841 00, P/N 4 434 3890 00 and P/N 4 434 3889, see ► Fig. 63.
12. Once fitted correctly, rotate the threaded tool clockwise, which will pull out the composite bushing.

### 5.5.3 Cleaning



#### Caution!

- Use a vacuum cleaner to clean the surfaces. Do not use compressed-air.
- Take care when using chemicals and/or cleaning tools (e.g. knives, brushes, etc.). This to avoid damage or displacement of hoses, seals and other components.

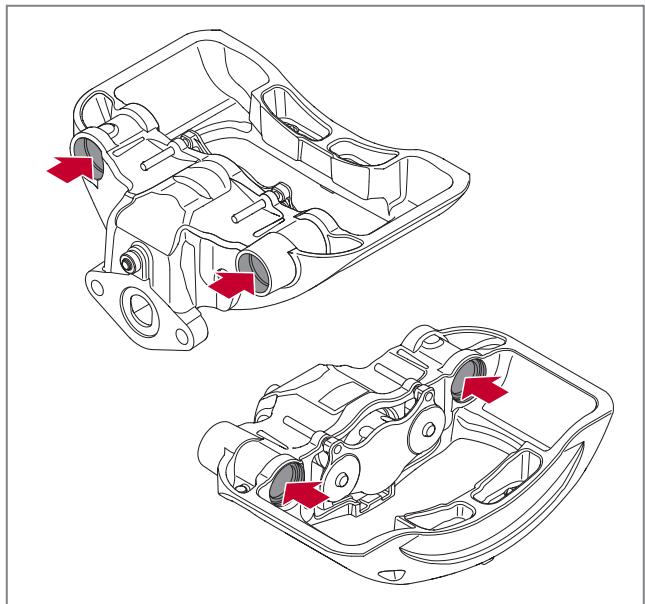

Fig. 64 - Cleaning the brake calliper bearing/bushing mating surfaces

1. Clean the bearing/bushing/bellows mating surfaces of the brake calliper to ensure that they are free from dirt, moisture, corrosion and damage, see ► Fig. 64.
2. If the sealing surfaces have lost their protective surface coating, apply/smear a small amount of general purpose grease over the whole area so that when components are refitted, the grease will provide corrosion protection.

### 5.5.4 Installing the slide function assembly



#### Caution!

Where indicated, use an SAF special tool only.

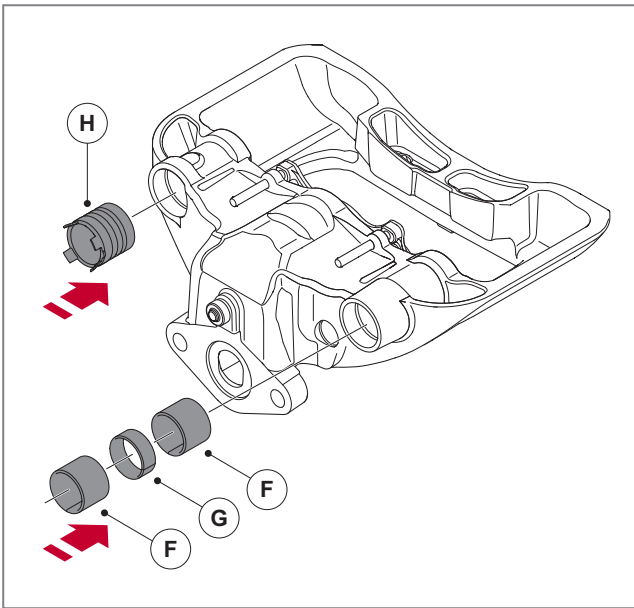

**Fig. 65** - Installing the leading slide bearing and trailing side bushing

1. Carefully follow the steps below, step 2 and step 3, to fit the two bearing bushings (F) of the fixed bearing and spacer (G) as well as the composite bushing (H) of the floating bearing, see ► Fig. 65.

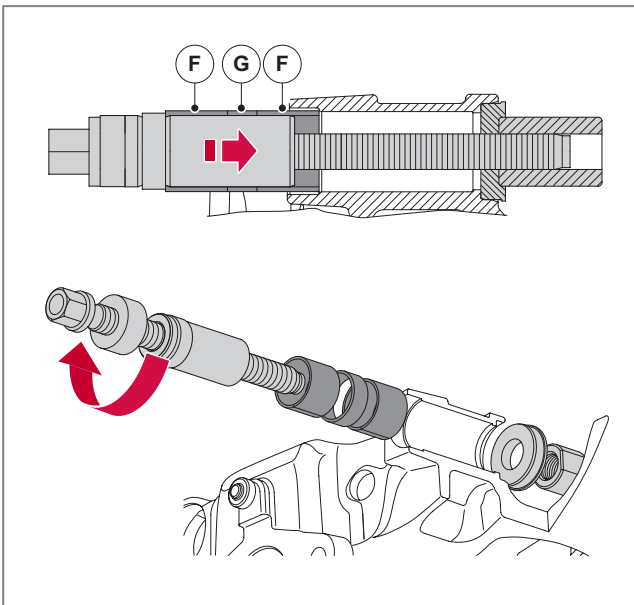

**Fig. 66** - Fitting the fixed bearing bushings

2. To install the two new bearing bushings (F) and the new spacer (G) on the leading side, assemble in sequence SAF special tools P/N 4 434 3837 00, P/N 4 434 3848 00, P/N 4 434 3841 00, P/N 4 434 3889 00 and P/N 4 434 3890 00, preloaded with the new components, see ► Fig. 66.
3. Once fitted correctly, rotate the threaded tool clockwise, which will pull into position the two bearing bushings (F) and the spacer (G).

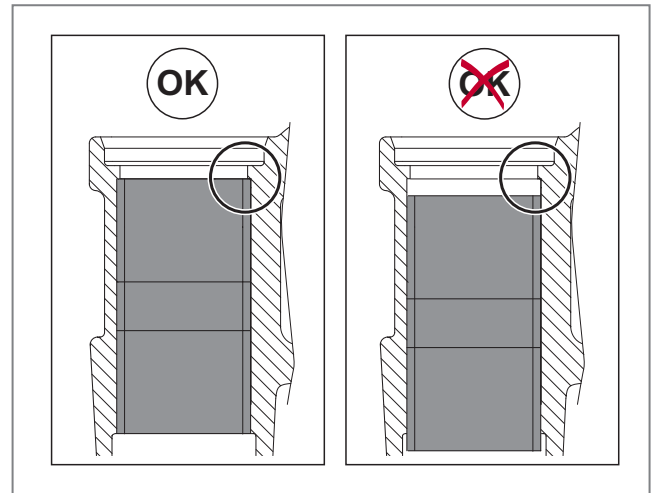

**Fig. 67** - Correct/incorrect installation of the fixed bearing bushings

4. Stop once the bearing bushings are seated in the correct position on the inside edge of the bearing locating surface, see ► Fig. 67. It is important that the bearing bushings are seated correctly. However, overtightening can cause damage.



**Caution!**

The floating bearing composite bushing must be aligned correctly when being installed into position by hand. If not correctly aligned, the slide function of the brake cannot be guaranteed.

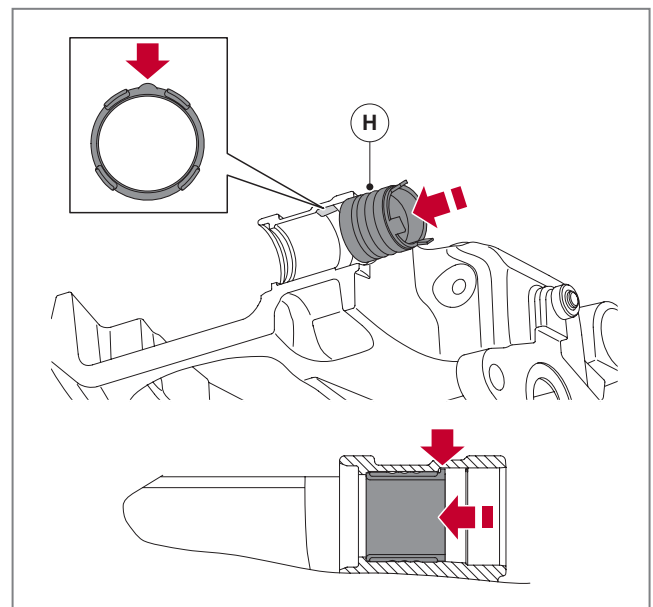

**Fig. 68** - Inserting the floating bearing composite bushing



5. To install the new composite bushing (H) on the floating bearing side, push the bushing into place as far as it will go. Ensure correct alignment in the brake calliper aperture, see ► Fig. 68. No tools or excessive forces are required for this fitting process. Nor should they be used! If used they may cause damage! If the bushing is not aligned correctly, the guide pin and protective cap may not fit!

**Caution!**

Once inserted, the guide pin bellows must seat correctly, i.e. as far as it will go in the intended groove.

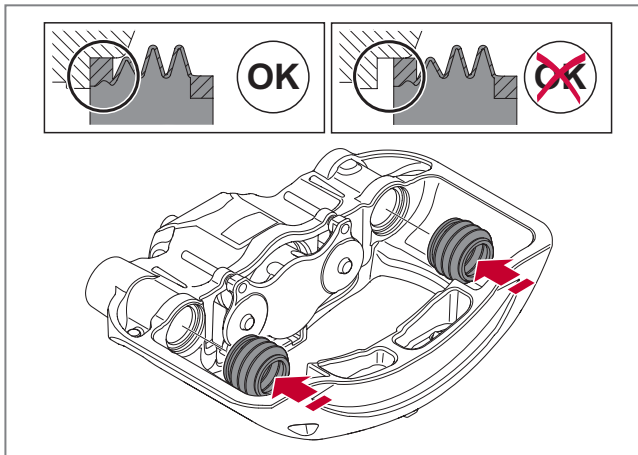

Fig. 69 - Installing the guide pin bellows

6. By hand, firmly push the two new guide pin bellows into the intended position, see ► Fig. 69. It is important to check that the bellows is correctly seated in the brake calliper, do so by looking inside the bellows. Failure to do so may compromise the slide function of the brake.

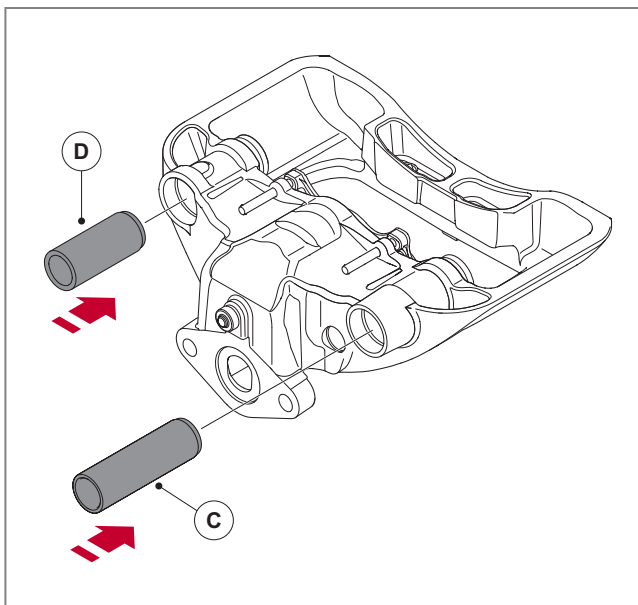

Fig. 70 - Inserting the guide pins

7. By hand, insert the fixed bearing guide bolt (C) into the bearing bushing and the floating bearing guide bolt (D) into the composite bushing, see ► Fig. 70. The longer guide pin (C) is inserted into the fixed bearing side. Note that one end of the guide pins has a machined groove. This side should be inserted first. No grease is required.
8. Check that the bellows location ring is fitted correctly and in one piece. By hand, locate the bellows onto the end of the guide pin. Ensure that the bellows and the bellows location ring are seated correctly on the guide pins. Failure to do so may compromise the slide function of the brake.
9. Clean the brake pad contact surfaces on the carrier, the brake calliper and the thrust plate. A wire brush can be used. Take care not to damage any of the bellows. Do not grind!

**Caution!**

Never refit used bolts!

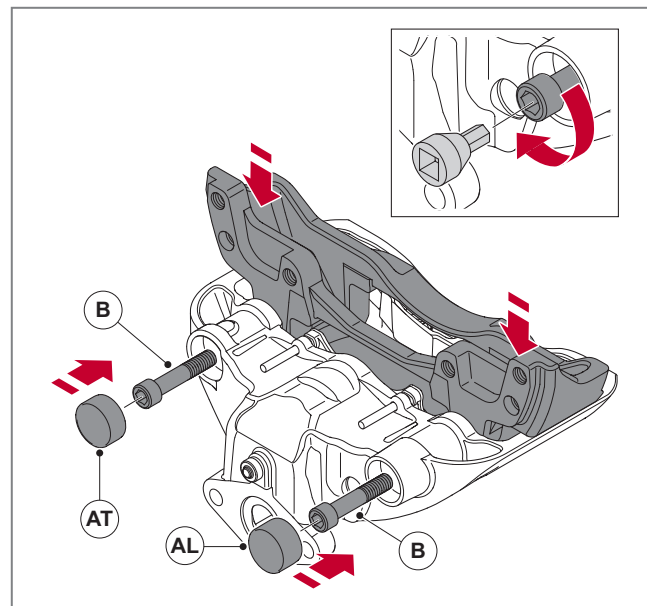

Fig. 71 - Refitting the carrier and its retaining bolts

10. Lift the carrier into position in the brake calliper, ensuring that the guide pins fitted with bellows do not interfere or obstruct. If necessary, push out the guide pins slightly by hand whilst lowering into the carrier. Hold the carrier in position whilst the two bolts are inserted and screwed in, see ► Fig. 71.
11. Use a 14 mm Allen wrench to screw in and tighten the bolts (B). The tightening torque is defined in chapter „6.2.2 SAF SBS 2220/SBS 1918 H0“.



### Caution!

The protective caps come in different sizes and, when fitted, must be seated correctly. The fixed bearing protective cap is smaller than the floating bearing protective cap. The fixed bearing protective cap must be in contact with the bearing and the floating bearing protective cap must be in contact with the brake calliper groove.

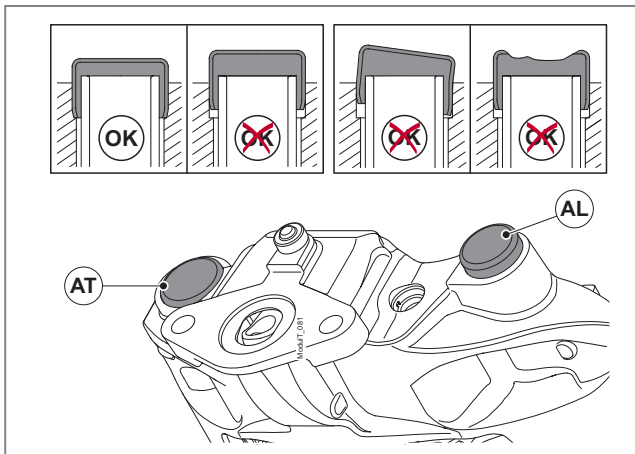

Fig. 72 - Correctly seating the protective caps

12. Carefully and squarely tap the protective caps (AT) and (AL) in place into using a soft headed mallet. Note that the caps are different sizes. The larger cap is fitted to the floating bearing side (AT) and the smaller cap is fitted to the fixed bearing side (AL). The fixed bearing protective cap (AL) is seated raised from the casting surface, whilst the floating bearing protective cap (AT) sits nearly flush, see ► Fig. 72.
13. Do not use excessive force or hit the caps at an angle. This may cause damage and impair the slide function of the brake.
14. Ensure that the protective caps are correctly seated as far as they will go, see ► Fig. 72.

#### 5.5.5 Final procedure

To conclude this procedure, read and follow chapters:

1. „5.7.3 Installing the disc brake“
2. „5.2.3 Installing the brake pads“
3. „5.3.3 Installing the brake chamber“
4. „3.3 Function test“, to ensure that the disc brake is working correctly.
5. „3.4 Final procedure“

## 5.6 Fully replacing the reset shaft

### 5.6.1 Initial procedure



### Caution!

Where indicated, use SAF special tools only!

Read and follow chapter „3.2 Initial procedure“ prior to fully removing the reset shaft.

### 5.6.2 Fully removing the reset shaft

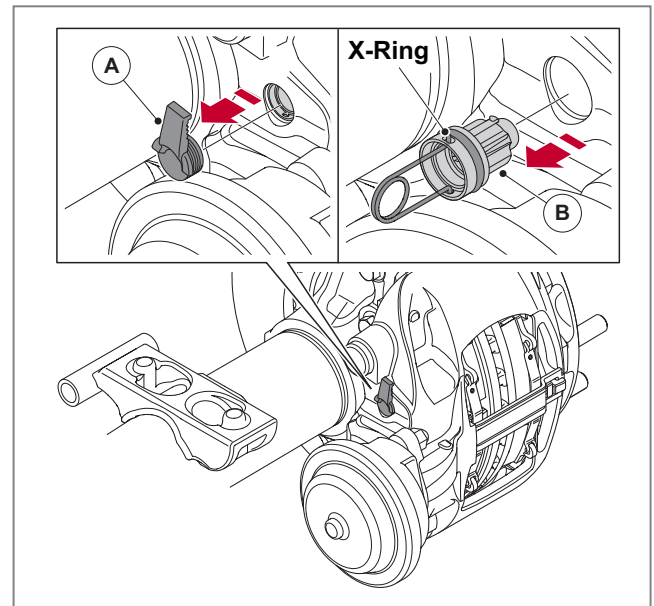

Fig. 73 - Removing the reset shaft

6. If necessary, remove dirt, dust and other possible debris from around the reset shaft area. Ensure that the area is clean prior to removing the reset shaft protective plug.
7. Remove the reset shaft protective plug (A).
8. Insert SAF special tool P/N 4 434 3885 00 and pull out the reset shaft (B) with complete x-ring, see ► Fig. 73. The x-ring must always be fitted to the reset shaft and never removed.

### 5.6.3 Fully installing the reset shaft

1. Clean the reset shaft locating surfaces in the brake calliper housing. Ensure that the areas are free from dirt, dust, debris, moisture and corrosion.
2. Insert the Torx 55 socket into the new reset shaft and insert this into the brake calliper. Whilst doing so, ensure that the x-ring is correctly in place. The reset shaft complete with x-ring is supplied ready lubricated. No additional grease or other lubrication is required.

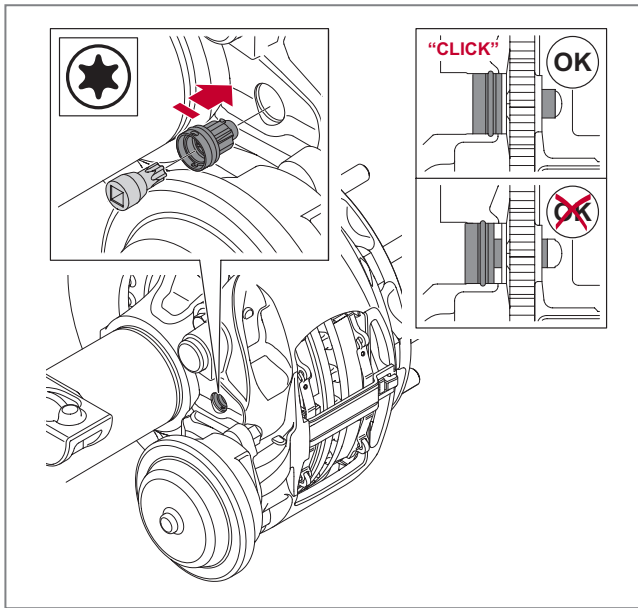

Fig. 74 - Installing the reset shaft

3. Push the reset shaft into position by hand. No impact or high forces are required as they may damage the reset shaft. The reset shaft will click into its position when fully engaged, see ► Fig. 74.

#### 5.6.4 Final procedure

To conclude this procedure, read and follow chapters:

1. „3.3 Function test“, to ensure that the disc brake is working correctly.
2. „3.4 Final procedure“

## 5.7 Replacing the disc brake

### 5.7.1 Initial procedure

Read and follow the chapters below prior to removing the disc brake.

1. „3.2 Initial procedure“
2. „5.2.2 Removing the brake pads“
3. „5.3.2 Removing the brake chamber“

### 5.7.2 Removing the disc brake



#### Caution!

Do not remove the disc brake retaining bolts until the weight of the brake calliper is supported by the lifting device.

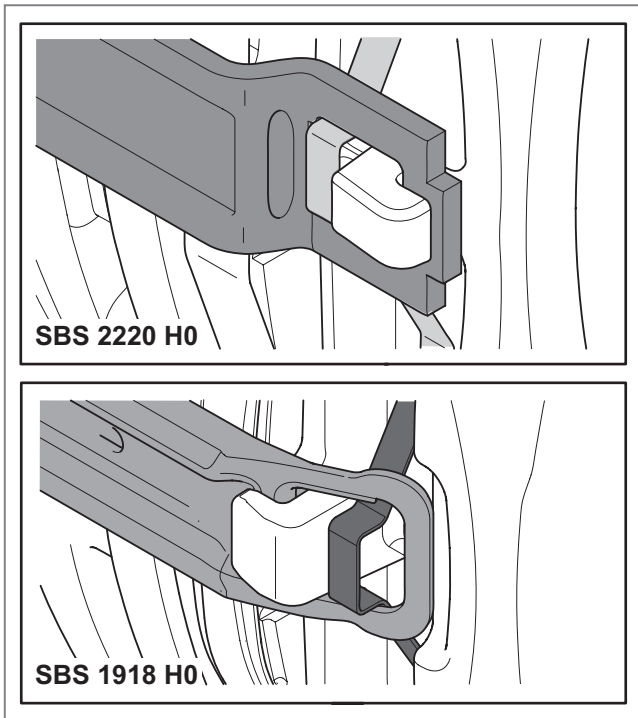

Fig. 75 - Removing the disc brake

1. Refit the old pad retainer by first locating the pad retainer in the housing end in the brake calliper aperture. Then place the rectangular aperture of the pad retainer over the brake calliper seal. Finally, slide the pad retainer under the brake calliper seal until the spring of the brake pad retainer engages in the locking position, see ► Fig. 75.



#### Caution!

Check that the spring bracket is correctly engaged!

2. Secure a lifting sling around the pad retainer. Tension the lifting sling, taking the full weight of the brake calliper.
3. Remove the retaining bolts holding the disc brake and lift away from the axle.

### 5.7.3 Installing the disc brake

1. Clean the contact surfaces of the new disc brake carrier and axle. Ensure the surfaces are free from dirt, debris, moisture and corrosion.
2. Refit the old pad retainer spring. Refit the old pad retainer by first locating the pad retainer in the housing end in the brake calliper aperture. Place the rectangular aperture over the brake calliper seal. Finally, slide the pad retainer under the brake calliper seal until the spring of the pad retainer engages in the locking position.





**Caution!**

Check that the spring bracket is correctly engaged!

3. Attach a lifting sling around the brake pad retainer and then lift the brake into position.
4. Follow the vehicle/axle manufacturer's recommendations for fitting/tightening the retaining bolts, or follow the general method described hereafter.
5. Fit and screw in the retaining bolts, alternating from side to side of the carrier.
6. Tighten all retaining bolts:  
Start with the locating bolt (blue). The locating bolt should be positioned on the outer aperture of the brake run-out side. The tightening torque is 450 Nm  $\pm$ 30 or 120 Nm  $\pm$ 60°.

7. Remove the lifting sling, old brake pad retainer and brake pad retainer spring. Dispose of the old brake pad retainer and the old pad retainer spring. They must not be re-used.

**5.7.4 Final procedure**

To conclude this procedure, read and follow chapters:

1. „5.2.3 Installing the brake pads“
2. „5.3.3 Installing the brake chamber“
3. „3.3 Function test“, to ensure that the disc brake is working correctly.
4. „3.4 Final procedure“

**6 Specifications**

The air-actuated disc brake SAF SBS 2220/SBS 1918 H0 is supplied as both a left and right-hand version. It is important the correct version is fitted in relation to the normal wheel/brake disc rotation.

Each brake calliper bears a rotation arrow on the cast surface. It is located at the point where the pad retainer is seated on the inside of the brake calliper, see ► Fig. 76.

The direction of the arrow indicates the direction of rotation of the wheel.

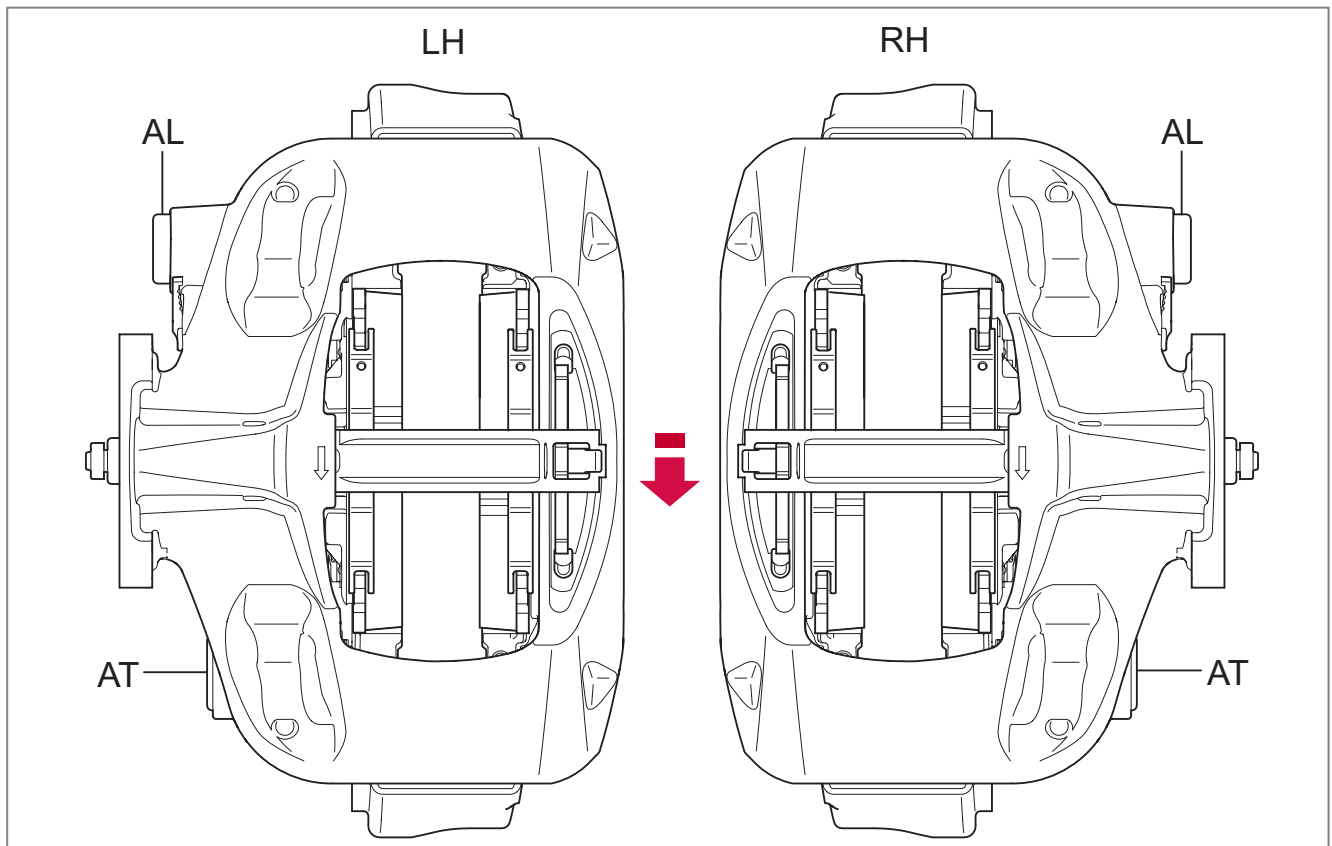

**Fig. 76** - Direction-oriented installation of SAF SBS 2220/SBS 1918 H0

The figure provides a general overview of both versions and their relation to the normal wheel/brake disc rotation (see red arrow), as well as their fixed bearing (AL) and floating bearing (AT) slide functions.

## 6.1 Wear limits

### Wear limits

Brake pads, min. pad thickness	2 mm
Brake pads, max. uneven wear	±1.5 mm
Brake disc, min. thickness	37 mm

## 6.2 Tightening torques

### 6.2.1 General

Follow the vehicle/axle manufacturer's recommendations.

### 6.2.2 SAF SBS 2220/SBS 1918 H0

#### Tightening torques

Bolt connection	Tightening torque [Nm]
Retaining bolts x 2 for guide pins	180 Nm + 70°
Brake chamber fastening nuts	180 Nm + 210 Nm
Brake calliper bolted connection	450 Nm ± 30
	120 Nm + 60°

## 7 Tools

### 7.1 SAF special tool for SBS 2220 H0

The listed tools are part of the SAF Universal Toolbox for disc brakes P/N 3 434 3328 01 or available as an additional set P/N 3 434 3335 00 for the existing SAF Universal Toolbox.

#### SAF special tool for SBS 2220 H0

SAF no.	Designation
P/N 4 434 3837 00	Threaded spindle TR20 x 2
P/N 4 434 3848 0	Thrust bearing
P/N 4 434 3841 0	Nut TR20 x 2
P/N 4 434 3890 0	Pressure fitting SBS 2220 H0
P/N 4 434 3889 00	Sleeve SBS 2220 H0
P/N 4 434 3884 00	Sleeve SBS 2220 H0
P/N 4 434 3888 00	Right puller SBS 2220 H0
P/N 4 434 3887 00	Left puller SBS 2220 H0
P/N 4 434 3885 00	Mounting clip SBS 2220 H0
P/N 4 434 3886 00	Press-in plug SBS 2220 H0

## 8 Fault finding

### 8.1 General fault finding instructions



#### Caution!

Risk of serious traffic accidents which may lead to serious or fatal injuries!

- Repair work must only be carried out by authorised workshops and by appropriately trained personnel.
- All components which are not in a serviceable condition must be replaced.
- The general safety inspection must be performed in accordance with the legal regulations.
- It is the duty of the driver to perform a daily inspection of the vehicle for traffic safety before starting the journey.

### 8.2 Inspection intervals



#### Caution!

Risk of serious accidents, which may lead to serious or fatal injuries!

- Missing or damaged components must be replaced immediately by an authorised workshop and by appropriately trained personnel.
- In the case of vehicles with extreme operating conditions, the inspection intervals must be reduced.

#### Inspection intervals

	Every month or 10,000 km	Every 3 months or 50,000 km	Every 6 months or 100,000 km	Every 2 years or 500,000 km
General safety inspection in accordance with the legal regulations.				
Visual inspection				
Connecting hoses	X	–	–	–
Electrical cables	X	–	–	–
Function test				
Check control unit for output pressure. First time on commissioning.	–	–	X	–
Check indicator lamp. First time on commissioning.	–	–	X	–
Check pressure pipes through adjustment of system pressure. First time on commissioning.	–	–	X	–

en

## 9 Spare parts and repair kit list

Spare parts and repair kits for compressed-air disc brake SAF SBS 2220/SBS 1918 H0.

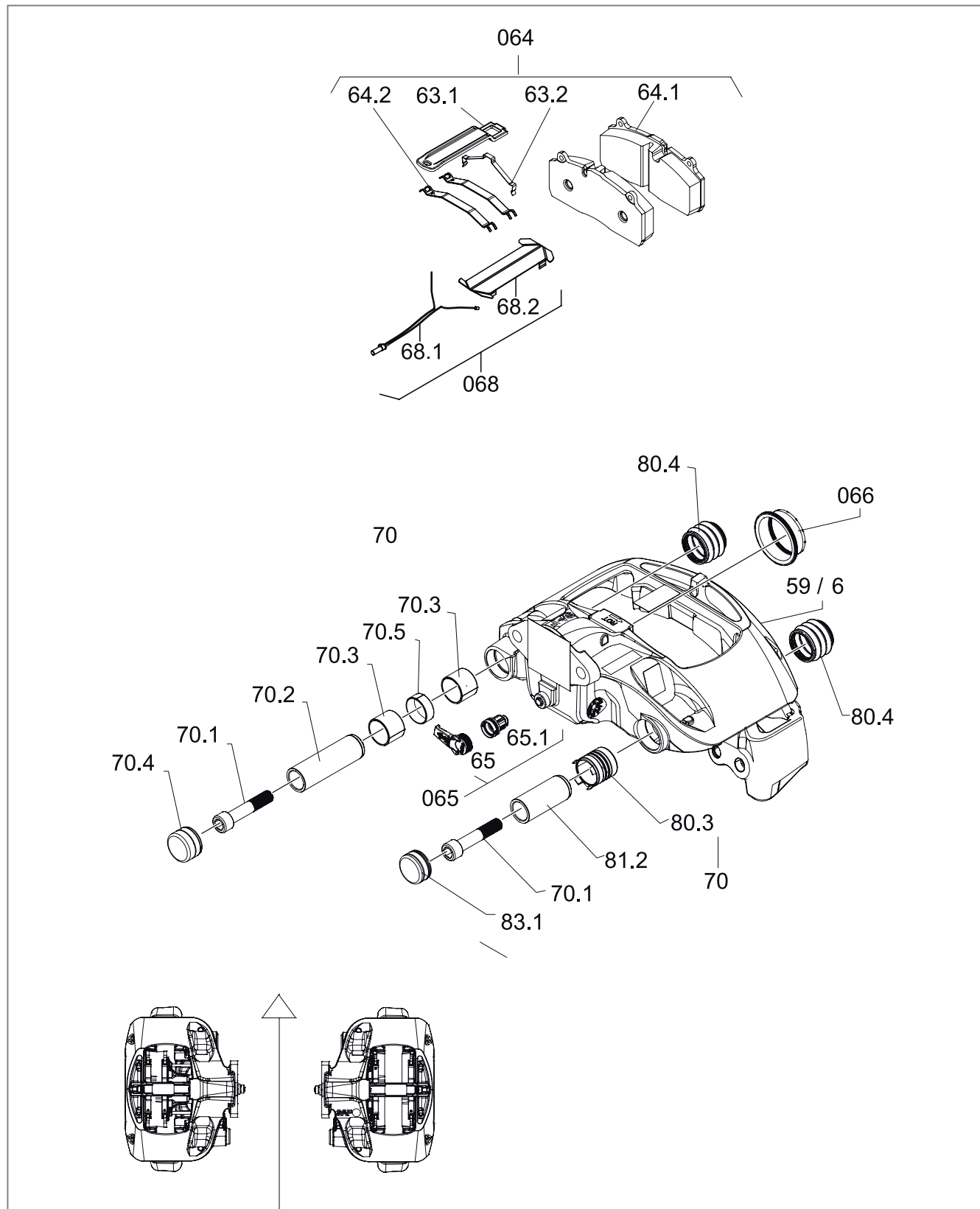

Fig. 77 - Spare part illustration

**Spare parts and repair kits**

Item no.:	Number	Description	Order no.
<b>059</b>	1	<b>Left brake calliper group</b> SBS 2220 H0 SBS 1918 H0	<b>03080008100</b> <b>03080008500</b>
<b>060</b>	1	<b>Right brake calliper group</b> SBS 2220 H0 SBS 1918 H0	<b>03080008200</b> <b>03080008600</b>
<b>064</b>		<b>Brake pad kit 22.5" – item 63.1, 63.2, 64.1, 64.2:</b> <b>SBS 2220 H0</b>	<b>03057009600</b>
		<b>Brake pad kit 19.5" – item 63.1, 63.2, 64.1, 64.2:</b> <b>SBS 1918 H0</b>	<b>03057001400</b>
63.1	2	Pad retainer spring bracket SBS 2220	cannot be ordered individually
63.2	2	Securing clip SBS 2220	cannot be ordered individually
64.1	4	Brake pad 22.5"	cannot be ordered individually
64.2	4	Spring clip	cannot be ordered individually
<b>065</b>		<b>Reset shaft group - item 65, 65.1</b>	<b>03434386200</b>
65	1	Adjuster plugs	cannot be ordered individually
65.1	1	Adjustment screw	cannot be ordered individually
<b>066</b>		<b>Pressure fitting seal kit</b>	<b>03434386300</b>
<b>068</b>		<b>Wear indicator kit</b>	<b>03424203300</b>
68.1	2	Brake pad wear indicator	cannot be ordered individually
68.2	2	Mounting plate	cannot be ordered individually
<b>70</b>		<b>Guide and seal kit</b>	<b>03434386100</b>
70.1	2	Torx bolt	cannot be ordered individually
70.2	1	Guide pin	cannot be ordered individually
70.3	2	Bearing	cannot be ordered individually
70.4	1	Protective cap	cannot be ordered individually
70.5	1	Slide bearing	cannot be ordered individually
80.3	1	Bushing	cannot be ordered individually
80.4	2	Bellows	cannot be ordered individually
81.2	1	Guide pin	cannot be ordered individually
83.1	1	Protective cap	cannot be ordered individually





**Emergency hotline**

**+49 6095 301-247**

**Customer Service**

**+49 6095 301-602**

**Fax**

**+49 6095 301-259**

**[service@safholland.de](mailto:service@safholland.de)**

**[www.safholland.com](http://www.safholland.com)**

XL-SA3000RM-en-DE Rev A • 02.2016 • Errors and changes excluded © SAF-HOLLAND

SAF-HOLLAND GmbH  
Hauptstraße 26  
D-63856 Bessenbach

