

Launch of new drum brake SNK300x200S for 12t in July 2016

The SNK 300x200 brake size has a range of application covering axle loads from 6t to 12t. The large number of variants and the increasingly strict ECE R13 legal requirements made it necessary to develop a special solution for 12t applications. SAF-HOLLAND has thus re-worked the SNK brake in order to continue to be able to meet customer requirements. The result is the new **SNK300x200S** brake for a max. **axle load of 12t**.

As well as various construction changes, the new brake has the optimized **SAF636** brake lining. This lining has been specially developed for use with 12t axle loads.

Its benefits:

- Application-specific brake lining fade value
- Adjustment of braking factor
- Brake fade stability over the entire service life of the lining.
- Brake fade stability related to temperature, speed and pressure.

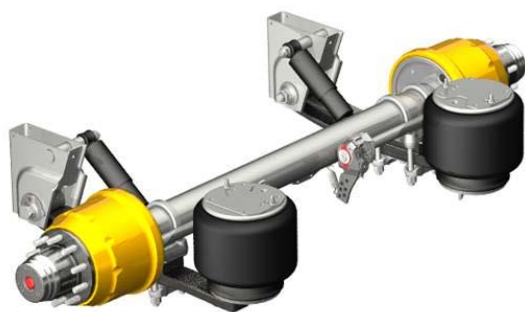

Fig. 1: SAF SKxxxx 12030S

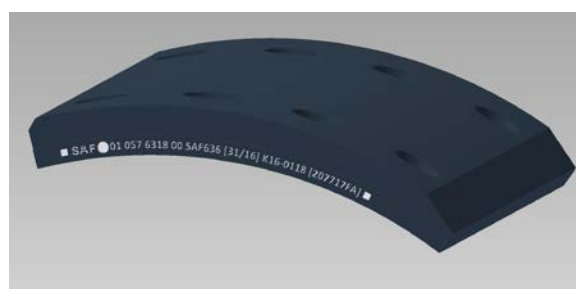

Fig. 2: Brake lining SAF636

The new brake will be launched as part of the changeover from the familiar SKxxxx 12030 axle versions to the new **SKxxxx 12030S** axle version. This applies for all rigid and steering axles.

	Axle model	Axle type	Brake type	Test report	Axle load
old	SKxxxx 12030	SNK3020	SNK300x200	TDB0487	11.6t
new	SKxxxx 12030S	SNK3020	SNK300x200S	TDB0882	12t

With the changeover to the new SKxxxx 12030S axle version, there are **no changes** to the operating, service and maintenance manuals.

Please note:

The brake must be added to the existing systems and vehicle authorization documentation. The required information is available in advance from our homologation department: Mr Schreck, Telephone: +49 6095 301 382, E-mail: robert.schreck@safholland.de, and also on our website soon.

Launch of new drum brake SNK300x200S for 12t in July 2016

The changes are scheduled to be implemented in July 2016. From then onwards, it will be the changed versions of these axles that are delivered.

Please note that the SKxxxx 12030 axle version will only be available after the changeover for replacements.

Please update your master data and ordering data accordingly.