

TRILEX[®] UNIVERSAL WHEEL SYSTEM
TUBLEX[®] N-RIMS

Operating instruction

the original



TRILEX®

Operation – Assembly – Maintenance

Table of contents

Safety symbol description	26		
1. General safety information		7. Disassembly of rims with tyres from the wheelspider	
1.1 User responsibility	27	7.1 TRILEX® wheel with single tyre	41
		7.2 TRILEX® wheel with twin tyres	41
2. Product description		8. TRILEX® wheel rim with double clamp	42
2.1 Features of the TRILEX® spoked wheel	29		
3. Elements of the TRILEX® wheel		9. Tools for assembly and disassembly in the TRILEX® system	43
3.1 Single TRILEX® wheel	31		
3.2 Double TRILEX® wheel	32		
4. Assembly / disassembly of TRILEX® rims			
4.1 Assembly	33		
4.2 Disassembly	35		
5. Assembly / disassembly of TUBLEX® rims			
5.1 Assembly	36		
5.2 Disassembly	37		
6. Assembly of TRILEX® rim with tyre on the wheelspider			
6.1 General information	38		
6.2 Single TRILEX® wheel	39		
6.3 Double TRILEX® wheel	39		

Safety symbol description

The following safety symbols appear in this operating manual. These symbols are used to make the user aware of relevant safety information.



Danger

This symbol warns of dangers to health and safety of personnel.



Caution

This symbol warns of dangers to machine parts, materials or the environment.



Note

This symbol shows information that clarifies machine operations.

1 General safety information

1.1 User responsibility

The TRILEX® wheel has been designed and constructed according to a careful selection of norms, consideration of dangers and further technical specifications. It thus complies with modern technological standards and provides the highest levels of safety.

This high level of safety can only be achieved during regular operation if all the measures required for it have been taken. The vehicle operator is responsible for planning these measures and ensuring that they are carried out correctly.

The operator must especially ensure that the following requirements are met:

- The TRILEX® wheel may only be used as intended (refer to Chapter 2.1 «Product description»)
- The wheel may only be used in a fully functional and technically flawless state. The functioning of the safety equipment must be inspected on a regular basis
- The necessary safety equipment must be provided for operating, servicing and repair personnel and used correctly
- The operating manual must remain at the usage site at all times and be complete and fully legible
- Personnel must be regularly trained in all aspects of work safety and environmental protection and must be aware of the safety information contained within the operating manual
- All safety and warning notices on the wheel must remain in place and be fully legible



Note

This operating manual must be kept in the vehicle. It must be ensured that all personnel who work with the vehicle can access the operating manual at all times. In addition to the operating manual, other material concerning labour protection laws and regulations for equipment use should be provided.

All safety information and operating signs on the wheel must always be kept in a fully legible condition. Damaged or illegible signs must be replaced immediately.

2 Product description

2.1 Features of the TRILEX® spoked wheel

TRILEX® rims can be easily mounted and disassembled since the rim profile is divided cross-sectionally.

TRILEX® rim segments of the same rim size can be exchanged with one another. In the event of damage, only the corresponding segment must then be replaced.

The centring of TRILEX® wheels guarantee zero run-out of rims and tyres when professionally mounted.

TRILEX® wheels enable tensioning of the rims at the greatest possible diameter: Therefore only 6, 8 or 12 (for double clamps) screws are required.

The profiling of TRILEX® wheels enables ventilation of the brakes and rims.

The TRILEX® wheelspider is manufactured of the highest quality material and its profiling enables it to meet the highest demands. Together with the TRILEX® rim, it forms a single unit of long service life.



Note

For reasons of safety, only TRILEX® original spare parts with the «TRILEX®» trademark should be used.



Caution

Proper use includes with it the reading of this operating manual, including all operating and safety instructions. All inspection and maintenance work must also be carried out at the specified time intervals.



Caution

If the TRILEX® wheel is not used as described, safe operation cannot be guaranteed.

The vehicle operator, not the manufacturer, is responsible for all injuries and material damage resulting from improper use.

3 Elements of the TRILEX® wheel

3.1 TRILEX® wheel with single tyre

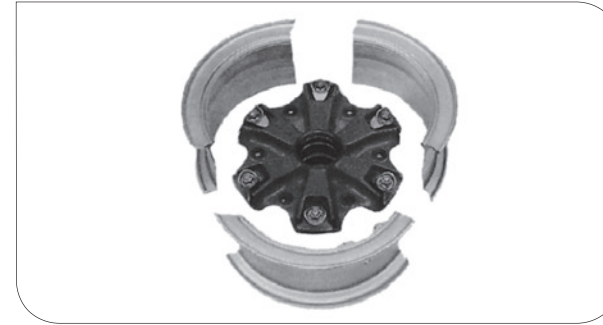

Functioning principle

- 1 wheelspider or rim
- 1 TRILEX® rim kit (3 pieces)
- 6 TRILEX® screws with flanged nuts and spring clips
- 6 clamping plates (A version with 8 or 12 clamping holes is also available)

All components are identified with parts numbers, which must be specified when placing spare parts orders. On TRILEX® wheelspiders and rims, the part numbers have been ingrained on the inner or outer side.

3.2 TRILEX® wheel with twin tyres

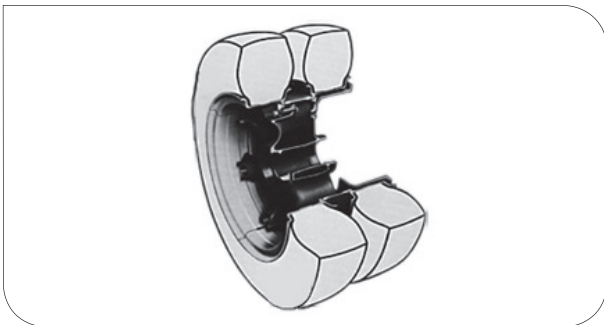

- 1 wheelspider
- 2 TRILEX® rim kit (6 pieces)
- 1 spacing ring
- 6 TRILEX® screws with flanged nuts and spring clips, U-washers if used
- 6 clamps (A version with 8 clamping holes is also available)

General information

For individual custom designs, special versions of accessory parts are used.

4 Assembly / disassembly of TRILEX® rims

4.1 Assembly of TRILEX® rims

Coat tyre beads and bead chafer strip with tyre mounting paste. This facilitates the mounting and later removal and prevents the tyre from adhering tightly to the rim. Clean any rusted rims in the tyre contact area and coat with rust protection paint (zinc-rich paint).



Note

Insert the valve segments at an angle.



Caution

Lay the valve with the arrow-indicated side in the slot. The rim base must lay against the tyre beads over the entire segment length. For retreaded tyres, which usually have a large bead width, press together if necessary.

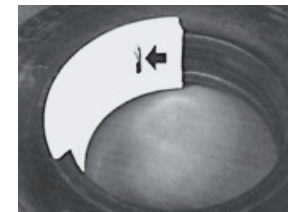

Note

Place the second segment in front of the valve segment so that there is room for the third segment.

Insert the third segment and connect to the valve segment.

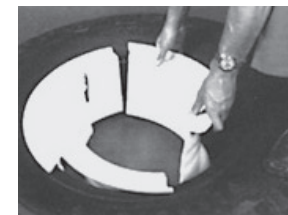

Note

Push the segment in front of the valve segment into the closure position.

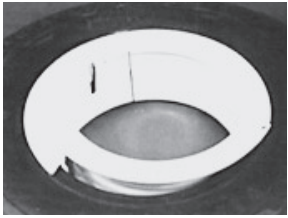

Check the position of the valve!

Caution

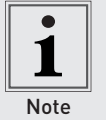
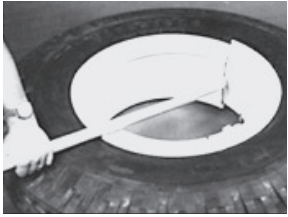

Using uniform pressure along the rim flange, close the rim with the double lever (659 800 008). (Do not pull the lever upward!) For assembly in transit, the closing lever (659 800 006) can also be used by inserting the opening lever (659 800 007).

Note

When the rim is mounted, the valve must lie in the centre of the valve slot.

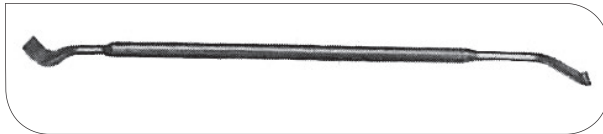

Double lever (659 800 008)

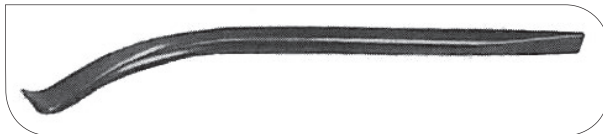

Closing lever (659 800 006)

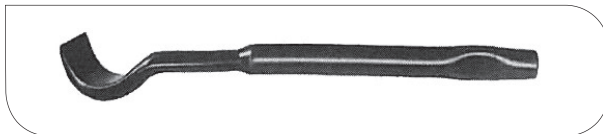

Opening lever (659 800 007)



Important note on assembly

In order to ensure a functionally correct placement of the rim on the wheelspider, care should be taken during the mounting of the rim that the tyres are pre-filled to a pressure of from 1 to 3.5 bar. During pre-filling, it should be ensured that the rim joints do not show any overlap in the axial direction. If this occurs, the protrusions should be made flat with a rubber hammer. Tyres with a higher filling pressure can cause mounting problems on the wheel rims or wheelspiders. Secure attachment of the rim toes is then not ensured. Twisting on the wheelspiders or rims can thereby occur.

Caution

4.2 Disassembly of TRILEX® rims



Fully deflate the tyres.

Before opening the rim, pressing or releasing the tyre beads from the rim flange is recommended.

Caution

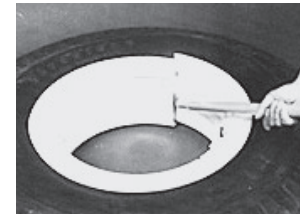

Open rim with double lever (659 800 008).
(Fig. on page 34)

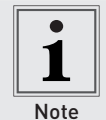

Using the TRILEX® disassembly device (659 801 006) enables you to perform the disassembly simply and quickly.

(Use only for 20" and 24" rims)

Note

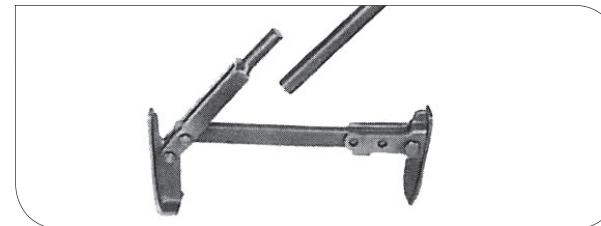
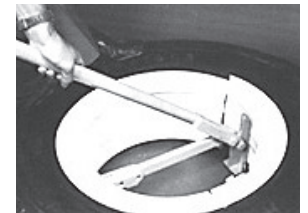

TRILEX® disassembly device (659 801 006)

5 Assembly / disassembly of TUBLEX® rims

5.1 Assembly of TUBLEX® rims



Note

Brush tyre and rim liberally with tyre mounting paste. The short side of the rim shoulder should be on top. Press the tyre manually into the drop centre at the point opposite the valve and pull it as far as possible over the rim flange.

Required tools:

2 two-sided levers 659 800 00

Tyre mounting paste 659 144 002



Note

Unseat the tyre bead over the rim flange using the straight lever end.



Note

Press the second tyre bead opposite the valve into the drop centre on one side.



Note

Press the tyre bead over the rim flange using the bent lever ends.

5.2 Disassembly of TUBLEX® rims



Note

The short side of the rim shoulder should be on top. Unseat the tyre bead from the rim flange. Push both bent lever ends between tyre and rim two hand widths apart at the valve.

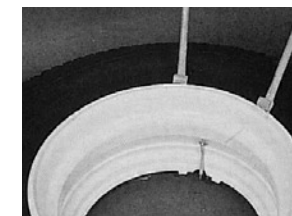

Required tools:

2 two-sided levers 659 800 000



Note

Press the tyre into the drop centre at the point opposite the levers and pull the tyre bead over the flange with a uniform pulling of both levers.

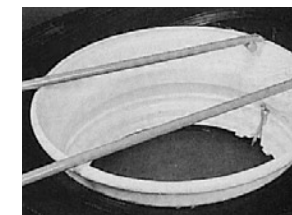

Note

Insert the lever again into the junction (see arrow) of the already lifted bead and pull the rest of the bead over the rim flange. Repeat the process as necessary until the entire bead is pulled over the rim flange.

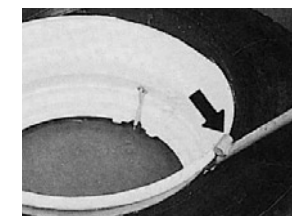

Note

Align tyre with the asymmetrically longer side of the rim shoulder pointing toward you. Insert the straight lever ends as far in between tyre bead and rim flange until the ends of the lever are against the flange.

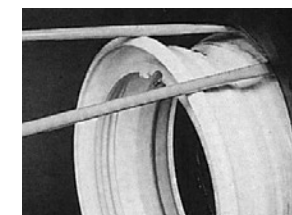

Note

Tilt the tyre and free the rim by rocking the levers.



6 Assembly of rim with tyres on the wheelspider

6.1 General information



Caution

Clean all components such as spoke heads, rim toes, screws and clamping parts. To achieve a technically flawless tensioning and centring of the rim, the spoke heads and rim toes should not be coated with paint.



Note

Permitted tightening torque of the nuts in the TRILEX® wheel system:

- 270 – 300 Nm for M 18 screws
- 320 – 360 Nm for M 20 screws



Caution

The nuts of the fastening screws should always be tightened sequentially (never crosswise) in 3 to 4 passes.



Danger

When using an impact wrench, the prescribed torque is to be observed as specified.



Note

Note that the final filling of the tyres with compressed air is to be performed only after the assembly process has been properly completed. (The filling pressure depends on the tyre manufacturer.)

6.2 Single TRILEX® wheel



Caution

Check that the brake drums have holes for the valve. When seating the rim, the valve must lie with both ends between 2 spoke heads. Mount the upper and lower clamping plates first (secure them with nuts only until hand-tight). Then fit the remaining clamping plates and tighten the nuts in sequential order (**not crosswise**) in 3 to 4 passes. Observe the tightening torque specified for the respective screws.



Danger

After a brief test run (approx. 5 – 10 km), as well as after a further 100 km, the nuts must be inspected for proper torque and tightened if necessary.

6.3 Double TRILEX® wheel

Mounting the inner wheel.



Caution

Check for holes for the valve.

The spacing ring is inserted.





Note

Align the lugs of the spacing ring with the spoke head between the spokes.

The outer rim can then be mounted.



Note

Mount the upper two clamps first and tighten with nuts until only hand-tight. Insert the remaining clamps.



Caution

Then fit the remaining clamping plates and tighten the nuts in sequential order (not crosswise) in 3 to 4 passes. Observe the tightening torque specified for the respective screws.



Danger

The following also applies to twin tyres: After a brief test run (approx. 5 – 10 km), as well as after a further 100 km, the nuts must be inspected for proper torque and tightened if necessary.

7 Disassembly of rims with tyres from the wheelspider

7.1 TRILEX® wheel with single tyre



Note

Release and unscrew nuts, remove clamping plates and lift up rims.



7.2 TRILEX® wheel with twin tyres



Danger

Release the nuts gradually over several passes; never completely remove from the screw. Unseat the clamping plates with the hook of the opening lever (659 800 007).



Opening lever (659 800 007)



Note

Completely release or disassemble the nuts and clamps. Lift the outer rim, spacing ring and inner rim from the wheelspider.

8 TRILEX® wheel rim with 24" double clamp

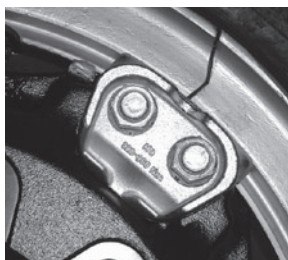

Note

Increased braking pressure (over 10 bar) on the front axle! A wheel rim with double clamp is recommended for this.

Parts for one front axle

- 2 wheel rims
- 12 clamping plates
- 24 TRILEX® screws
- 24 flanged nuts
- 24 spring clips
- 2 TRILEX rim kits



Note

Also applies to double clamps:
When tightening the nuts in individual passes, always start with the first nut (in the clamping plate) on the right next to the valve.

For disassembly, the same procedure is performed as with single clamps.

9 TRILEX® tools for assembly and disassembly

Tools for mounting TRILEX® rims

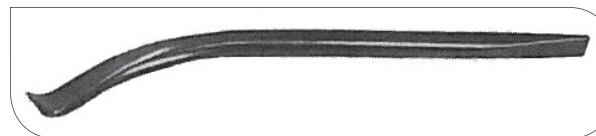

Closing lever

(order no. 659 800 006)



Opening lever

(order no. 659 800 007)

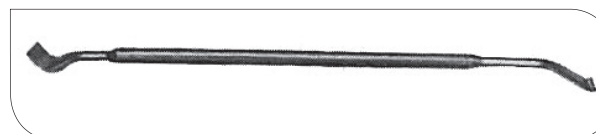

Double lever

(order no. 659 800 008)

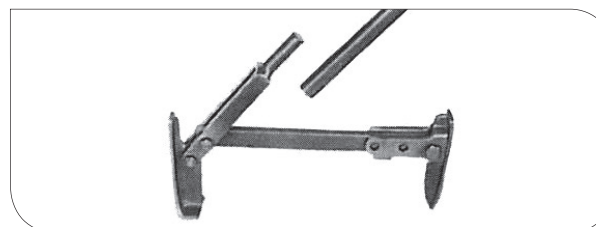

TRILEX® disassembly device (order no. 659 801 006)

For the care of tyres and rims



Mounting paste (5 kg)

(order no. 659 801 006)

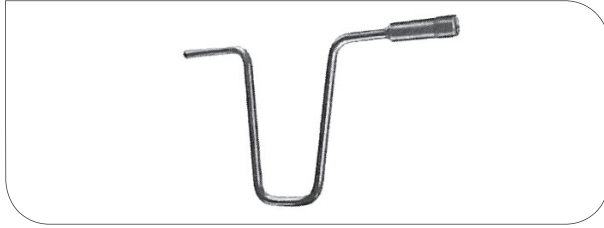
Tools for assembling wheelspider and rim

Nut winch

(order no. 659 800 021)

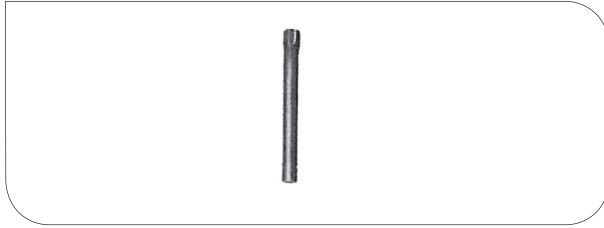

Socket wrench

(order no. 659 800 038)



Mandrel

(order no. 659 800 039)

TUBLEX® assembly and disassembly leverTUBLEX® assembly and
disassembly lever

(order no. 659 800 021)



Engineering Your Road to Success

SAF-HOLLAND is a leading supplier of highly efficient components, systems and service programmes in the global commercial vehicle industry. Our three core product brands are recognised for delivering innovative solutions that optimise fleet operations in every corner of the world.



TRAILER AXLES AND
SUSPENSION SYSTEMS



COUPLING AND LIFTING
TECHNOLOGY



SUSPENSIONS FOR
TRUCKS AND BUSES

With our team of over 3,000 employees and a worldwide network of over 9,000 service partners, we serve our fleet customers with know-how and passion, and always focus on one target: **Engineering Your Road to Success.** Anywhere in the world. Under any conditions. 365 days a year.

HIGHLY EFFICIENT COMPONENTS AND SYSTEMS FOR TRUCKS AND TRAILERS



EUROPE | NORTH AMERICA | SOUTH AMERICA | AFRICA | ASIA | AUSTRALIA

safholland.com

SAF-HOLLAND GmbH

Hauptstraße 26 · 63856 Bessenbach · Germany
Tel +49 6095 301-0 · info@safholland.de