

SAF-HOLLAND INTRODUCES THE EASY-BAR™ CRANK HANDLE

The Easy-Bar is an ergonomic landing gear crank handle created by an expert with many years of trucking industry experience. Its ergonomic two hand operation requires minimal effort, allowing the trucker to complete the cranking task quickly and easily.

Manufactured with 14 gauge steel and coated in electrostatic paint the Easy-Bar crank is solid and resistant. The cast steel head provides incredible durability under the toughest climatic conditions, year after year.

SAFE

No more backaches muscle strains or other forms of injury caused by using conventional model handles. The innovative Easy-Bar crank handle uses the rotating movement that is more natural than conventional crank handles. Easy-Bar allows truck drivers to work in a perfectly straight and safe position.

EASY

The innovative Easy-Bar is specially designed to enable the use of both hands. It requires minimal effort and simplifies the task of the driver without losing speed. You can use the Easy-Bar in two positions, as a standard crank handle for maximum torque, or in the 45 degree position for maximum speed.

EASYBAR™
for trailers



Using conventional handles is often the cause of facial injuries, knee problems and chronic back pain.

EASY-BAR™ CRANK HANDLE

PART NUMBER
50644036

\$83.45 CAD
LIST PRICE

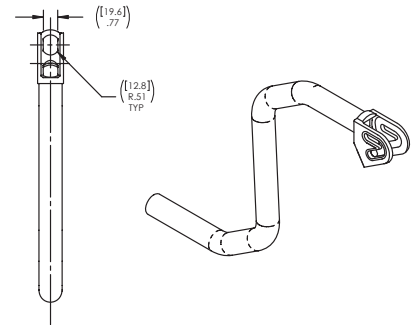
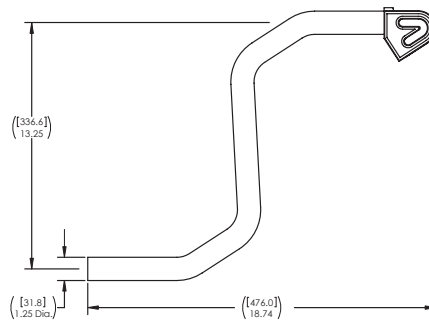

Easy-Bar can be used with most semi-trucks with it's ADJUSTABLE ADAPTOR.

Optional Adaptor Not Included.

OPTIONAL EASY-BAR™ ADAPTER

PART NUMBER
50644037

\$35.10 CAD
LIST PRICE

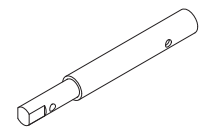
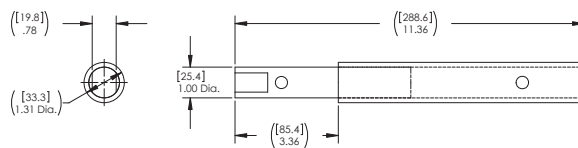

The Easy-Bar fits most landing models with an optional adjustable adaptor. The Easy-Bar Adapter 50644037 can be used to convert round crankshafts to flat driven crankshafts. It can also be used to adjust the length of the crankshaft to provide proper clearance from the outside of the trailer. Use only in applications that do not exceed 100lbs of torque on the crank handle.

OPERATION INSTRUCTIONS



The Easy-Bar crank handle can be used in the standard position for maximum torque capability, or for the maximum speed cranking position, simply pull the crank handle out and away from the shaft and rotate to the 45 degree position. Push the handle back onto shaft and you are ready for speed cranking.

WARRANTY

We warrant, to the original purchaser, the Easy-Bar crank handle and adapter, when properly installed on the vehicle and maintained and operated in accordance with our recommendations for a period of 12 months. You are responsible for the proper installation, maintenance, and operation of the Easy-Bar product as specified above and for using the product in recommended applications within the rated capacity. This warranty does not cover any product or component that is altered without written permission, or fails, malfunctions or is damaged as a result of accident, abuse, or improper installation, maintenance, or use. This warranty is our sole warranty in regard to covered Easy-Bar. We make no other warranties expressed or implied, or of merchantability or fitness for a particular purpose. In no event shall we be responsible special, incidental, or consequential damages of any kind.

SAF-HOLLAND Canada Limited

519.537.3494 FAX 800.565.7753

Western Canada 604.574.7491 FAX 604.574.024

www.safholland.com

SAF Holland
Engineering Your Road to Success