



COUPLER PRODUCTS

LATCH REPLACEMENT PROCEDURES

(PH-30 shown)



RK-05643

For PH-30 and PH-35

1. Remove and discard the nut, pivot bolt, and latch assembly.

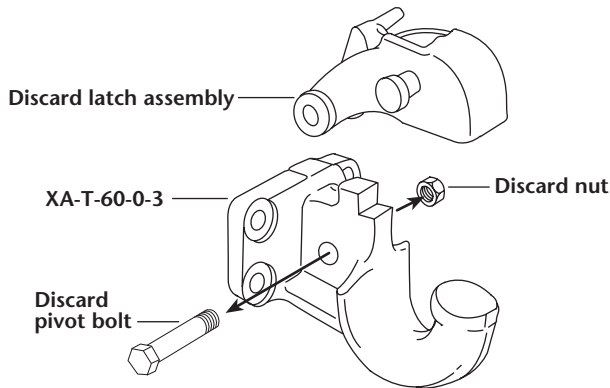

2. Apply Never-Seez® to entire shaft of the new pivot bolt (not on threads).

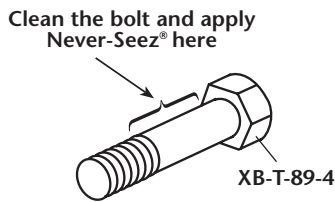

3. Install the new latch assembly using the new pivot bolt and lock nut provided in the kit. Tighten bolt until it contacts the cast lock and then turn nut an additional 1/4 turn. Visually confirm that there is at least one full thread on the bolt protruding beyond the lock nut. If, during assembly, it becomes necessary to remove the lock nut, discard and use second nut provided in the kit.

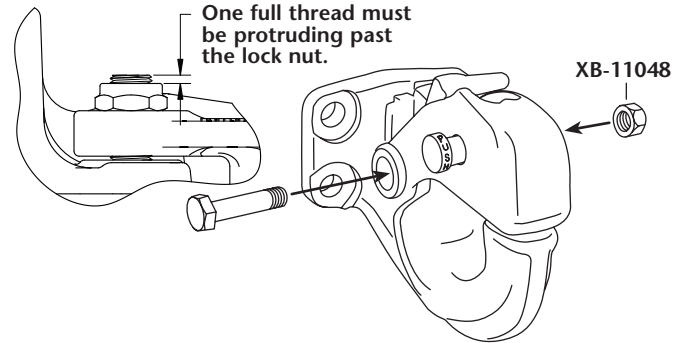

⚠ WARNING DO NOT reinstall a removed lock nut. Always install a new lock nut when removing or replacing latch assembly. A reinstalled nut may not retain properly and could result in an unintended trailer separation.

4. To close, rotate the latch down until it locks. Check to be sure the lock has returned to its locked position under the ledge of the latch.

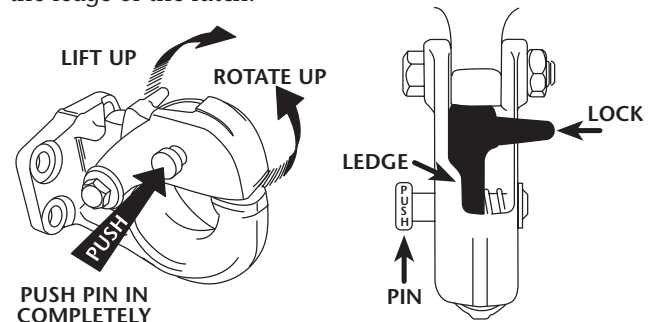

Copyright © January 2007 • The Holland Group, Inc.

Holland USA, Inc. Facilities:

Dumas, AR Muskegon, MI
 Holland, MI Warrenton, MO
 Monroe, NC Wylie, TX

Ph: 888-396-6501 Fax: 800-356-3929

Holland International, Inc.

Holland, MI
 Phone: 616-396-6501
 Fax: 616-396-1511

Holland Hitch of Canada, Ltd.

Woodstock, Ontario • Canada
 Phone: 519-537-3494
 Fax: 800-565-7753

Holland Equipment, Ltd.

Norwich, Ontario • Canada
 Phone: 519-863-3414
 Fax: 519-863-2398

Holland Hitch of Canada, Ltd.

Surrey, British Columbia • Canada
 Phone: 604-574-7491
 Fax: 604-574-0244

www.thehollandgroupinc.com