

Aufbau - Bedienung - Wartung Mounting - Operation - Maintenance

Verschiebeeinrichtung
Slider

SK-V 20

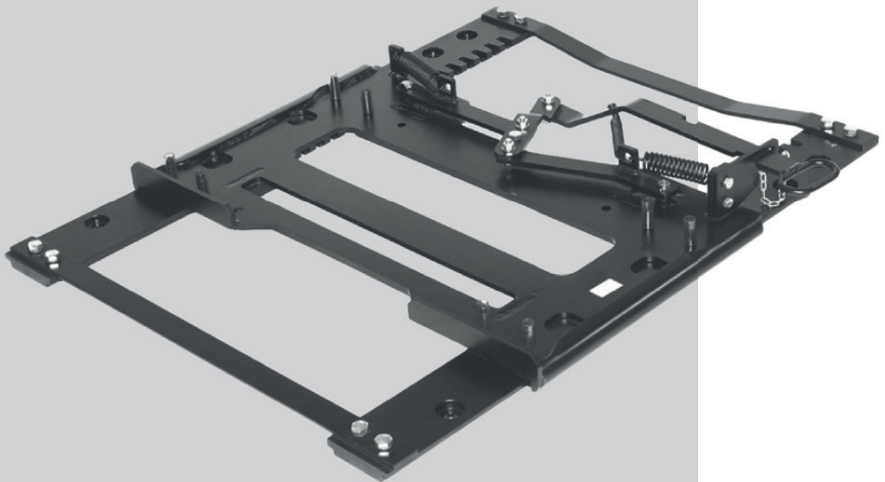

Technical Data

The Slider SK-V 20 is designed for use with fifth wheels, designed in accordance with Directive 94/20 EG and DIN 74081

The Slider is suitable for fifth wheels which are suitable for attachment to automatically-steered semitrailers. The steering wedges on semitrailers must correspond to the dimensions in accordance with EC 94/20, Appendix V, Section 7.9.1.

Maximum imposed load:	18 t
Maximum D-Value:	135 KN
EG-approval number:	e11-00-5482

Basic Version

Without fifth wheel

Installation height	35 mm
Weight	110 kg

With fifth wheel

Installation	185 mm	220 mm	260 mm	285 mm
Weight	222 kg	225 kg	229 kg	233 kg

Table of contents

Mounting instructions	23
Operation	26
Locking and unlocking the slider (manually operated)	26
Locking and unlocking the slider (pneumatically operated)	28
Manual conversion – pneumatically operated	29
Disassembling the manual locking mechanism	30
Assembling the pneumatically operated locking mechanism	31
Connecting to the vehicle pneumatics	34
Maintenance	35
Before initial commissioning	35
Maintenance intervals	36
Repairs	38
Locking wedges	38
Carriage, complete / Locking wedge guides	39



General information

Failure to follow these instructions can lead to dangerous operating conditions. Before mounting the slider and putting it into service, please read and follow the instructions.

- Modifications of any kind preclude guarantee claims and invalidate product type approval.
- The mounting of fifth wheel, mounting plate, slider and kingpin, as well as repair work, should only be performed by qualified specialists in workshops suited for this.
- If the service and repair work specified in the manual is not adhered to, SAF-HOLLAND take no responsibility for the function and reliability components.

Mounting instructions

- For the mounting of the slider, the mounting instructions of the respective commercial vehicle manufacturer and those of SAF-HOLLAND are to be observed.
- The slider is mounted directly (without an intermediate plate) on the vehicle auxiliary frame. For the mounting, we recommend the corresponding mounting kits from SAF-HOLLAND.
- The slider must be adjusted for the coupling point recommended by the vehicle manufacturer and taking into account the desired sliding distance.
- The design of the slider is dependent upon:
 - vehicle auxiliary frame width
 - number of axles (4x2, 6x2, 6x4 etc.)
- If a coupling point is mounted on the slider, the applicable mounting instructions must be observed.
- The specifications of the automobile manufacturer regarding tightening torque are to be strictly observed.

- The slider must be mounted with the following minimum number of fasteners and torques:

16 x M14 - 10.9	$M_{a \text{ min.}} = 170 \text{ Nm}$
12 x M16 - 10.9	$M_{a \text{ min.}} = 250 \text{ Nm}$
12 x M18 - 10.9	$M_{a \text{ min.}} = 350 \text{ Nm}$
12 x M20 - 8.8	$M_{a \text{ min.}} = 340 \text{ Nm}$

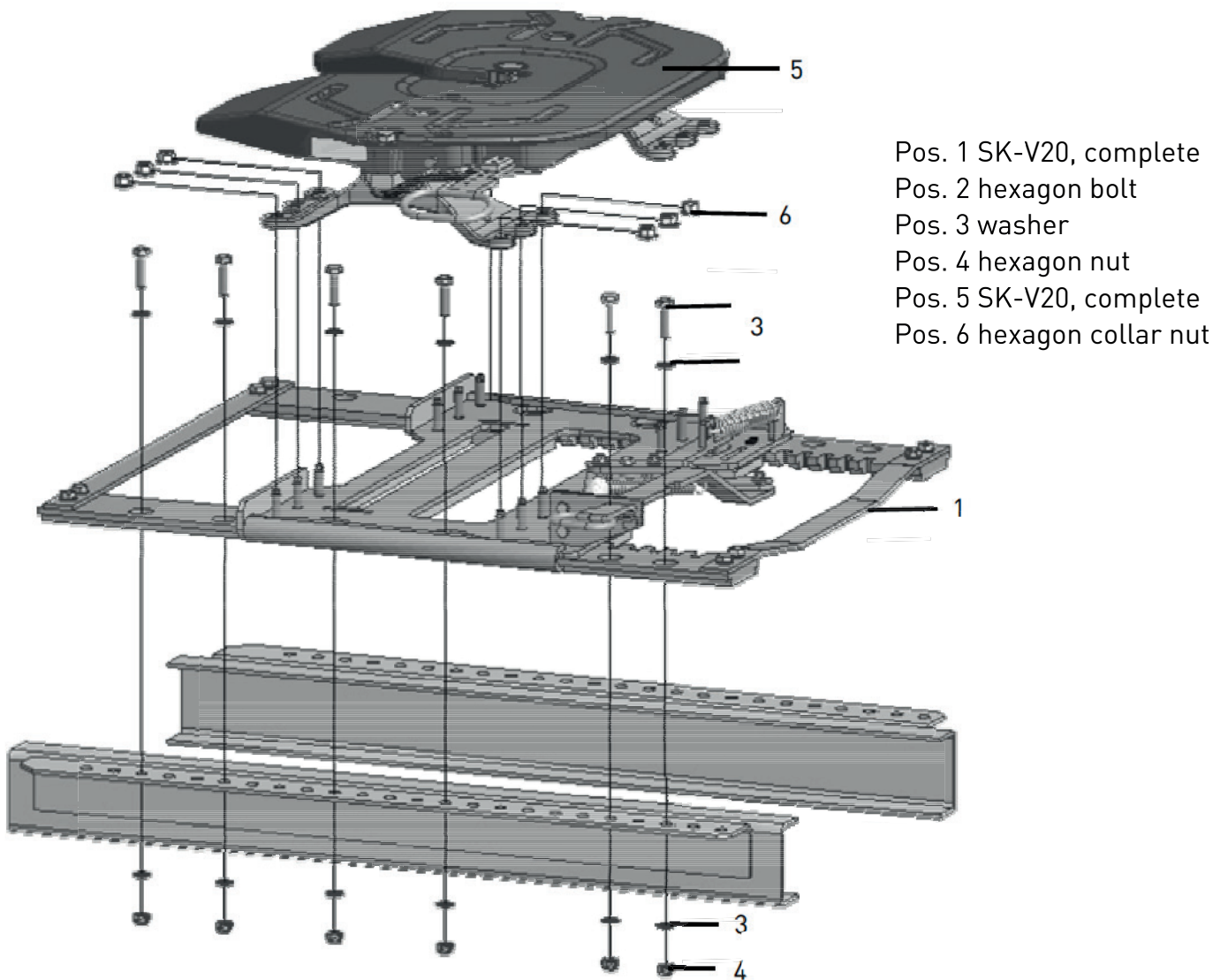

- Note** In the exploded view above, only one possible assembly version is shown. Depending on vehicle type, different numbers, sizes and sequences of mounting elements are used.
- Note** For the mounting of the SK-V20, it is strongly recommended to use only original mounting kits from SAF-HOLLAND.
- Note** After the first 1,000 km, all screws must be checked for correct torque and tightened if necessary.

- When mounting the slider, the national registration regulations are to be observed.
- Generally, the coat thickness of the paint in the clamping zone of the screw must conform to legal standards in order to avoid impairing the flux. In the Federal Republic of Germany, the TÜV regulations regarding screws and their safety in motor vehicle manufacture are to be observed.
- The coupling plate of the slider carriage must be freely movable and may not contact any part of the slider or the vehicle frame during driving or sliding operation.
- The imposed load and the D-value are the criteria for determining the load capacity of fifth wheels and mounting plates (slider). In the case of several type plates, the lowest specification for imposed load and D-value is decisive.
- The D-value is calculated according to DIN 74081 using the following equation:

Example:

$$D = g \cdot \frac{0.6 \cdot m_K \cdot m_A}{m_K + m_A - A} \text{ in kN}$$

$$D = 9.81 \cdot \frac{0.6 \cdot 20 \cdot 30}{20 + 30 - 15} = 100.9 \text{ kN}$$

Legend:

m_A	= permissible total weight of the tractor in tonnes	m_A	= 20 tonnes
m_K	= permissible total weight of the semi-trailer in tonnes	m_K	= 30 tonnes
A	= permissible imposed load in tonnes	A	= 15 tonnes
g	= acceleration of gravity with 9.81 m/sec. ²		

The permissible load capacities for SAF-HOLLAND fifth wheels and mounting plates (sliders) are specified in the sales catalogue of SAF-HOLLAND. These specifications are applicable for operation on sealed roads and transport conditions common to central Europe. Please consult us if operating conditions differ.

Operation

- It is recommended to perform the sliding with an unloaded trailer.



Note

before unlocking and locking, the vehicle should always be secured against rolling (i.e. by means of a handbrake or wedge placed underneath).

Unlocking the slider (manually operated)

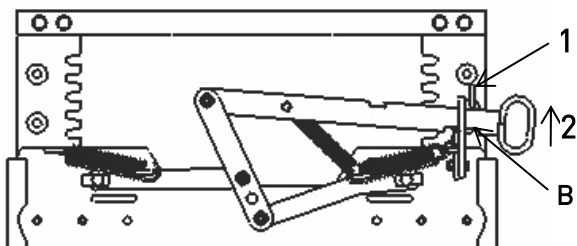

- 3 Unhook safety clip
- 4 Push hand lever forward in direction of travel until limit stop is reached (slot B is free)

↑ Direction of travel

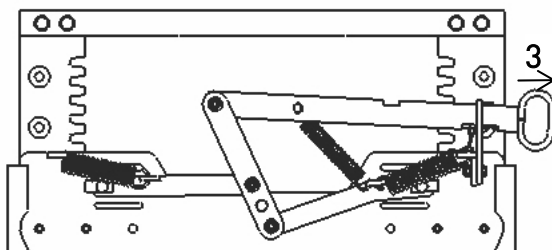

- 3 Pull hand lever against force of spring towards vehicle exterior side

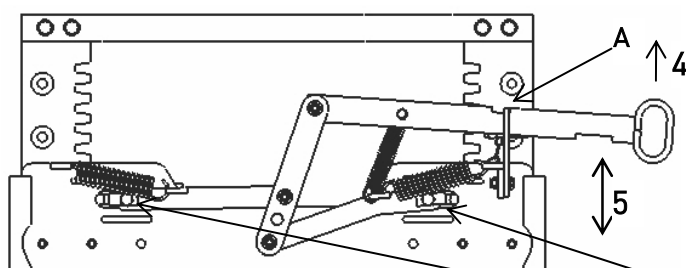

- 4 Slide slot A forward in the direction of travel into the lever guide
Release handbrake (remove steering wedge)
- 5 Start sliding procedure

View from below:
Locking wedges are fully retracted

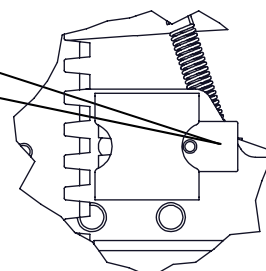

Locking the slider (manually operated)

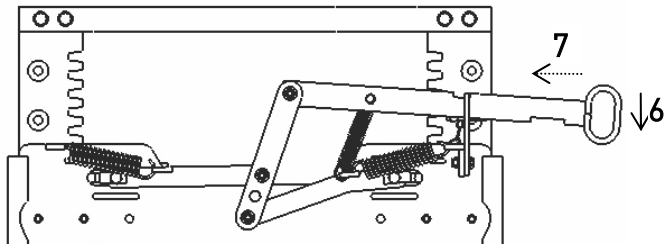

- 6 Press hand lever backwards in the direction of travel
- 7 The force of the spring pulls the lever toward the inside

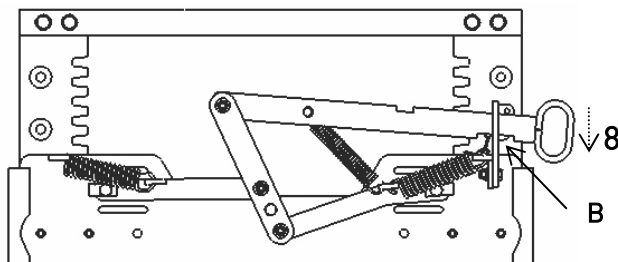

- 8 Slot B is pulled by the spring into the lever guide

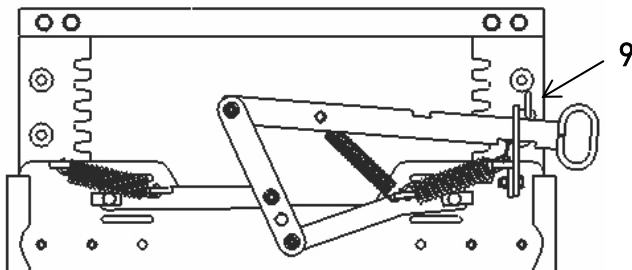

- 9 Hook the safety clip



Warning

If not properly locked, the safety clip cannot be hooked

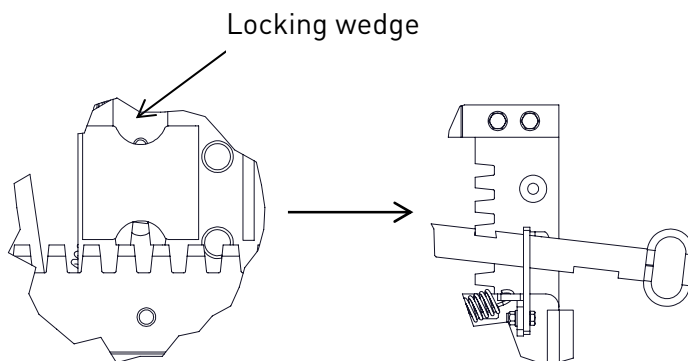

Properly locked?

- 1 Release handbrake.
- 2 Put into first gear and roll slowly forward approx. 2 m.
The locking wedges slide into the next available pair of teeth (with a short jerk).
- 3 Engage handbrake!
- 4 Hook safety clip!

Unlocking and locking the slider (pneumatically operated)

- The slider is unlocked and locked from the driver cab by means of an operating valve.



Warning
Pressing the button to release the sliding function (in the driver cab) may only be done if the vehicle is at a standstill! During the sliding procedure, the semi-trailer must be secured with wedges placed underneath it!

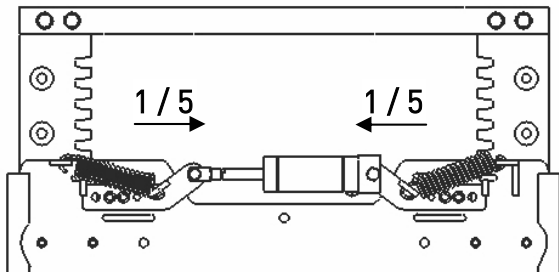

- 1 Press button in driver cab and hold **depressed**.
- 2 Release handbrake from tractor unit
- 3 Move the vehicle.
- 4 Pull the handbrake into the desired position.
- 5 Release the button.



Note: Inspecting the lock
After each sliding procedure, a visual check must be performed to ensure correct locking.

Locking complete (correct)

The indicator pointer (Z) must **completely** cover the indicator field (F)!

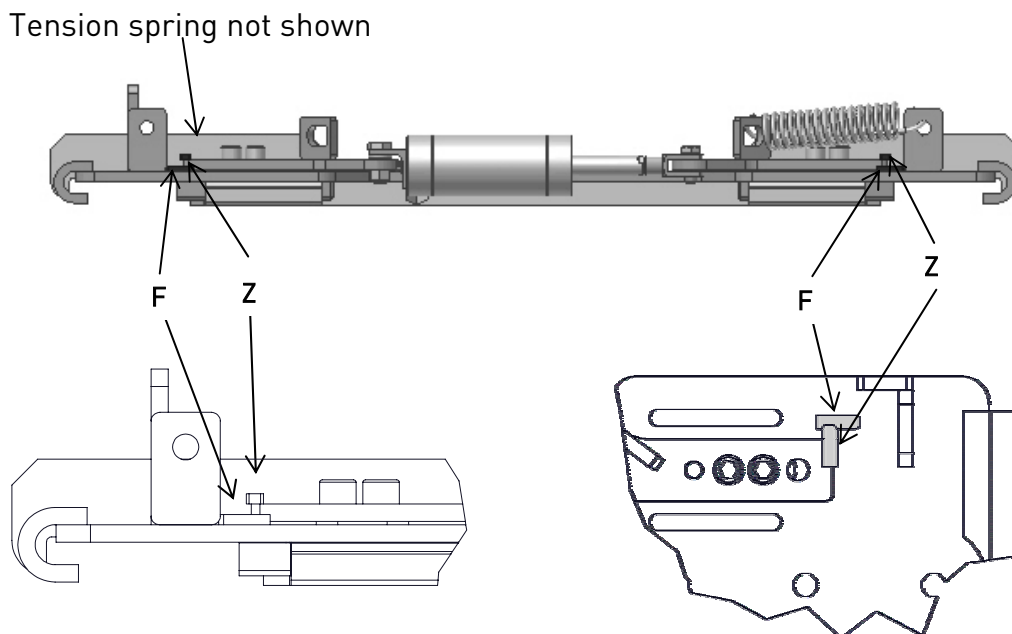

Locking incomplete

If the locking is incomplete, the indicator pointer (Z) does not cover the indicator field (F)!

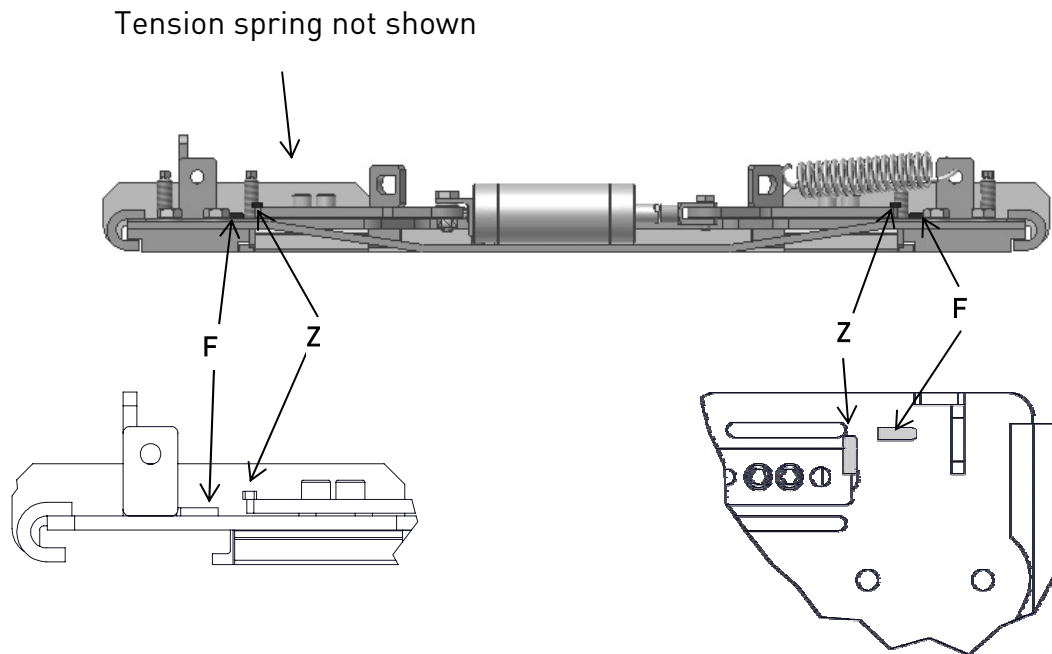

If the coverage is not complete:

- 1 Release handbrake.
- 2 Put into first gear and roll slowly **forward** approx. 2 m.
The locking wedges slip into the next available pair of teeth (with a brief jerk).
- 3 Engage handbrake.
- 4 Check for proper locking.

Manual conversion – pneumatically operated

- The conversion should only be performed by personnel specially trained for this.
- No disassembly of the slider from the vehicle auxiliary frame is required for the conversion.
- The following tools are required for the conversion:
 - Ratchet wrench with short extension (optionally, long extension)
 - Screw mounting kit, size 19
 - Box wrench, size 19, hexagon socket wrench, sizes 12 and 6
 - Open-jaw wrench, sizes 14 and 11, spring hook, hammer, round chisel

Disassembling the manual locking mechanism

- Before beginning, fix locking wedges and carriage so they cannot slide (risk of crushing).

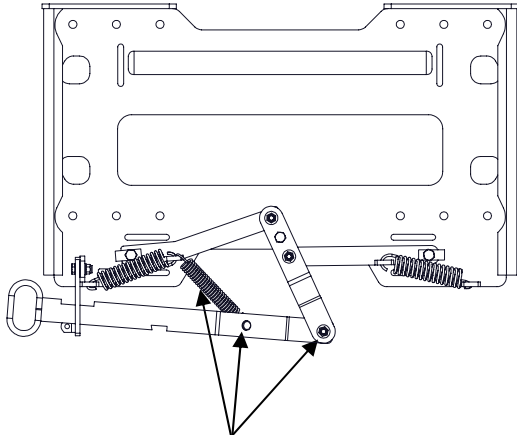

- 1 Release and remove screw
- 2 Unhook spring and remove with bolt

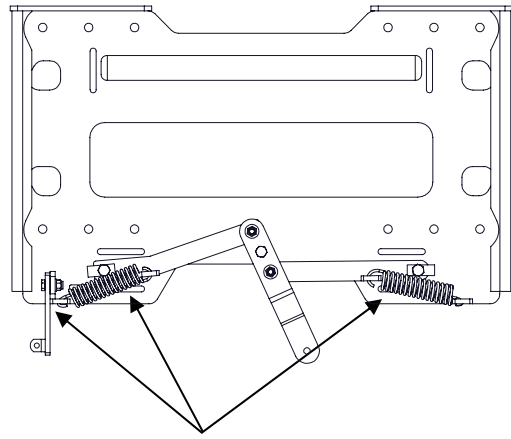

- 3 Dismantle lever support
- 4 Unhook springs (left and right) and remove

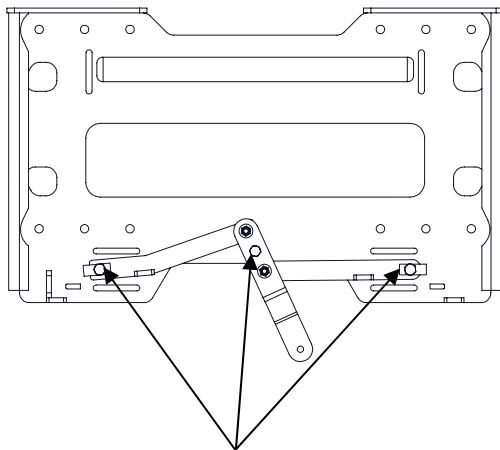

- 6 Release and remove screws
- 6 Remove mechanism
- 7 Remove sleeves (2x)

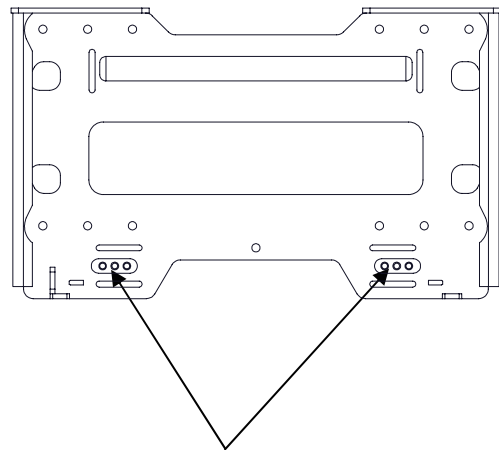

- Align the locking wedges so that the 3 drilled holes each are centred in relation to the guide (punching)

Assembling the pneumatically operated locking mechanism

Assembly of lug angle on housing lid of P-cylinder

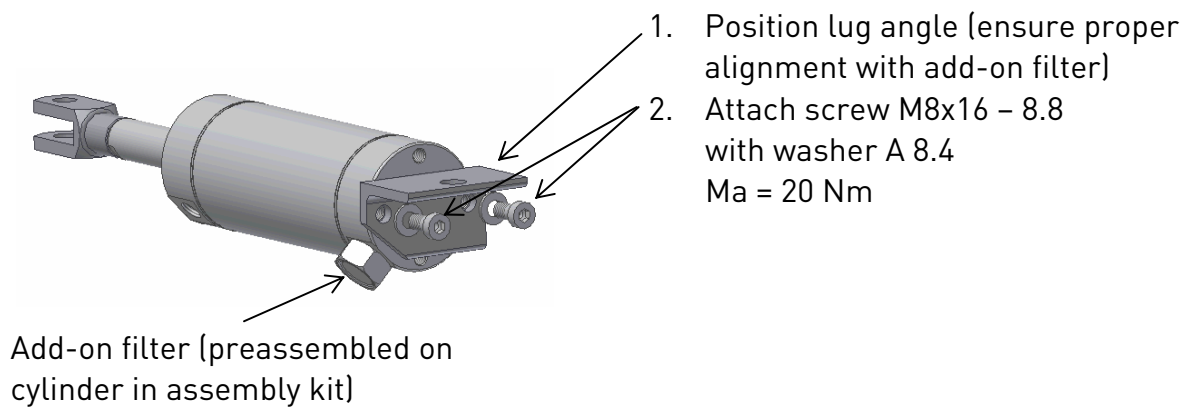

Mounting width on vehicles
780 – 900 mm

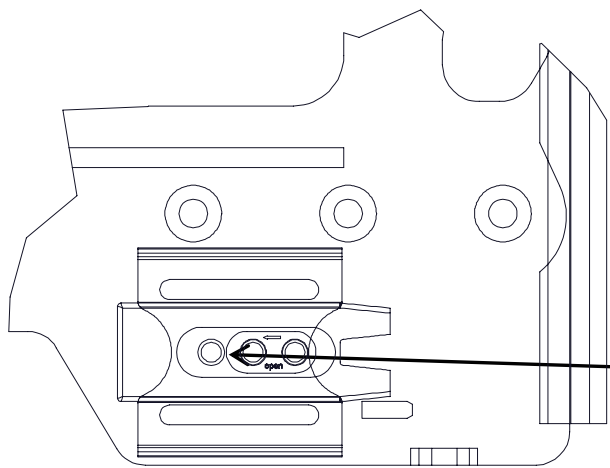

1 Position spacers (left and right),
Position for models 780 – 900 mm

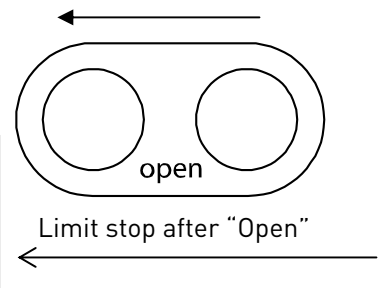

Mounting width on vehicles
900+ mm

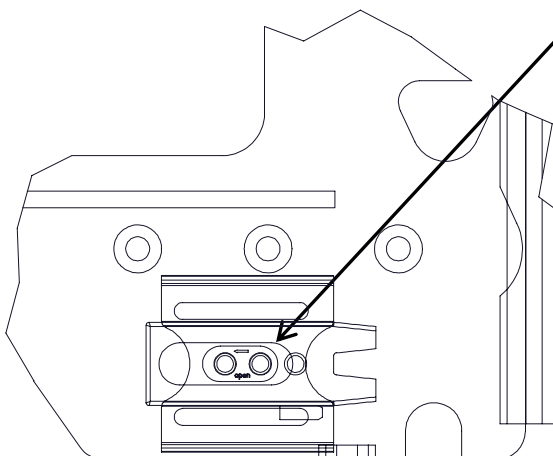

1 Position spacers (left and right),
Position for models 900+ mm

Arrow and "open", engraved on spacer, points on both sides in the direction of the slider centre (slider "opens")

**Mounting width on vehicles
780 – 900 mm**

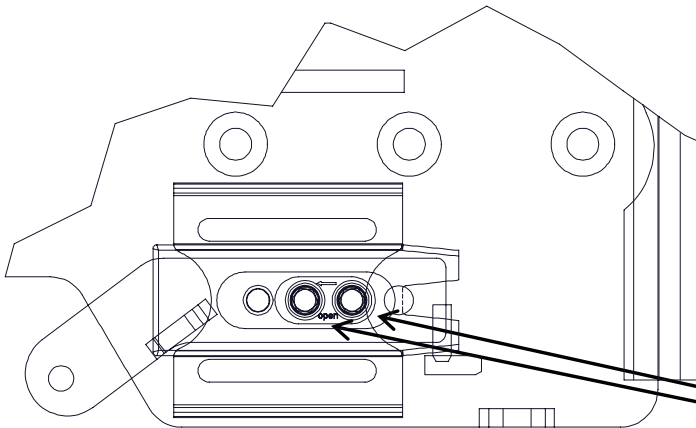

- 2 Position levers (left and right),
Position for models 780 – 900 mm
- 3 Screw in screw (2x per side),
Ma = 170 Nm ± 10 Nm

2 Models 780 – 900 mm:
Drilled holes 1 and 2

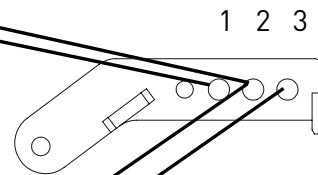

**Mounting width on vehicles
900+ mm**

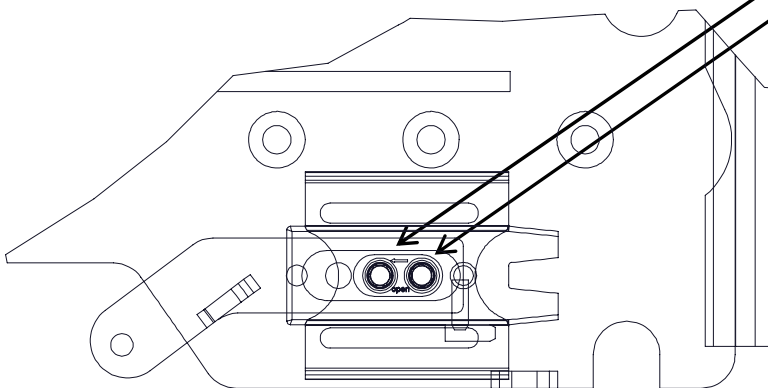

2 Models 900+ mm:
Drilled holes 2 and 3

- 2 Position levers (left and right),
Position for models 900+ mm
- 3 Screw in screw (2x per side),
Ma = 170 Nm

- For the attaching of the levers, the SAF-HOLLAND original screws included in the mounting kit are exclusively to be used.
- The screws should only be reused once (1x fully unscrewed and 1x fully screwed back in). Thereafter, these screws should be replaced with new ones.

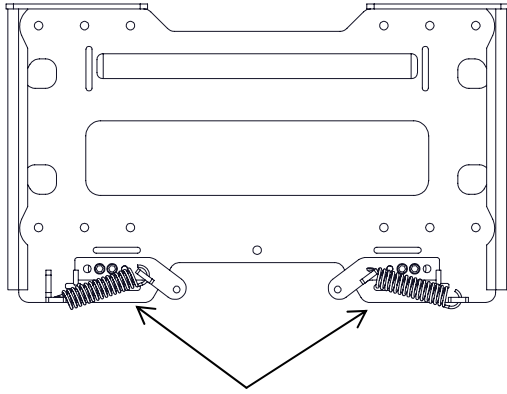

4 Mount tension springs (left and right)

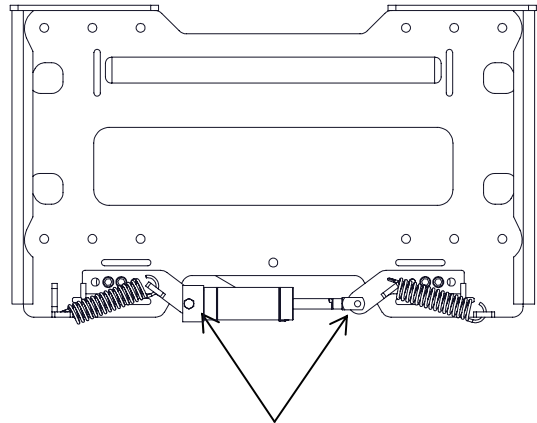

5 Mount cylinder (see detailed description)

5.1 Release contact spring (not shown, preassembled on cylinder in assembly kit) and connect it with forked head of piston rod

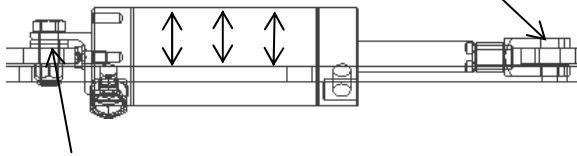

*Washers optionally 1x or 2x according to tolerance of the enclosed spare parts; align the cylinder vertically so that it is parallel to the carriage

5.2 Washer – A13 *

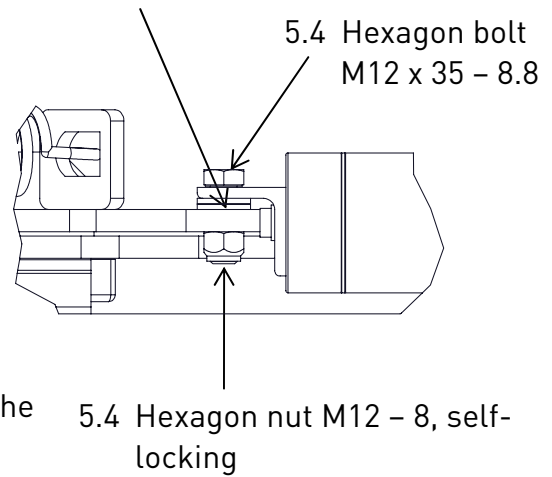

5.4 Hexagon bolt
M12 x 35 – 8.8

5.4 Hexagon nut M12 – 8, self-locking

Connecting to the vehicle pneumatics

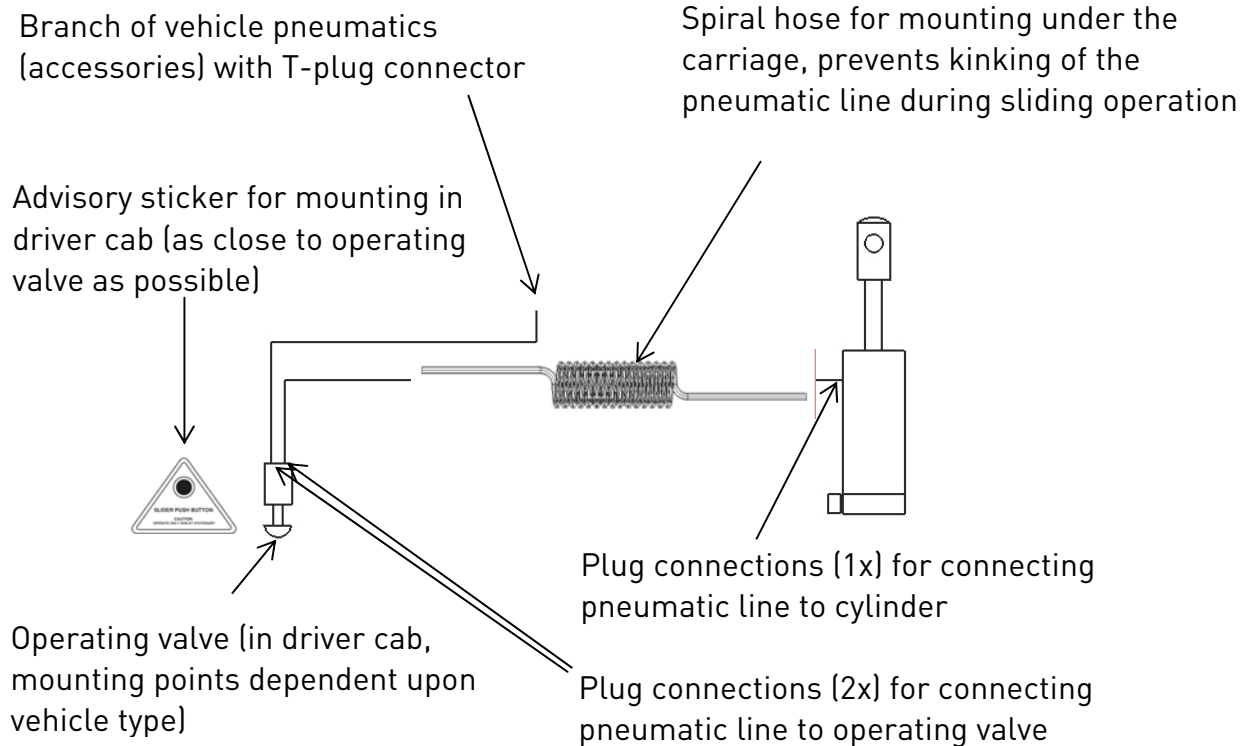

- The operating valve must be installed in the driver cab so that under any operating condition the possibility of unintended operation or damage can be excluded. The advisory sticker must be attached in a clearly visible position next to the valve.
- Attach the original SAF-HOLLAND advisory sticker in a clearly visible position next to the operating valve. Accidental covering of the sticker is to be avoided.
- All pneumatic parts may only be installed and used as intended for their described functions.
- During driving and sliding operation, it must be ensured that collisions with other vehicle parts cannot occur.
- The cylinder is designed for driving in an ambient temperature of $-40\text{ }^{\circ}\text{C}$. For technically flawless functioning of all pneumatic parts, an adequately dehumidified system air supply adapted for the ambient temperature must be available.
- For the mounting of the cylinder, only original SAF-HOLLAND screws with micro-encapsulation may be used.

Maintenance



Note

- The slider is a safety feature. The observance and careful performance of regular maintenance intervals is required to ensure technically flawless functioning over the entire service life.
- Before beginning maintenance work, secure the towing vehicle (handbrake, wedge placed underneath).

Before initial commissioning

Lubrication

- Before initial commissioning, the positions (D) through (F) should be treated with an oil spray conforming to ISO 22 (not available through SAF-HOLLAND). The use of grease of unspecified quality is not recommended for reasons of uptake and binding with street contaminants:

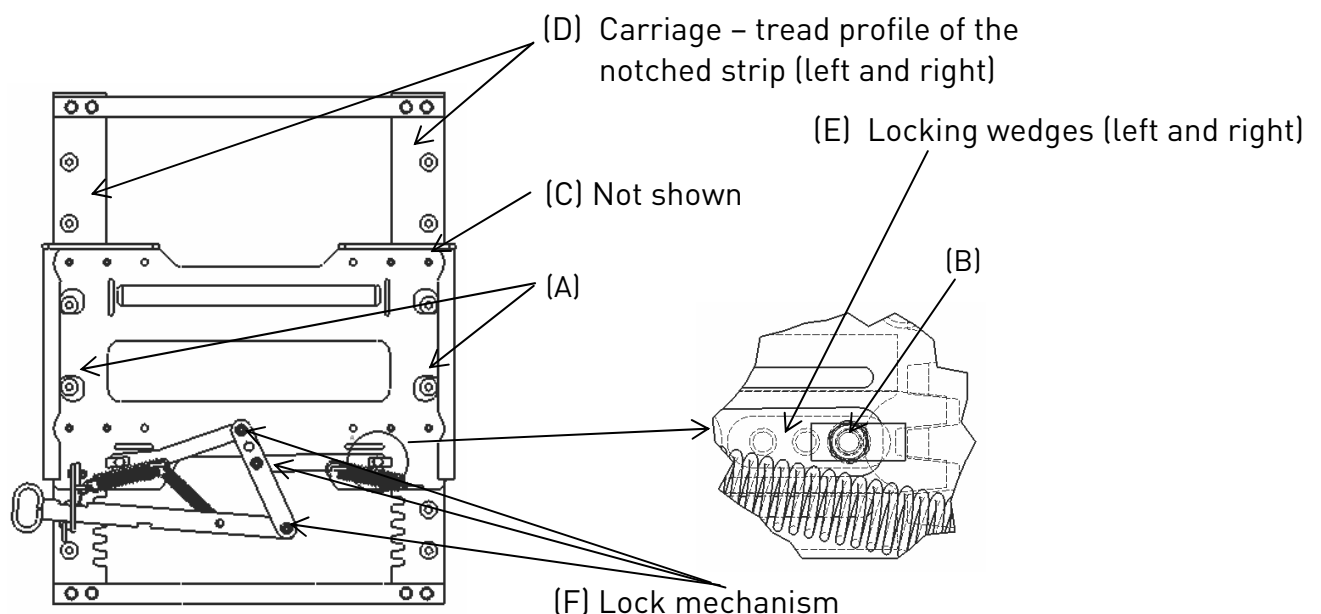

Inspection of the mountings

- The following mountings are to be inspected: (A) Screw connections between slider and frame (for Ma see page 4), (B) screws in locking wedges (Ma = 170 Nm) and (C) screws for mounting the SK-S 36.20 on the slider carriage (Ma = 270 Nm).

Maintenance intervals

Every 10,000 km

- (1) Uncouple the trailer and secure it (wedge placed underneath)
- (2) Clean fifth wheel and slider (use only commercially available cleaning agents specified for the unit)
- (3) Visual check for damage (especially connecting and moving parts, weld seams)
- (4) Check carriage guide measurements (see Fig. 1), a feeler gauge can be used for this
- (5) Apply cleaning oil ISO 22 to parts (A) through (F) (see page 33)

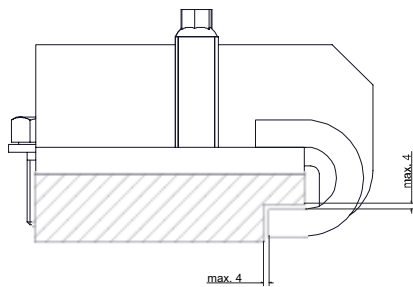

Fig. 1: Wear limits of the carriage guide (left and right)

Every 50,000 km

- (1) Uncouple the trailer and secure it (wedge placed underneath)
- (2) Visual check for damage (especially connecting and moving parts, weld seams)
- (3) Check carriage guide measurements (see Fig. 1)
- (4) Check for ease of movement during opening and closing (see manual chapter "Operation")
- (5) Check tension springs for proper action of blocking pieces (closing)
- (6) Check safety clip with chain for damage, tightness of fit
- (7) Check tightening torque for (A) through (C), see page 33
- (8) Check sliding play in the vehicle longitudinal direction between carriage and notched strips (for description see page 34, Fig. 2 through Fig. 5)
- (9) Apply cleaning oil ISO 22 to parts (A) through (F) (see page 33)

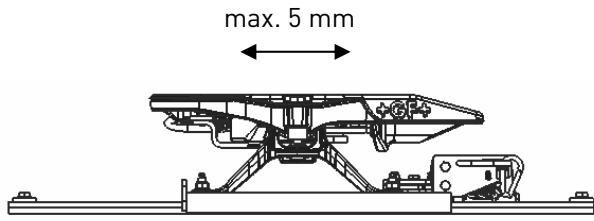

Fig. 2: Max. permitted longitudinal play

If longitudinal play is less than 5 mm, function OK.

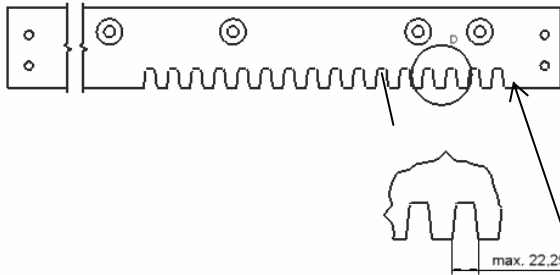

Fig. 3: Degree of wear on the teeth openings

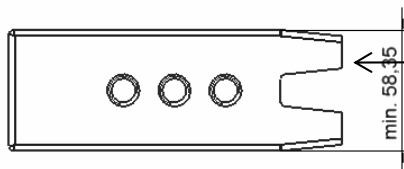

Fig. 4: Degree of wear on the blocking pieces

If longitudinal play is equal to or greater than 5 mm, the measurements of Fig. 3 to Fig. 5 must be checked, and the respective parts replaced if the limits are exceeded.

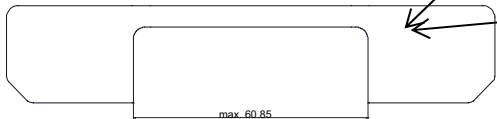

Fig. 5: Degree of wear on the locking wedge guides

If the width is greater than 60.85 mm, the carriage must be replaced in its entirety.

Repairs

(A) locking wedges

- The locking wedges can be exchanged in succession without disassembling the slider from the vehicle and without having to remove the retaining springs.

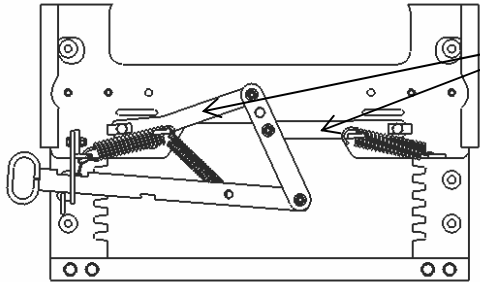

Note

Before starting work, secure the levers (left and right) so that they cannot twist (high spring tension, risk of injury)

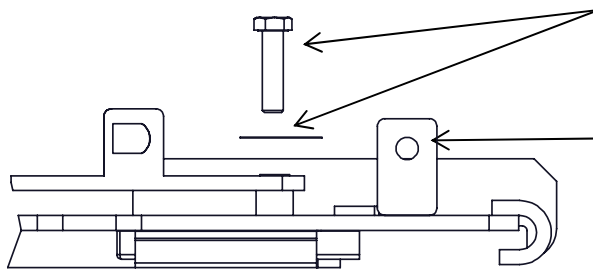

1 Bend safety flange 90°

2 Release M14 screw and remove it with safety flange

Tension spring not shown

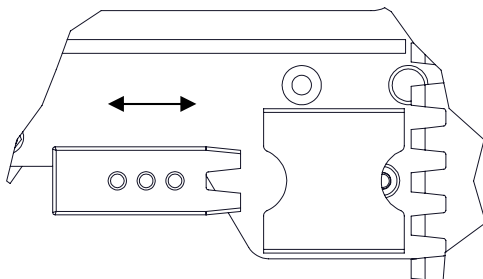

3 Push out locking wedges toward middle axle of vehicle (caution: risk of crushing injury)

4 Insert new locking wedges.

Proceed in the same manner with the other side. The assembly is done by reversing the sequence of steps.

- The replacement of the locking wedges can likewise be done as described in the chapter “Manual conversion – pneumatically operated” starting on page 9. The mounting of the disassembled parts is done by reversing the sequence of steps.

(B) Carriage, complete / guides for locking wedge

- If excessive wear occurs on the guides of the locking wedge, the slider must be removed from the vehicle and the carriage replaced.

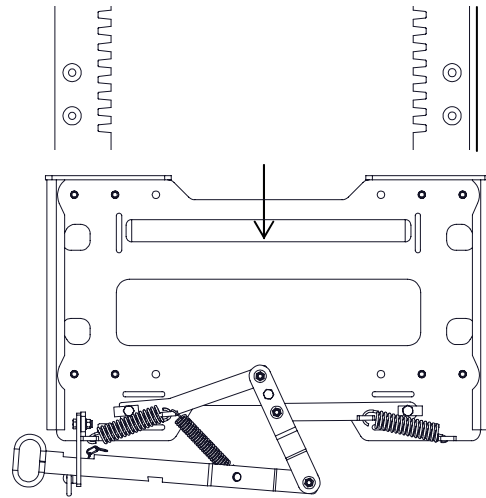
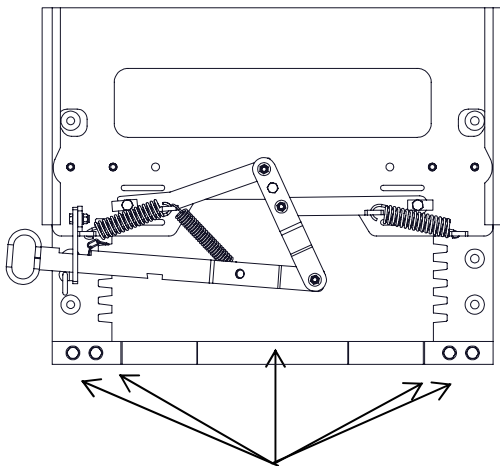

- 7 Separate slider from towing vehicle and attach securely to a secure support frame
- 8 Release screws (4x, M16) and remove with washer
- 9 Remove front limit stop

- 10 Push carriage forward in direction of travel
- 11 Fix carriage to a secure support frame
- 12 Component replacement as described in Chap. "Manual conversion – pneumatically operated" (from page 9). The assembly is performed by reversing the sequence of steps

Notes:



**Notruf
Emergency Hotline** +49 6095 301-247

**Kundendienst
Customer Service** +49 6095 301-602

**Aftermarket
Spare Parts** +49 6095 301-301

Fax +49 6095 301-259

service@safholland.de
www.safholland.com