

## SAF Trailer Axles – 5.75" Diameter (X-Series) Disc and Drum Brake and 5" Diameter Drum Brake Configurations

### Product Change Notice

Effective with shipments beginning September 12, 2011

TIS (Tire Inflation System) prep holes changed from (3) 1/4"-18 Threaded Holes to (1) 1/8"-27 Threaded Hole

To better serve our customer's tire inflation system requirements, we are making the following changes:

Prep holes in SAF axles will change from (3) 1/4"-18 threaded and plugged holes (**Fig. 1**) to (1) 1/8"-27 threaded and plugged hole (**Fig. 2**).

**Fig. 1 CURRENT**  
(3) 1/4"-18 Threaded and Plugged  
TIS Prep Holes

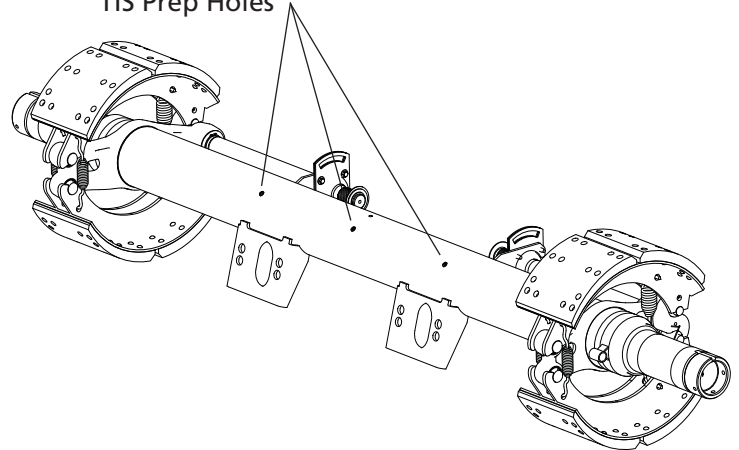

**Fig. 2 NEW - September 12, 2011**  
(1) 1/8"-27 Threaded and Plugged  
TIS Prep Hole

