

Wheel Outset and Spindle Capacity Configurations

Important Information

SAF® Trailer Axles with Wide-Base Single Offset Wheel Configurations

Wide base single tires are widely used and are gaining popularity in North America. When mounted on an axle designed for dual tires, the dimension across the axle from the outside of one tire to the outside of the opposite tire (out-to-out) will measure about 5" less when fitted with wide base single tires (**Figure 1**).

To maximize the wheel out-to-out dimension, wide base single tires require either a wider axle track or wheels that offset the tires in an outboard direction (**Figure 2**).

NOTE: A wheel that offsets the tire in an outward direction is referred to as being outset.

Dual wheels and zero offset wide base single wheels distribute the vehicle load optimally between inboard and outboard wheel bearings. An outset wheel results in the outboard wheel bearing experiencing a greater load than the inboard wheel bearing. SAF-HOLLAND® allows up to a two inch (2") outset on SAF® drum brake axles with parallel spindles and on SAF® INTEGRAL™ air disc brake axles with P89 spindles. (Refer to **Table 1**.)

Figure 1

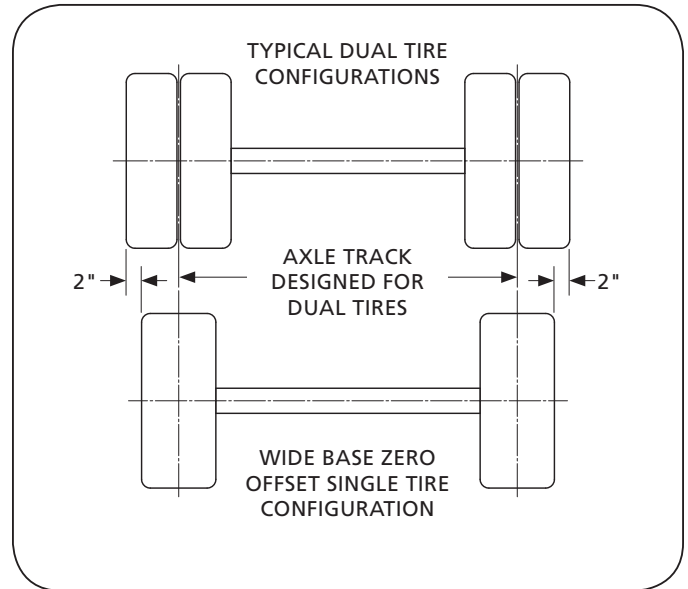
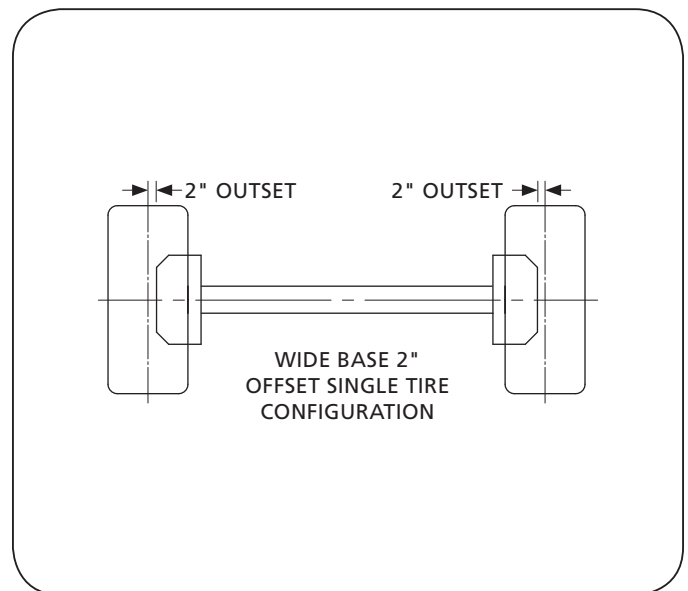

Figure 2





Offset wheels are not approved for SAF® tapered spindle drum brake axles or on SAF® INTEGRAL™ air disc brake axles with C88 Compact spindles.*

Due to the transfer of loading from one bearing to the other caused by outset wheel configurations, the GAWR per suspension model will vary on SAF® drum brake axles with parallel spindles and INTEGRAL™ disc brake axles with P89 spindles. Refer to **Table 1** for approved GAWR ratings for each SAF® suspension model.

Table 1

SAF® AXLE SPINDLE CAPACITY (GAWR in LBS.)					
		DRUM BRAKE SPINDLE		INTEGRAL™ DISC BRAKE SPINDLE	
SUSPENSION	OUTSET	TAPERED	PARALLEL	C88	P89
CB23U	Zero	23,000 lbs.	23,000 lbs.	NOT Available	NOT Available
	1" - 2"	NOT Approved	20,000 lbs.	NOT Available	NOT Available
CBX23 CBX23U	Zero	23,000 lbs.	23,000 lbs.	23,000 lbs.*	23,000 lbs.
	1" - 2"	NOT Approved	20,000 lbs.	NOT Approved	20,000 lbs.
CB25U	Zero	25,000 lbs.	25,000 lbs.	NOT Available	NOT Available
	1" - 2"	NOT Approved	20,000 lbs.	NOT Available	NOT Available
CBX25 CBX25U CBX25Y	Zero	25,000 lbs.	25,000 lbs.	25,000 lbs.*	25,000 lbs.
	1" - 2"	NOT Approved	20,000 lbs.	NOT Approved*	20,000 lbs.
CBX25/30 CBX25/30U CBX25/30Y	Zero	25,000 lbs.	25,000 lbs.	25,000 lbs.*	25,000 lbs.
	1" - 2"	NOT Approved	20,000 lbs.	NOT Approved	20,000 lbs.
CBX40	Zero	20,000 lbs.	20,000 lbs.	20,000 lbs.	20,000 lbs.
	1" - 2"	NOT Approved	17,000 lbs.	NOT Approved	17,000 lbs.
CBX46	Zero	23,000 lbs.	23,000 lbs.	NOT Approved	23,000 lbs.
	1" - 2"	NOT Approved	20,000 lbs.	NOT Approved	20,000 lbs.
CBX50	Zero	25,000 lbs.	25,000 lbs.	NOT Approved	25,000 lbs.
	1" - 2"	NOT Approved	20,000 lbs.	NOT Approved	20,000 lbs.
CBX69	Zero	23,000 lbs.	23,000 lbs.	23,000 lbs.*	23,000 lbs.
	1" - 2"	NOT Approved	20,000 lbs.	NOT Approved	20,000 lbs.
ULX40	Zero	20,000 lbs.	20,000 lbs.	20,000 lbs.	20,000 lbs.
	1" - 2"	NOT Approved	17,000 lbs.	NOT Approved	17,000 lbs.

* As of January 2014, the CBX23, CBX25, CBX25/30 and CBX69 production models are no longer available with the C88 spindle. Service components will continue to be available for pre-2014 units equipped with C88 spindles.