

## Maintenance Manual

### RLU SERIES

- RLU Series Underslung Suspensions for Fixed Frame Trailer Applications

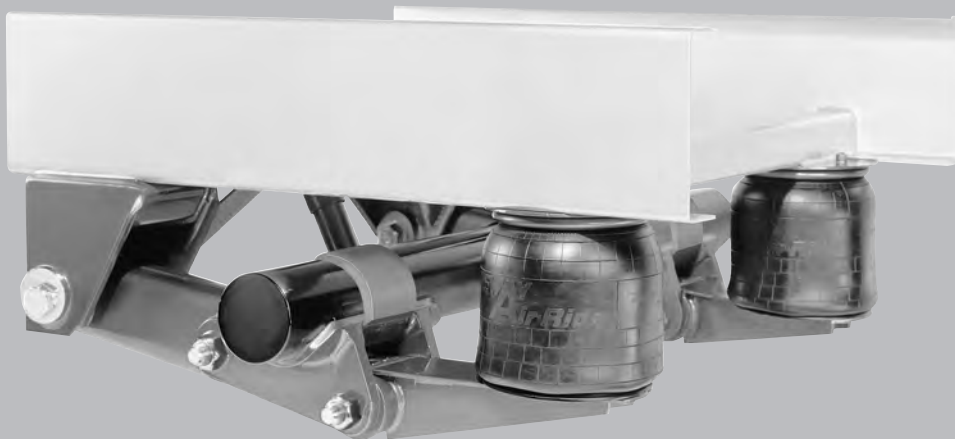

For Parts Information, refer to Parts List (Part No. XL-AR425).

Contents	Page
Introduction.....	2
Warranty.....	2
Notes, Cautions, and Warnings.....	2
Serial Number Tag Information.....	3
Model Identification.....	3
Model Nomenclature.....	3
How to Identify the Suspension Model.....	4
Service Repair Kits (see XL-AR425, page 5).....	5
Operation and Maintenance Instructions.....	6

Contents	Page
Pre-Operational Checklist.....	7
Torque Specifications.....	8
Standard Air Control System.....	9
Height Control Valve Information.....	10
Height Control Valve Inspection.....	11
Pressure Protection Valve.....	13
Axle Alignment.....	14
Component Replacement Instructions.....	15
Troubleshooting.....	22

## Introduction

This manual provides you information necessary for the care, maintenance, inspection, and safe operation of SAF-HOLLAND’s® RLU Series trailer air suspensions.

The SAF-HOLLAND Trailer Air Suspension is designed and engineered to provide trouble-free service. In the event of minor breakdown, such as a loss of air in the air springs, there are safety features designed into the suspension that will allow the vehicle to be driven CAUTIOUSLY at slow speed, to the nearest service facility.

This suspension uses air drawn from the tractor air system to pressurize the air springs. The height control valve regulates the air pressure required for varying loads and maintains the design ride height. This suspension can provide a cushioned ride throughout the load range, from empty to fully loaded.

The suspension also provides excellent side-to-side and axle-to-axle loading which helps equalize and control braking.

## Warranty

Refer to the complete warranty for the country in which the product will be used. A copy of the written warranty is included with the product as well as on the SAF-HOLLAND Web Site ([www.safholland.com](http://www.safholland.com))

It may also be ordered directly from the address shown on the back cover.

## Notes, Cautions, And Warnings

You must read and understand all of the safety procedures presented in this manual before starting any work on the suspension.

Proper tools must be used to perform the maintenance and repair procedures described in this manual. Many of these procedures require special tools.

Failure to use the proper equipment could result in personal injury and/or damage to the suspension.

### Safety glasses must be worn at all times when performing the procedures covered in this manual.

Throughout this manual, you will notice the terms “NOTE,” “IMPORTANT,” “CAUTION” and “WARNING” followed by important product information. So that you may better understand the manual, those terms are as follows:

**NOTE:** Includes additional information to enable accurate and easy performance of procedures.

**IMPORTANT:** Includes additional information that if not followed could lead to hindered product performance.

**CAUTION** Used without the safety alert symbol, indicates a potentially hazardous situation which, if not avoided, could result in property damage.

**⚠ CAUTION** Indicates a potentially hazardous situation which, if not avoided, could result in minor or moderate injury.

**⚠ WARNING** Indicates a potentially hazardous situation which, if not avoided, could result in death or serious injury.

## Model Identification

The RLU Series Suspension Serial Tag is normally located on the roadside frame bracket (**Figure 1**).

**NOTE:** This manual applies to the suspension series or the models listed on the front cover. However, we urge you to determine your specific model number, write that information below and refer to it when obtaining information or replacement parts.

**NOTE:** Refer to the serial number tag attached to the frame bracket for information.

Model Number \_\_\_\_\_ →

Parts List Number \_\_\_\_\_ →

Serial Number \_\_\_\_\_ →

In Service Date \_\_\_\_\_

**Figure 1** Serial Number Tag Location

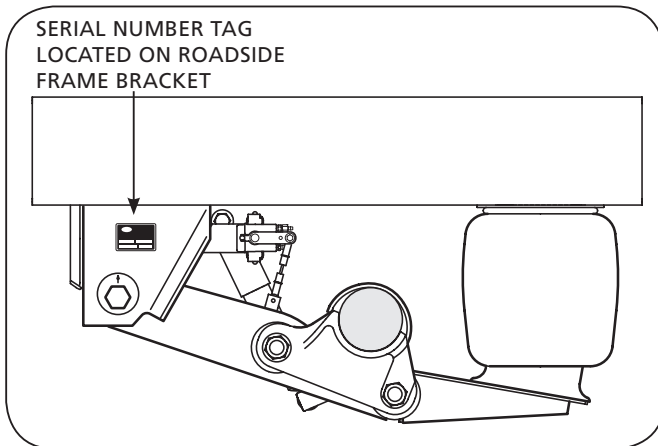

## Model Nomenclature

The sample tag shown below will help you interpret the information on the SAF-HOLLAND, USA, Inc. serial number tag. The model number is on the first line along with the suspension capacity. The second line contains the parts list number and serial number (**Figure 2**).

**Figure 2** Serial Number Tag

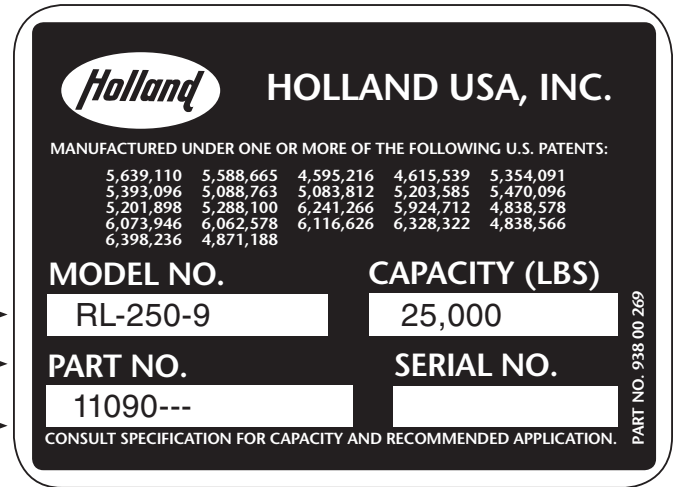

**NOTE:** Some models have an additional designation after the ride height.

Example: RLU-230-9-HMS (see below)

**RLU-250 - 9**

Ride Height  
 6" (152mm)  
 6.5" (165mm)  
 7" (179mm)  
 8" (203mm)  
 9" (229mm)  
 10" (254mm)  
 12" (305mm)

Axle Capacity and Suspension Series  
 22,500 RLU-228 Series  
 25,000 RLU-250 Series  
 30,000 RLU-300 Series

## Model Nomenclature *continued*

To correctly identify the model requiring replacement parts, check the serial tag for any special feature designations (in **bold** below, also **Figure 3**). Identify suspension characteristics by breaking down each part number as shown in the examples below:

### Example 1:

- RLU-228-9-3
- 228 = 22,500 lbs. axle capacity
  - 9 = 9" ride height
  - 3" = axle travel (up)

### Example 2:

- RLU-250-12-4
- 250 = 25,000 lbs. axle capacity
  - 12 = 12" ride height
  - 4" = axle travel (up)

## How to Identify the Suspension Model

When ordering replacement parts, it is important to identify the correct suspension model by noting any special feature designation. Refer to special feature designation at the end of the model number below the serial number tag on page 3.

If the serial number tag is missing, suspension model verification can be achieved by noting the characteristics of each suspension series.

**Identifying an RLU-228 Series:** The equalizing beam has a distinctive shape at the air spring mounting plate area at the rear of the beam (**Figure 3**).

**Identifying an RLU-250 Series:** Due to many variations within the RLU Series family, closer inspection may be required to determine which model you have. The RLU-250 standard suspension is illustrated in **Figure 3**. If closer examination is required, check the shock absorber part number, which will be located at the base of the shock to assist in determining the ride height.

**Identifying an RLU-300 Series:** Due to many variations and close resemblance to the RLU-250 Series suspension, the RLU-300 Series suspension requires closer examination by checking the shock absorber part number, which will be located at the base of the shock to assist in determining the ride height.

To correctly identify your specific model requiring replacement parts, proceed (1) by identifying the style of equalizing beam (**Figure 3**), and (2) by identifying the shock's mounting orientation and part number.

**IMPORTANT:** If you find you need further assistance with identifying your specific suspension model, reference XL-AR425, RLU Series - Parts List.

**Figure 3** Equalizing Beam Styles

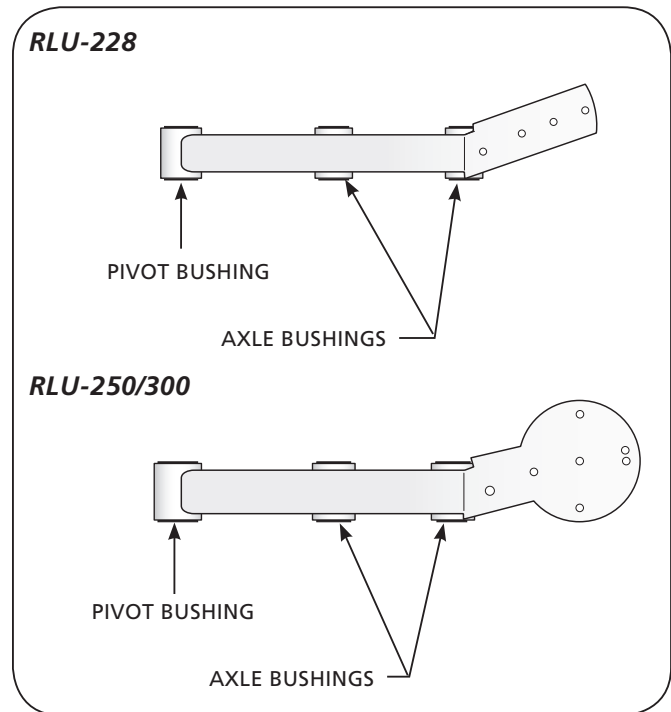

## Determining Ride Height

After the suspension model has been determined check the shock absorber part number (normally located on the dust shield). This will help you verify the ride height you have. Go to RLU Series Parts List Manual, XL-AR425, and using the shock part number, you can verify the ride height you have.

### RLU-228 Series:

Model RLU-228 (ARU-93), pages 8 and 9.  
 Model RLU-228 Current Production, pages 10 to 15.

### RLU-250 Series:

Model RLU-250 Standard, pages 16 and 17.  
 Model RLU-250 Frame Mount, pages 18 and 19.

### RLU-300 Series:

Model RLU-300 Standard, pages 20 and 21.

## Common Replacement Parts Come in Service Repair Kits (SRKs)

To simplify ordering the correct number of common replacement parts, Service Repair Kits were formed to offer you proper components having correct quantities, making maintenance easier by doing tasks correctly the first time.

The RLU Series suspension provides Service Repair Kits (SRK's) for the replacement of pivot/axle connections (**Figure 4**).

**IMPORTANT:** For easier field replacement of RLU Series frame brackets the EZ-Align (non-welded) style frame bracket **MUST** be used to replace a welded alignment style frame bracket. Kit includes all pivot connection components, except the pivot bushings.

**IMPORTANT:** Check the head of the pivot bolt. Bolts have **1051**, **1055** or **1069** on the bolt head, reducing the number of possible kits associated with your type of bolt (refer to Pivot and Axle Connection Service Repair Kit Chart on page 5 of XL-AR425).

**Figure 4** Pivot and Axle Connections

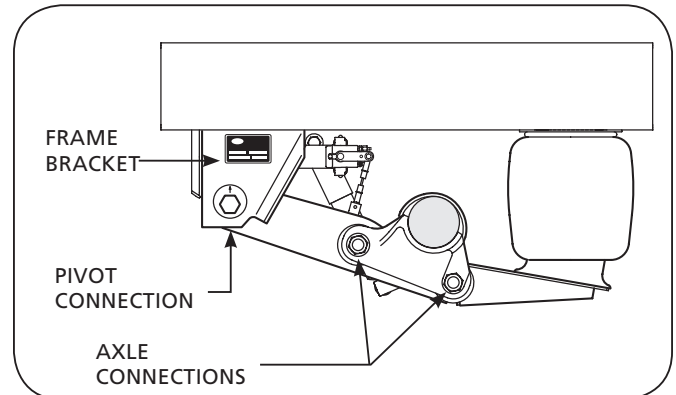

## Pivot and Axle Connection Rubber Bushings

**IMPORTANT:** When replacing the rubber bushings at these connections be sure the proper SAF-HOLLAND SRK (Service Repair Kit) is used as they contain all necessary parts to service one axle. It may be advantageous to service both pivot and axle connections at the same time. (Refer to Pivot and Axle Connection Service Repair Kit Chart on page 5 of XL-AR425.)

**NOTE:** The SAF-HOLLAND Bushing Service Tool, Part No. 505 44 012 (**FIGURE 5**), is available to ease removal and replacement of bushings. Contact your SAF-HOLLAND distributor or Parts List for details.

**IMPORTANT:** It is recommended that the vehicle be unloaded before beginning service procedures.

**Figure 5** Bushing Service Tool

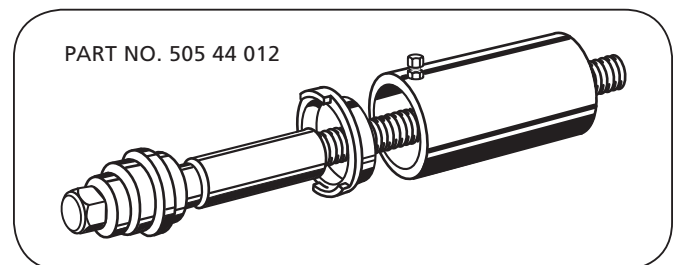

The RLU Series Trailer Air Suspension models covered in this manual are controlled by a single height control valve (standard air control system). When properly adjusted, the height control valve will maintain a constant ride height by controlling the air pressure in the air springs to support the load being carried.

The trailer air pressure must be maintained in excess of 75 psig (5.2 bars) before operation. 75 psig (5.2 bars) is required to open the Air Pressure Protection Valve, which maintains safe air brake pressure in the event of an air loss in the suspension system.

In the event that an air loss should occur, it is recommended the Height Control Valve Linkage be disconnected to assure all air springs are completely deflated. The trailer can be temporarily operated on the air spring's internal rubber bumpers, which carry the load if there is tire clearance. In the event of inadequate air pressure, operate the trailer CAUTIOUSLY, at a slow speed, to the nearest place of repair. To deflate the air suspension, refer to page 15, step 2.

Before transporting the vehicle to a service center, check tire clearances. DO NOT operate the vehicle if any tire(s) is rubbing the vehicle.

**⚠ WARNING** Tire clearance must be maintained between tires and the nearest point of contact on the suspension or vehicle. Fire or loss of vehicle control could occur if clearances are not maintained which, if not avoided, could result in death or serious injury.

## IMPORTANT

### ROUTINE MAINTENANCE AND DAILY INSPECTION

#### Daily Inspection

Daily or before each trip, check the suspension to be sure it is fully operational. Visually inspect air springs for sufficient and equal pressure and to see that suspension is set at proper ride height. Refer to page 10 for ride height measurement and re-setting instructions. Service as necessary.

#### Initial 5,000 Mile (8,000 km) Service Inspection

1. Suspension ride height (underside of frame to centerline of axle) **MUST BE WITHIN  $\pm 1/4$ " OF RECOMMENDED DESIGN HEIGHT.** Refer to page 10 for instructions on measuring ride height.

#### CAUTION

An improperly set ride height could result in suspension component damage and/or poor vehicle ride performance.

2. After initial 5,000 miles (8,000 km) of service, inspect bolts and nuts at the pivot and axle connections to assure they are properly torqued. Check all other nuts and bolts for proper torque. Re-torque as necessary thereafter.
3. With vehicle on level surface and air pressure in excess of 75 psig (5.2 bars), all air springs should be of sufficient and equal firmness.

**NOTE:** Check all air control system fittings for air leaks, by applying a soapy water solution and checking for bubbles at all air connections and fittings.

### Routine Physical Inspections

Every 100,000 Miles\* (160,000 km) or 1 year, whichever comes first.

When servicing vehicle brake system, inspect suspension components per pre-operational checklist on page 7. Also check all other suspension components for any sign of damage, looseness, torque loss, wear or cracks. Repair, tighten or replace damaged part(s) to prevent equipment breakdown.

### Visual Inspection Procedure

**\*IMPORTANT:** A schedule for physical and visual inspections should be established by the operator based on severity of operation or damage to the vehicle could occur.

**IMPORTANT:** During each pre-trip and safety inspection of the vehicle, a visual inspection of the suspension should be done or damage to the vehicle could occur.

Visually check for:

- **Bolt movement** – loose dirt, rust or metal wear around bolt head and nut.
- **Air springs** – clearances, wear damage, and proper inflation.
- **Shock absorbers** – leaking or damaged.
- **Cracked parts or welds.**

**Prior to placing unit in service, check the following items:**



Failure to chock tires prior to beginning maintenance could allow vehicle rollaway which, if not avoided, could result in death or serious injury.

1. Build air pressure above 75 psig (5.2 bars). With the vehicle shut off, check the system for air leaks.
2. With the vehicle on a level surface and air supply pressure in excess of 75 psig (5.2 bars), check the air springs for equal firmness.
3. Check the shock absorbers for proper installation. The 3/4" shock absorber nuts must be torqued to specifications (**Table 1 Torque Chart**, page 8).
4. The 1/2" and 3/4" air spring mounting nuts must be torqued to specifications (**Table 1 Torque Chart**, page 8).
5. Check for 1" (25mm) minimum clearance around the air springs with vehicle loaded (**Figure 6**).
6. The 1 1/8" axle connection nuts must be torqued to specifications (**Table 1 Torque Chart**, page 8).
7. The suspension ride height should be within  $\pm 1/8$ " of the recommended design height. Refer to "Height Control Valve Adjustment" on page 10 for the proper setting.

8. Visually check the welding of all axle adapters to axles — 1/2" (13mm) minimum fillet weld required (**Figure 6**).
9. Visually check the welding of all curbside fixed alignment pivot connections on both sides of frame bracket (**Figure 8**, page 8).  
If welds are not present, weld the alignment plates in-board and out-board of the frame bracket per SAF-HOLLAND NS-65-07-CI specification — consult SAF-HOLLAND publication XL-AR353-01 — and as illustrated in **Figure 8**, on page 8. Weld all around with 5/16" (8mm) weld.

**IMPORTANT:** The EZ-Align design maintains proper alignment under correct torque without welding; DO NOT weld alignment blocks (**Figure 7**, page 8).

**NOTE:** EZ-Align pivot connections (non-welded) are on roadside and fixed alignment pivot connections (welded) are on curbside. However, some manufacturers use EZ-Align on both sides. Refer to page 14 for "EZ-Align (Non-welded) Connection Axle Alignment" procedure.

10. A 1 1/8" pivot nut must be torqued to specifications (**Table 2 Pivot Bolt Torque Chart**, page 8).

*continued*

**Figure 6**

**RLU Series Suspension Pre-Operational Checklist Items**

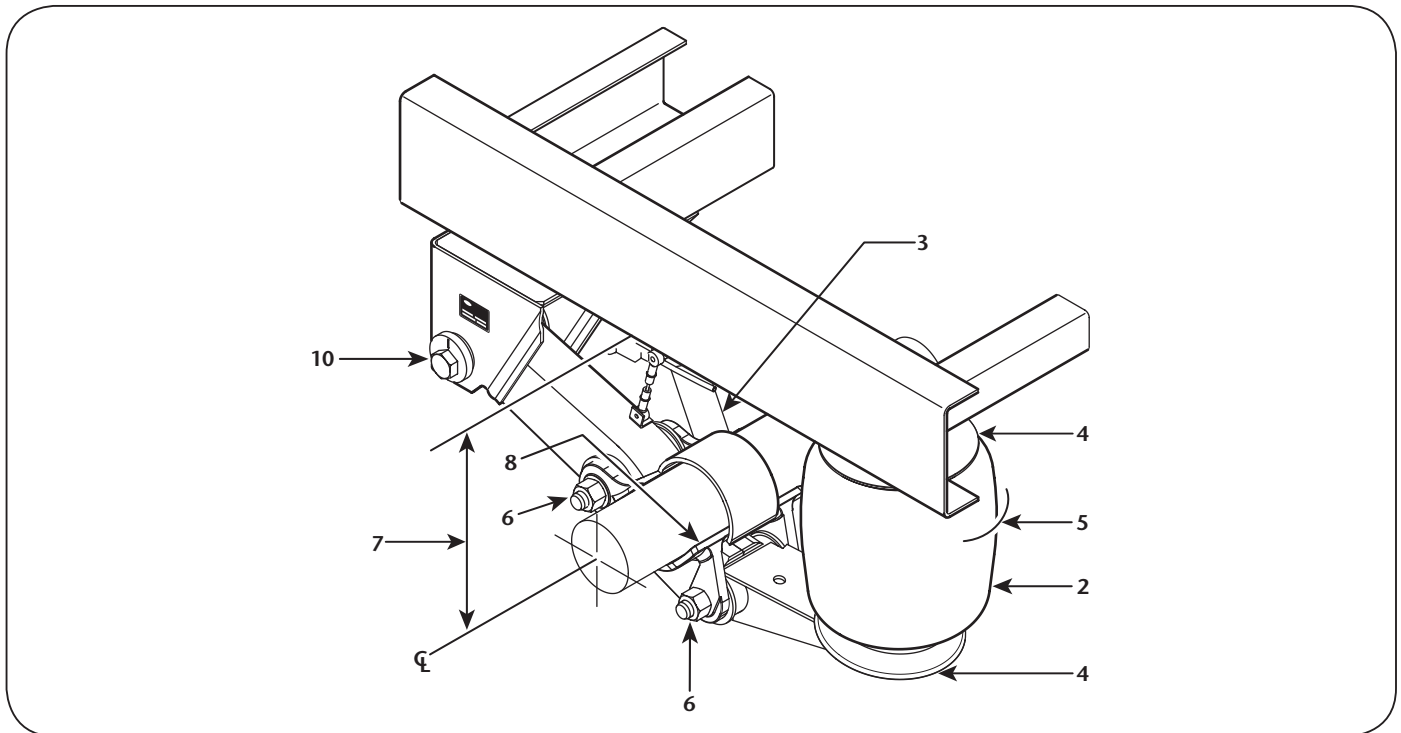

**IMPORTANT:** Torque requirements listed are for clean and lubricated threads. Use of special lubricants with friction modifiers, such as Anti-Seize or Never-Seize, without written approval from SAF-HOLLAND Engineering will void warranty and could lead to premature bolt failure or other component issues.

**Table 1** **Torque Chart**

Size	Torque Ft. Lbs.	Torque NM
3/4"	150	203
1 1/8"	600	814
1/2" - Air Spring	30 - 40	41 - 54
3/4" - Air Spring	40 - 45	54 - 61
7/8" - U-bolt	300	407

Bolt Size	Socket Size
1/2"	3/4"
3/4"	1 1/8"
1 1/8"	1 11/16" *
7/8"	1 5/16"

\*Deep Well Socket

**Table 2** **Torque Decal**

TRAILER AIR SUSPENSION TORQUE SPECIFICATIONS

Fastener Size	Pivot and Axle Connection	U-Bolt	Shock	Air Spring	
	1-1/8"	7/8"	3/4"	1/2"	3/4"
Torque Ft-Lbs. (N*m)	600 (814)	300 (407)	150 (200)	30-40 (41-54)	40-45 (54-61)

All torque specifications are ± 5%.  
Torques specified are for clean, lubricated threads.  
Always apply torque to nut, if possible.

**REQUIRED RE-TORQUING SCHEDULE:**

- All fasteners after first three (3) months or 5,000 miles.
- At every routine preventative maintenance.
- At every brake relining.

XL-AR355-02 Rev E  
 www.safholland.us  
 Copyright © 2018 • SAF-HOLLAND, Inc.

**Figure 7** *EZ-Align (Non-welded) Axle Alignment*

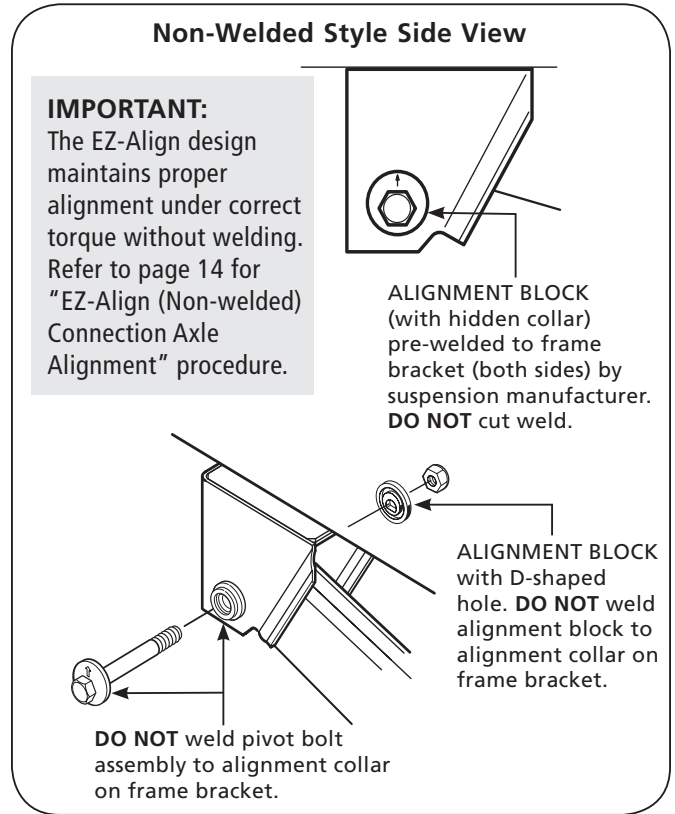

**Figure 8** *Welded Adjustable Axle Alignment*

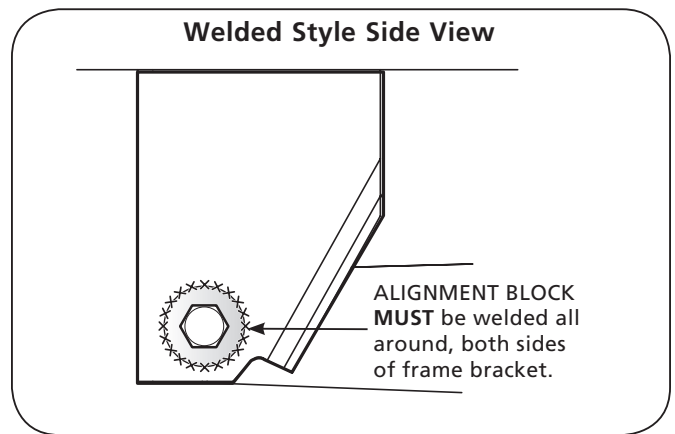



The Air Control System (**Figure 9**) depicts a standard RLU Series tandem piping diagram.

The air control system of the RLU Series suspension uses air drawn from the tractor air system to pressurize the suspension's air springs. The suspension, working with the air control system, provides optimum suspension performance only when all air control system components are installed and operating properly.

The height control valve regulates the air pressure required for varying capacities of load. It is critical to make sure the height control valve is set at the proper suspension ride height (**Figure 11**, page 10). Refer to pages 10-12 for height control valve detail.

A pressure protection valve is attached to the air reservoir and must be used to maintain proper air pressure. Refer to page 13 for maintenance.

**IMPORTANT:** Air pressure protection valve maintains safe brake pressure. Approximately 75 psig (5.2 bars) opens valve, 65 psig (4.5 bars) closes valve (**Figure 9**).

**Figure 9**

**Air Control System**

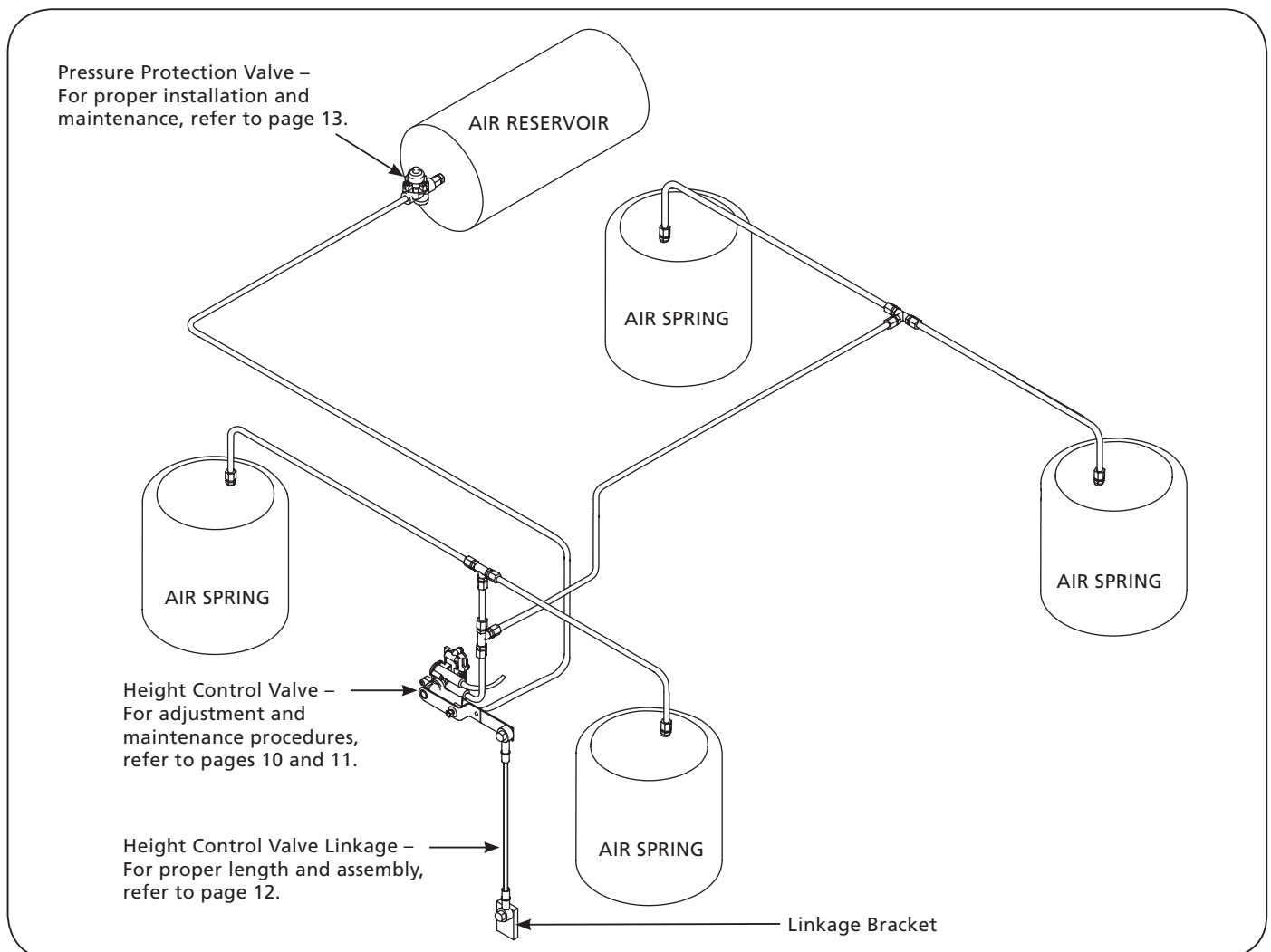

## Adjustment Procedure for a One HCV System

**⚠ WARNING** Failure to properly support suspension during maintenance may allow suspension to fall which, if not avoided, could result in death or serious injury.

1. Prior to adjustment, the vehicle must be in an unladen condition on a level floor and supported on a kingpin stand or coupled to a tractor (**Figure 10**). If supported with a kingpin stand, front of trailer must be supported at operating height.

**Figure 10 Trailer Supported at Fifth Wheel Height**

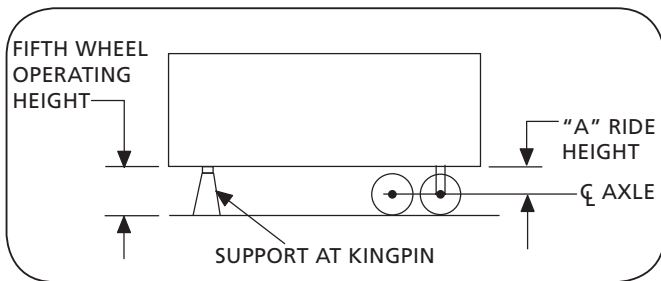

2. Disconnect height control valve linkage to lower mounting bracket (**Figure 14**, page 12), move control arm to "up" (45°) position and hold for 10-15 seconds to raise vehicle (**Figure 12**). Return control arm to center (neutral) position (**Figure 13**, page 11).

**Figure 11 Obtaining Proper Ride Height**

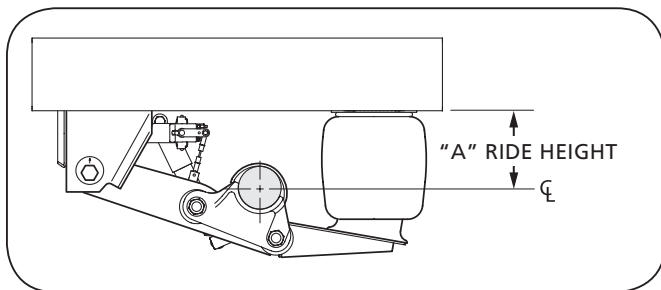

**⚠ WARNING** Failure to properly support suspension during maintenance may allow suspension to fall which, if not avoided, could result in death or serious injury.

**NOTE:** It may be necessary to shim jack stands to achieve proper ride height.

3. Place jack stands between the trailer frame and ground. Place one stand on each side at proper ride height (**Figure 11**). With jack stands in position, move control arm to 45° "down" position and lower vehicle and deflate all air from air springs and system. Return control arm to center (neutral) position and recheck for proper "A" ride height (**Figure 11**).

**Figure 12 Height Control Valve**

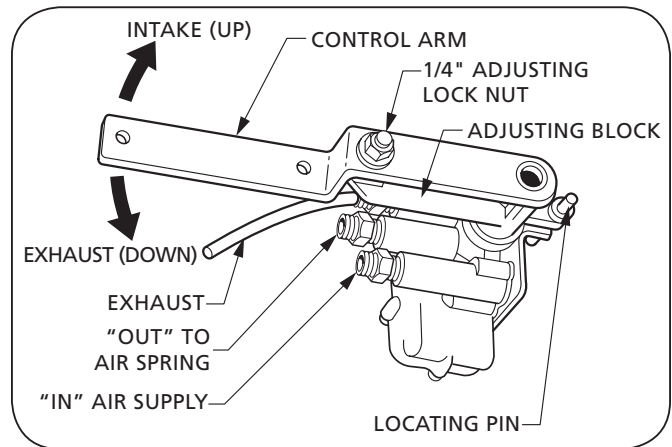

4. With the control arm in the center (neutral) position (**Figure 13**, page 11), insert locating pin into the adjusting block and bracket on the height control valve (**Figure 12**). Loosen the 1/4" adjusting lock nut located on the adjusting block (**Figure 12**). This will allow the control arm to move up and down approximately 1" (25mm).
5. Reconnect the lower linkage, and torque to 30-40 in. lbs. (3.75-5 Nm).
6. Retighten the 1/4" lock nut at the adjusting block to 30-40 in. lbs. (3.75-5 Nm).
7. Remove locating pin inserted in Step 4, then raise vehicle to remove the jack stands.

**NOTE:** The height control valve may be used as an improvised jack by disconnecting the linkage at the lower bracket. Move control arm 45° to an "up" position to raise vehicle and remove jack stands. Move control arm 45° to "down" position, completely exhausting system, then reconnect lower linkage, and torque to 30-40 in. lbs. (3.75-5 Nm). The suspension system will return to and maintain the proper ride height.

## Height Control Valve Inspection

**IMPORTANT:** DO NOT grease height control valve.

1. Visually inspect the valve and linkage on a regular basis for proper clearance, operation and adjustment.
2. Dirt or foreign particles in the air line may harm the internal workings of the valve. Even though it contains a protective filter to eliminate foreign matter, normal air brake system maintenance should be practiced.
3. Drain moisture from air tank periodically. In severe cold weather an air dryer and/or an alcohol evaporator is recommended to avoid valve freezing and damage.

## Height Control Valve Performance Check

**IMPORTANT:** Proper inspection can eliminate unnecessary replacement of height control valve.

1. Apply air system pressure in excess of 75 psig (5.2 bars).
2. Disconnect lower connection of the link assembly from mounting bracket (**Figure 14**, page 12).
3. Move control arm up to 45° for 10-15 seconds – air should flow to air spring(s) (**Figure 13**).
4. Move control arm to center (neutral) position – valve should shut off air flow (**Figure 13**).
5. Move control arm down 45° for 10-15 seconds – air should exhaust (**Figure 13**).
6. Move control arm to center (neutral) position – valve should shut off air flow.
7. Valve is good if performance is as noted.

**NOTE:** If the valve does not perform correctly, replace the valve.

8. Reconnect lower link assembly to mounting bracket and torque to 30-40 in. lbs. (3.75-5 Nm).

**IMPORTANT:** If 75 psig (5.2 bars) air system pressure cannot be achieved, check pressure protection valve and vehicle air compressor to see if they are operating properly. Also check the air lines for obstructions caused by dirt particles, foreign debris, ice, etc.

**Figure 13** Height Control Valve Performance Check

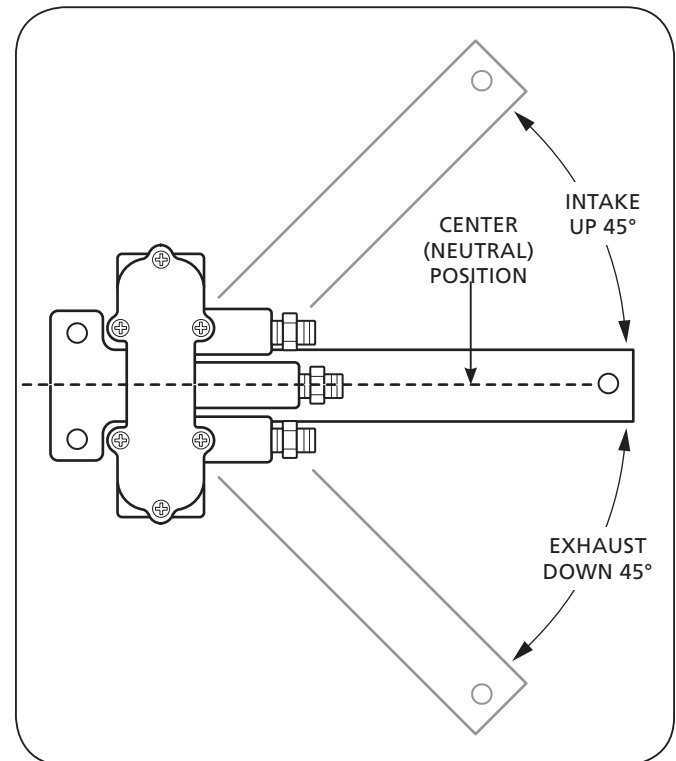

*continued*

## Check Height Control Valve Linkage for Proper Length and Assembly

1. With suspension set at proper ride height, determine length of link assembly required ("A" Dim.) (**Figure 15**). This can be achieved by measuring the distance from center line of height control valve arm hole to center line of lower connection bracket hole (**Figure 14**).

**IMPORTANT:** "A" measurement must be taken with suspension set at proper ride height (refer to **Figure 11**, page 10).

2. Determine length of rod required ("B" Dim.) by subtracting 1 3/8" (35mm) from "A" Dim. (**Figure 15**).

Example:

13 3/4" (349mm) "A" Dim. minus  
1 3/8" (35mm) = 12 3/8" (314mm)  
"B" Dim. is the length of the Rod required.

3. If new rod link is required, cut rod to length required; remove any sharp edges that may cause damage to the rubber link ends during assembly.
4. Assemble clamps, link ends and rods as shown (**Figure 15**). Insert rod into link end equal distance both ends, observing the minimum and maximum tolerance. Be certain the link ends are aligned to each other (**Figure 15**).
5. With link ends properly aligned and link assembly at required length, tighten clamps.
6. Install link assembly.

**IMPORTANT:** 5/16" washers **MUST** be inserted between nut and control arm or axle tab bracket, 5/16" washer between bolt head and rubber link. Torque to 30-40 in. lbs. (3.75-5 Nm) (**Figure 16**).

**Figure 14**

**Linkage Length**

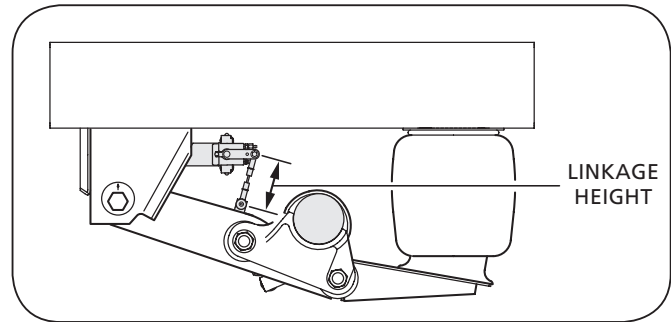

**Figure 15**

**Determine Length Of Link Assembly**

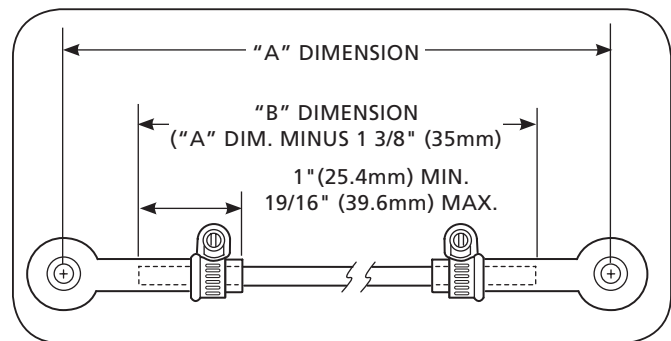

**Figure 16**

**Link End Assembly**

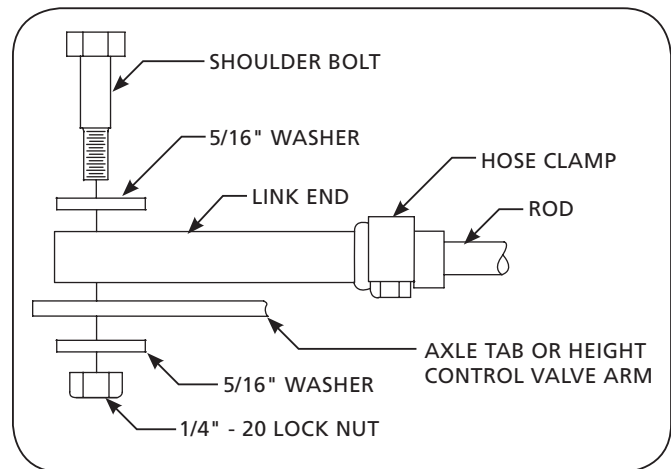

## Proper Installation

The new Air Pressure Protection Valve (PPV) (**Figure 17A**) should be installed so that the air supplied from the Air Reservoir enters the port marked "IN" on the PPV. If the Optional valve is used (**Figure 17B**), the arrows on the bottom of the valve should point away from the Air Reservoir towards the air suspension, while making sure the Cap is in the upright (TOP) position.

Install air lines to the air suspension and support lines where necessary (**Figure 9**, page 9), using clip supports, grommets and bulk head fittings. When installing pressure protection valve (PPV), use a drop of oil or loctite to lubricate threaded connections. **DO NOT USE** a pipe compound or teflon tape as they could clog valve. After PPV has been installed, pressurize air system with a constant supply of air in excess of 75 psig (5.2 bars), and check all connections for air leaks (**Figure 9**, page 9).

## Periodic Maintenance

**IMPORTANT:** Air pressure protection valves maintain safe brake pressure; **only** optional valve (905 54 107) cleans air by using a removable filter. Set at factory, approximately 75 psig (5.2 bars) opens the valve and 65 psig (4.5 bars) closes valve. (Attach PPV onto air reservoir — refer to **Figure 9**, page 9).

Drain all moisture from the Air Reservoir at regular intervals. Check the PPV for proper air flow. If optional PPV is used replace the filter every 3 months or when the air flow is reduced (**Figure 17B**).

The PPV must be checked for proper operation during each brake system inspection. The purpose of the valve is to maintain at least brake operating pressure in event of a serious air leak in the suspension system.

To test the PPV, charge the air system to 90+ psig and disconnect air line supply from downstream (suspension) side of PPV. Air should stop flowing through the PPV before the spring brakes begin to apply or before the tank pressure is reached.

**IMPORTANT:** If air does not stop flowing, replace the pressure protection valve.

**Figure 17A**

**Pressure Protection Valve**

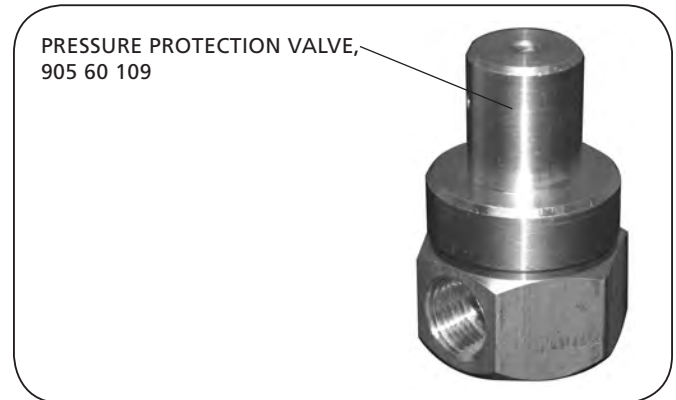

**Figure 17B**

**Optional Pressure Protection Valve**

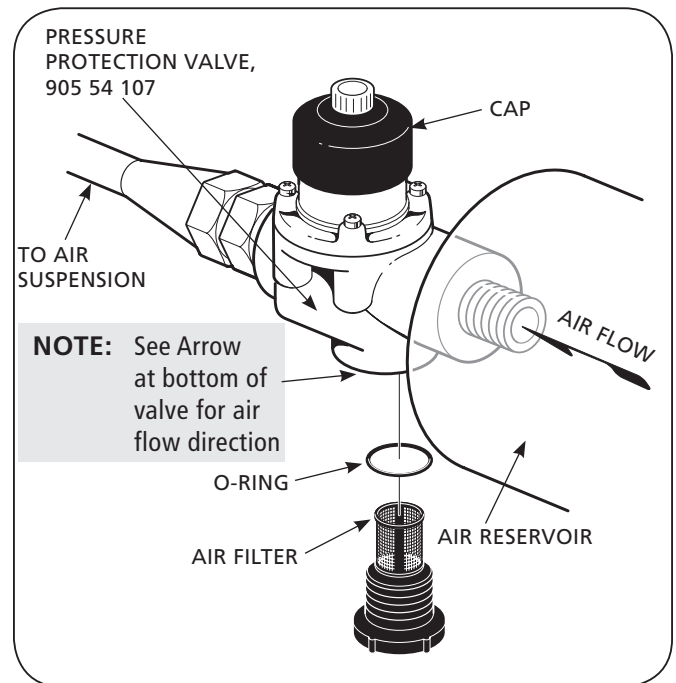

**IMPORTANT:** Axle alignment can only be achieved if the frame bracket pivot holes are the same distance from the kingpin, left and right. Axle alignment should always be done while the trailer is empty.

1. To properly align the suspension, the trailer should be pulled in a straight line for a sufficient distance to insure there are no binds in the suspension.
2. Alignment can be achieved with an optical device designed especially for this purpose or manually by the following manner: Measure the distance from the kingpin to the center line of the spindles on the front axles. It is recommended that spindle extensions be utilized. Dimensions A and B must be equal within 1/8" (3mm). Dimension E is equal to the distance between the trailer center line and the axle center line (**Figure 18**).

## EZ-Align (Non-welded) Connection Axle Alignment

1. Loosen the 1 1/8" pivot bolt connection nut (**Figure 19**).

**IMPORTANT:** DO NOT remove weld from bolt head.

2. Rotate bolt head clockwise to move axle forward (A arrows); counterclockwise to move axle rearward (B arrows) (**Figure 19**).
3. Retorque the pivot bolt connection nut, no weld required (refer to **Figure 7**, page 8). Refer to **Table 2 Pivot Bolt Torque Chart** on page 8.

**IMPORTANT:** DO NOT weld EZ-Align pivot bolt (alignment block) assembly to alignment collars on frame brackets (**Figure 20**).

**IMPORTANT:** The EZ-Align design maintains proper alignment under correct torque without welding.

**Figure 18** Slider Suspension Alignment

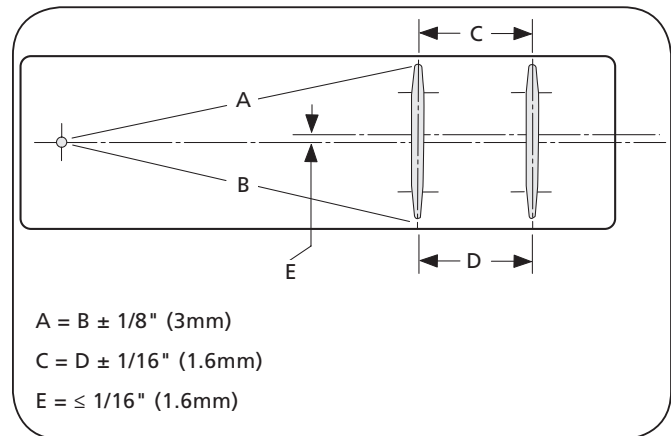

**Figure 19** Ez-Align

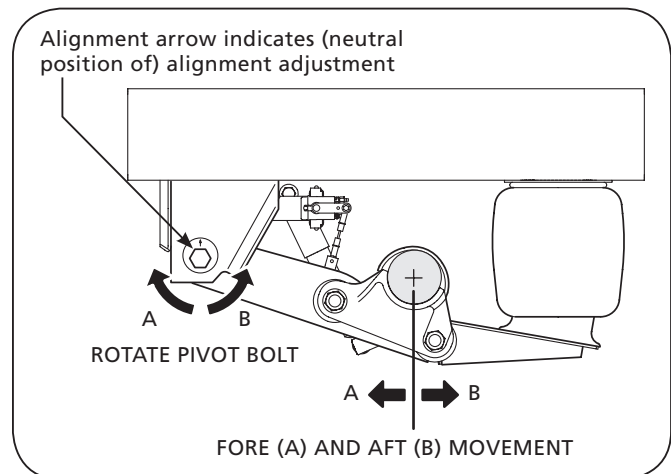

**Figure 20** Ez-Align Non-Welded Style Assembly

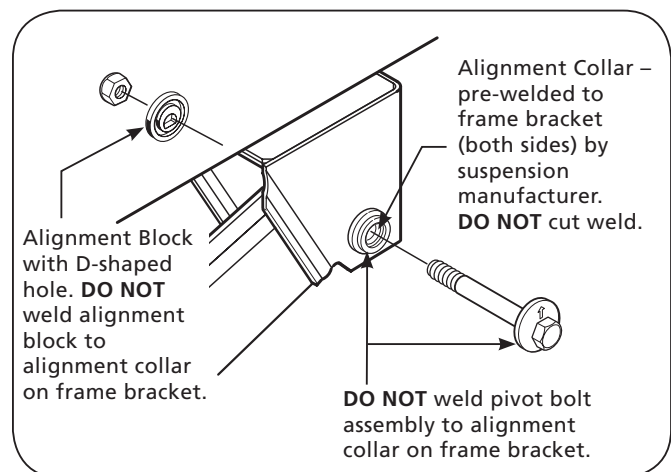

## Suspension Air Springs

**IMPORTANT:** Air springs must be replaced with the proper air spring for your application. Check the flexible member and piston for the part number. If the part number is not available, refer to **Figure 2** on page 3 to identify your specific model or refer to the OEM vehicle build specifications.

**NOTE:** For further assistance with air spring part number identification contact SAF-HOLLAND technical assistance at 888-396-6501.

**IMPORTANT:** It is recommended that the vehicle be unloaded before beginning service procedures.

1. Support vehicle frame with adequate jack stands. Set jack stand height at approximately 2" (51mm) above the suspension's specified ride height (**Figure 11**, page 10).

**WARNING** Failure to properly support suspension during maintenance may allow suspension to fall which, if not avoided, could result in death or serious injury.

**NOTE:** The height control valve may be used as an improvised jack by disconnecting the lower height control valve (HCV) linkage and moving the HCV control arm to "up" position to raise vehicle (**Figure 13**, page 11). With vehicle raised above the height specified in step 1, position jack stands under vehicle frame at OEM specified locations and move control arm to "down" position to lower vehicle onto jack stands. Hold control arm down until air springs are completely exhausted.

2. Exhaust air from suspension system by:
  - Automatic control – use height control valve by disconnecting link at lower connection, then rotate control arm to exhaust (approx. 45° down) position, or
  - Disconnect air supply line from air spring.

**IMPORTANT:** If air spring has a leak and is deflated, step 2 must still be performed.

3. Disconnect and remove old air spring assembly (**Figure 21**).
4. Install new air spring assembly and torque fasteners (refer to **Torque Charts**, page 8).
5. Reconnect air supply line and link connections.
6. Recharge air system in excess of 75 psig (5.2 bars), and check system for leaks.

**IMPORTANT:** It is the responsibility of the air system installer to secure all air lines and check for any air leaks. If air leaks are detected, repair as required. Failure to eliminate the air leaks may compromise the suspension performance.

**Figure 21** Suspension Air Spring

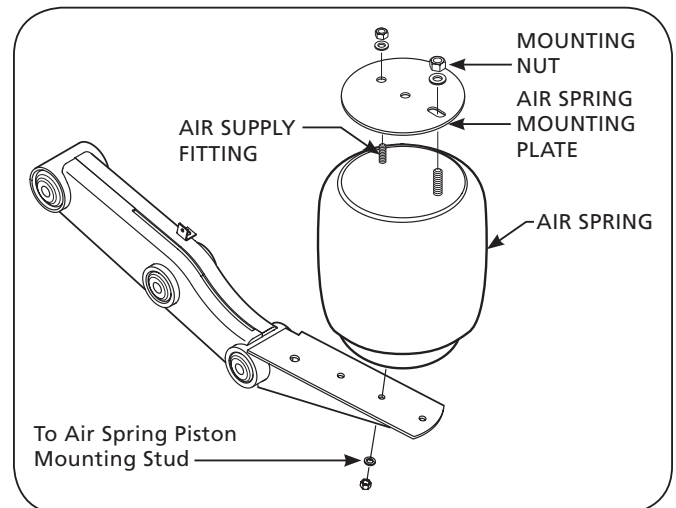

**NOTE:** Refer to RLU Series Parts List, XL-AR425, for correct part replacements.

## Shock Absorbers

**IMPORTANT:** Shock absorber must be replaced with the proper shock absorber. Check shock for part number. If part number is not available, refer to **Figure 2** on page 3 to identify your specific model (the last two digits of the model number relate to ride height), or refer to the OEM vehicle build specifications.

1. It is recommended the vehicle be unloaded. Block vehicle to prevent rolling.

**⚠ WARNING** Failure to chock tires prior to beginning maintenance could allow vehicle rollaway which, if not avoided, could result in death or serious injury.

2. Vehicle must be at model's specified ride height or below to assure that tension is relieved on shocks.
3. Remove upper and lower mounting bolts and shock absorber (**Figure 22**).
4. Replace with correct shock absorber and fasteners.
5. Torque nuts to 150 ft. lbs. (203 Nm) lubricated.
6. If ride height was changed, you must return the ride height to your model's ride height requirement.

**Figure 22**

**Shock Absorber**

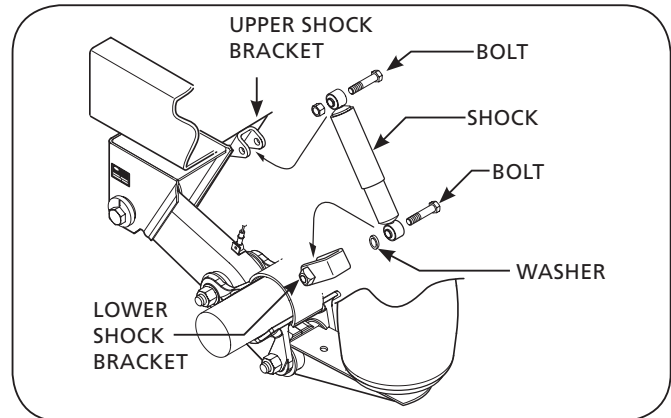



## Pivot and Axle Connection Rubber Bushings

**IMPORTANT:** When replacing the rubber bushings at these connections be sure the proper SAF-HOLLAND SRK (Service Repair Kit) is used as they contain all necessary parts to service one axle (2 kits per tandem). Refer to Service Repair Kit section of RLU Series Parts List (XL-AR425) for proper SRK. It may be advantageous to service both pivot and axle connections at the same time.

**NOTE:** The SAF-HOLLAND Bushing Service Tool, Part No. 505 44 012 is available to ease removal and replacement of bushings. Contact your SAF-HOLLAND distributor or Parts List for details (*Figure 23*).

**IMPORTANT:** It is recommended that the vehicle be unloaded before beginning service procedures.

1. Support vehicle frame with adequate jack stands. Set jack stand height at approximately 2" (51mm) above the suspension's specified ride height (*Figure 11*, page 10).

**⚠ WARNING** Failure to properly support suspension during maintenance may allow suspension to fall which, if not avoided, could result in death or serious injury.

**NOTE:** The height control valve may be used as an improvised jack by disconnecting the lower height control valve (HCV) linkage and moving the HCV control arm to "up" position to raise vehicle (*Figure 13*, page 11). With vehicle raised above the height specified in step 1, position jack stands under vehicle frame at OEM specified locations and move control arm to "down" position to lower vehicle onto jack stands. Hold control arm down until air springs are completely exhausted.

*Figure 23*

*Bushing Service Tool*

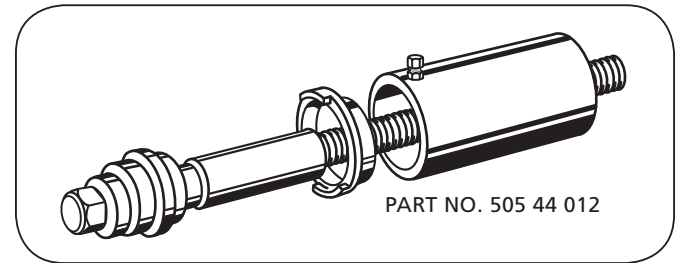

*continued*

## Pivot and Axle Connection Rubber Bushings *continued*

**CAUTION** Exhaust all air pressure from the system or personal injury may occur.

2. Exhaust air from the suspension system by:
  - Automatic control — use height control valve by disconnecting link at lower connection, then rotate control arm to exhaust (approx. 45° down) position, or
  - Disconnect air supply line from air spring.
3. If servicing all equalizing beam bushings, equalizing beam must be completely removed.

**NOTE:** If servicing the front pivot bushing only and using the SAF-HOLLAND Bushing Service Tool, remove the pivot bolts and rotate front of equalizing beams downward to gain access to bushing.

4. Disconnect air spring and shock absorber at lower connections.
5. Disconnect height control valve linkage at lower connection (**Figure 14**, page 12).
6. Disconnect front pivot and axle connection hardware then remove equalizing beam (**Figure 24**).
7. Inspect axle adapters for wear, cracks and failed welds. Axle adapters should have a 1/2" (13mm) (3 pass) fillet weld (refer to proper SAF-HOLLAND NS-65-84 or NS-65-108 specifications for RLU Series). Replace all worn or cracked axle adapters.
8. Inspect equalizing beams for wear, cracks and failed welds. Replace cracked equalizing beams.

**IMPORTANT:** NEVER repair a cracked equalizing beam. DO NOT weld cracks. Secondary weld failures during use could cause loss of vehicle control.

**WARNING** Failure to replace a cracked equalizing beam could cause loss of vehicle control which, if not avoided, could result in death or serious injury.

**Figure 24** Pivot And Axle Connections

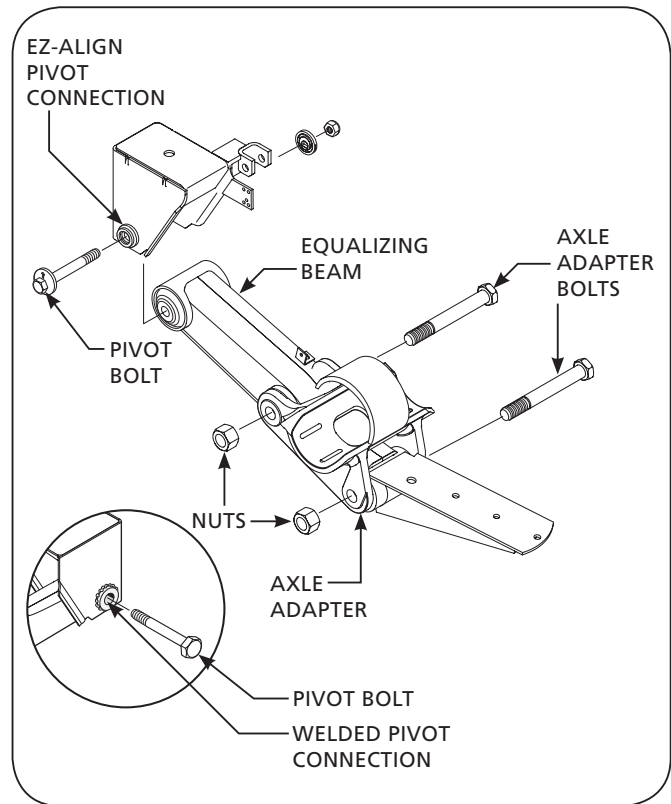

- Press out old bushing(s) using a Bushing Service Tool, Part No. 505 44 012.

**IMPORTANT:** DO NOT use an open flame or other heat source to remove the bushings.

- Clean out all foreign material from bushing receptacle(s). Lubricate new bushing(s) with approved lubricant, or a soap and water solution.

**IMPORTANT:** DO NOT use oil-based lubricant or brake fluid, as it can cause damage to the rubber.

- Press new bushing(s) in beam. Bushing(s) must be centered in beam receptacles. It may be necessary to push bushing past center approximately 1" (25.4mm) and then re-center the bushing to relieve the rubber (**Figures 25 and 26**).
- Re-install equalizing beam with new wear washers, bolts and nuts. Be sure to install wear washers in proper locations (**Figure 27**). Position at ride height and properly torque fasteners (refer to **Torque Charts**, page 8).
- Reconnect air springs, shock absorbers and height control valve linkage. Properly torque fasteners (refer to **Torque Charts**, page 8).
- Remove jack stands. Build system air pressure in excess of 75.psig (5.2 bars) and check for leaks in air system at all connections.

**IMPORTANT:** It is the responsibility of the air system installer to secure all air lines and check for any air leaks. If air leaks are detected, repair as required. Failure to eliminate the air leaks could compromise the suspension performance.

**Figure 25** Equalizing Beam Bushings Location

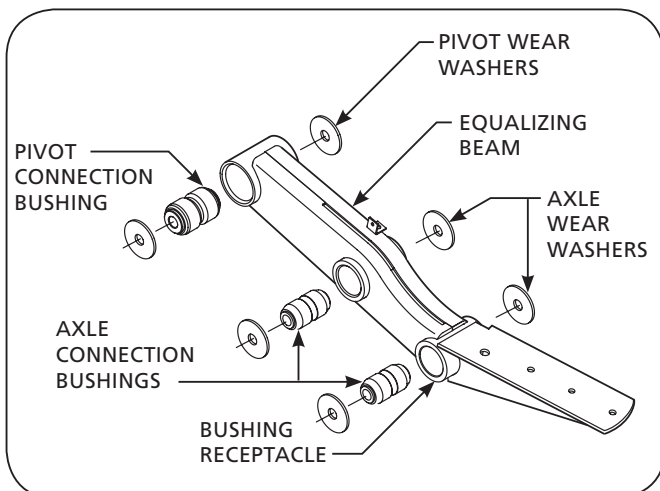

**Figure 26** Centering Bushings In Equalizing Beam

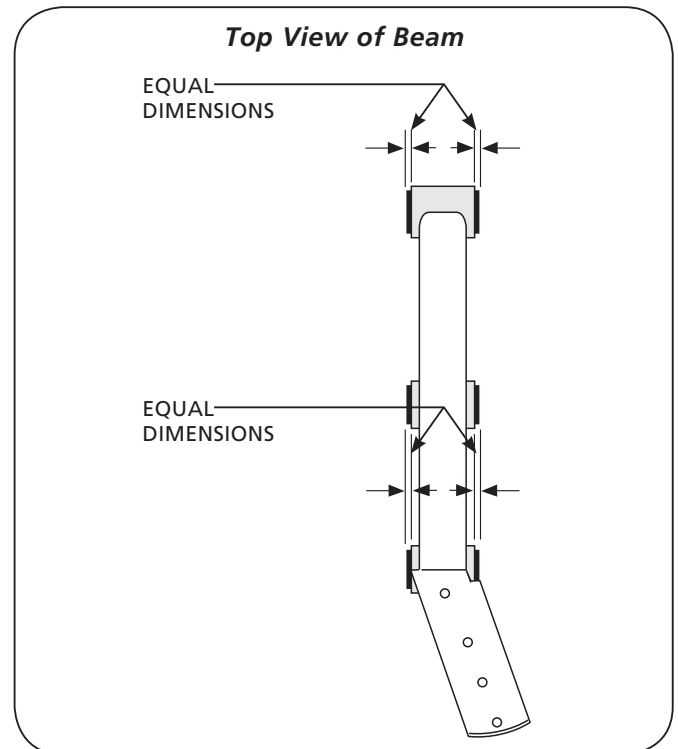

**Figure 27** Wear Washer Locations

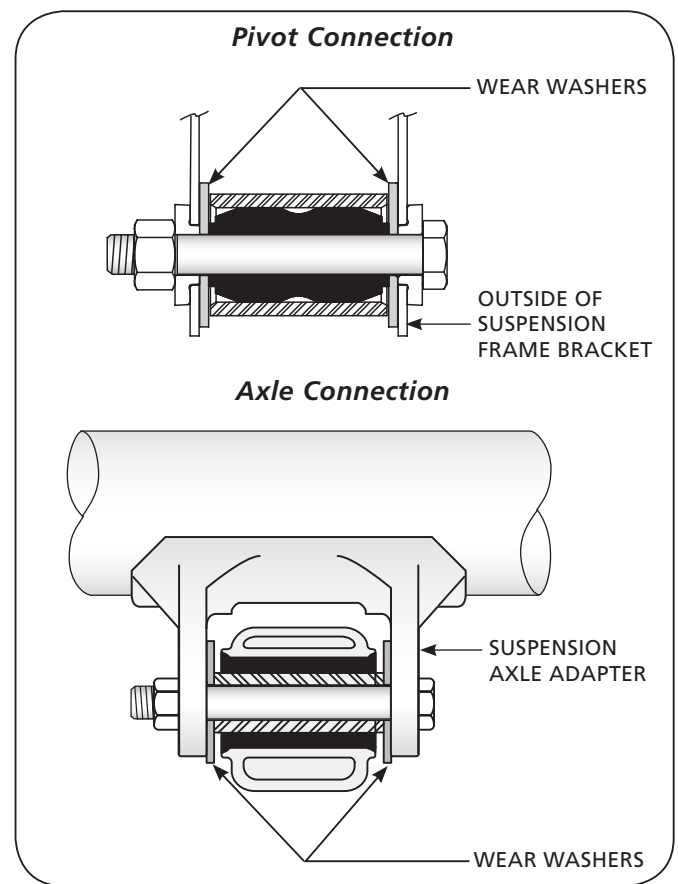

## Equalizing Beam

**IMPORTANT:** It is recommended that the vehicle be unloaded before beginning service procedures.

1. Support vehicle frame with adequate jack stands. Set jack stand height at approximately 2" (51mm) above the suspension's specified ride height (**Figure 11**, page 10).

**WARNING** Failure to properly support suspension during maintenance could allow suspension to fall which, if not avoided, could result in death or serious injury.

**NOTE:** The height control valve may be used as an improvised jack by disconnecting the lower height control valve (HCV) linkage and moving the HCV control arm to "up" position to raise vehicle (**Figure 13**, page 11). With vehicle raised above the height specified in step 1, position jack stands under vehicle frame at OEM specified locations and move control arm to "down" position to lower vehicle onto jack stands. Hold control arm down until air springs are completely exhausted.

2. Exhaust air from the suspension system by:
  - Automatic control — use height control valve by disconnecting link at lower connection, then rotate control arm to exhaust (approx. 45° down) position, or
  - Disconnect air supply line from air spring.
3. Disconnect air springs, shock absorbers and height control valve linkage at the lower connections.
4. Disconnect front pivot and axle connection hardware then remove equalizing beam(s) (**Figure 28**).
5. Install new equalizing beam(s) with new wear washers, bolts and nuts. Be sure to install wear washers in proper location (**Figure 27**, page 19). Position at ride height and properly torque fasteners (refer to **Torque Charts**, page 8).
6. Reconnect air springs, shock absorbers and height control valve linkage. Properly torque fasteners (refer to **Torque Charts**, page 8). Check air system connections, including air springs for leaks.

**IMPORTANT:** It is the responsibility of the air system installer to secure all air lines and check for any air leaks. If air leaks are detected, repair as required. Failure to eliminate the air leaks may compromise the suspension performance.

7. Remove jack stands. Build system air pressure in excess of 75 psig (5.2 bars).

**Figure 28** Pivot And Axle Connections

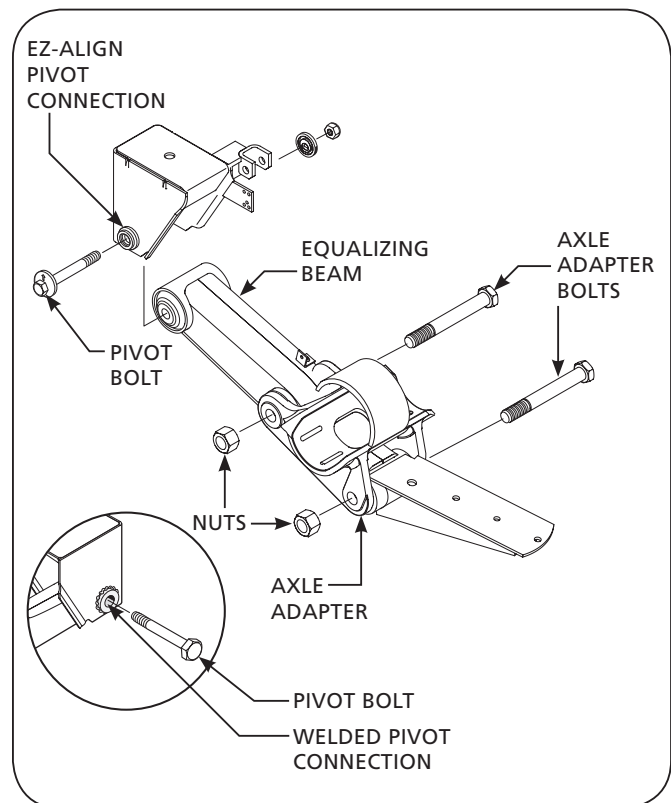

## Frame Bracket

When replacing frame bracket(s), see RLU Series Parts List Manual, XL-AR425, for correct Service Repair Kit.

1. Place jack stands at necessary height.

**⚠ WARNING** Failure to properly support suspension during maintenance could allow suspension to fall which, if not avoided, could result in death or serious injury.

2. Remove tires.
3. On the side of the trailer frame, mark the mounting location of the frame bracket to be replaced.
4. Remove old frame bracket.

**IMPORTANT:** Carefully air arc the welds connecting the frame bracket to the frame. **DO NOT** use frame if frame material is damaged. Repair the frame and then install the frame brackets.

**⚠ WARNING** Failure to repair damaged frame could cause damage to suspension with possible loss of vehicle control which, if not avoided, could result in death or serious injury.

5. Install a new frame bracket per location marks, and weld per SAF-HOLLAND NS-65-07-CI specification.
6. Realign trailer per instructions on page 14.
7. Reinstall tires and other suspension components, then remove jack stands.

## Troubleshooting

PROBLEM	POSSIBLE CAUSE AND REMEDY
All air springs flat (no air).	<b>Insufficient air pressure to suspension.</b> Build air pressure in excess of 75 psig (5.2 bars). Malfunctioning air pressure protection valve – test the valve using instructions on page 13. Replace if necessary. Check air compressor. HCV control valve not working – follow HCV inspection procedure (refer to page 11).
	<b>Air leakage from the suspension air system or the air brake system.</b> Test for air leakage due to loose fittings or damaged air lines, air springs, brake actuators or control valve. Tighten loose fittings to stop leakage and/or replace worn or damaged parts.
Air springs deflate rapidly when vehicle is parked.	<b>Air leakage from the suspension air system.</b> Test for air leakage due to loose fittings between air tank and air suspension or damaged air lines, air springs or height control valve. Apply a soapy solution to connections and air springs if necessary to check for bubbles (leaks). Tighten loose fittings to stop leakage and/or replace worn or damaged parts with new ones.
Ride height too high or too low.	<b>Height control valve out of adjustment.</b> Re-adjust the height control valve.
Air springs ruptured.	<b>Tire, tire rim or brake component rubbing air spring.</b> Check inside to inside tire dimension. There must be 1" (25.4mm) minimum clearance around air spring. If not, it may be necessary to reinstall suspension. Use tire rim back spacers to provide more clearance.
	<b>Spring brake chamber rubbing air spring.</b> Relocate chamber or rotate clamp ring for more clearance.
Air spring failed.	<b>Continual or repeated over-extension of the air spring.</b> Visually inspect for broken or loose shock absorber or shock absorber mounting bracket. Reconnect loose parts and replace any defective parts. Check the adjustment of the height control valves (refer to page 10).
	<b>Air spring(s) worn out.</b> Replace.
	<b>Air leak or damaged line.</b> Locate and repair. Air spring punctured or leaking – replace with proper air spring. Then check for proper clearance around air spring, 1" (25.4mm) minimum. Also check shock absorbers.
	<b>"Temporary Operation."</b> If air loss occurs in the air suspension system and after attempts to repair have failed to correct the problem, it is recommended that the Height Control Valve Linkage be disconnected and all air exhausted from the system. There is an internal rubber bumper built into the air spring which makes it possible to operate the vehicle cautiously while driving at a reduced speed to the nearest place of repair.
Front pivot connection worn and loose.	<b>Welded pivot alignment plate(s) not welded.</b> Weld per installation instructions (refer to SAF-HOLLAND NS-65-78 and also Figure 8 on page 8).
	<b>Worn pivot alignment plate(s).</b> If alignment plates are worn, replace and realign axles (refer to page 14).
	<b>EZ-Align pivot alignment block(s) worn.</b> If alignment blocks are worn, replace and realign axles (refer to page 14).
	<b>Front pivot bolt loose.</b> Connection not properly tightened, refer to page 7, step 10 for tightening procedure. Replace all worn or damaged components.
	<b>Excessive lateral axle walk.</b> 3/4" (19mm) is maximum. Axle connection bolts loose – properly tighten, refer to step 6 on page 7. Axle adapter welds failed – replace adapters or remove old welds and reweld. Refer to proper SAF-HOLLAND specifications for applicable model. Front pivot and/or axle connection bushings worn – replace with proper SRK (refer to RLU Series Parts List Manual, XL-AR425).
Shock absorber failures.	<b>Over-extending shock absorbers.</b> Suspension set at improper ride height – re-adjust height control valve. Suspension mounted at wrong ride height – check specification sheet, or refer to page 10 for correct ride height and adjustment procedure. Wrong length or improper replacement shock absorber(s) – replace if necessary (refer to page 16).
Excessive tire wear.	<b>Alignment plates are not welded, are worn, or the axle is out of alignment.</b> Inspect for damage and replace components as necessary or realign and weld to specifications on welded style alignments. Realign and tighten to specifications on EZ-Align (non-weld) style alignments (refer to page 8).
	<b>Loose or worn bushings at pivot or axle connection.</b> Inspect for damage and replace components as necessary (refer to pages 17 and 18), or if loose, tighten connection(s) to proper specification (refer to page 8). Then, check axle alignment and realign if necessary (refer to page 14). If worn, replace with proper Service Repair Kit (refer to RLU Series Parts List Manual, XL-AR425).
	<b>Worn bushing tube ends and/or face of wear washers at axle connections.</b> Contact SAF-HOLLAND Service Department.
	<b>Suspension not properly installed.</b> Contact SAF-HOLLAND Service Department and/or check Trailer manufacturer for proper suspension installation; correct where necessary.





From fifth wheel rebuild kits to suspension bushing repair kits, SAF-HOLLAND Original Parts are the same quality components used in the original component assembly.

SAF-HOLLAND Original Parts are tested and designed to provide maximum performance and durability. Will-fits, look-alikes or, worse yet, counterfeit parts will only limit the performance potential and could possibly void SAF-HOLLAND's warranty. Always be sure to spec

SAF-HOLLAND Original Parts when servicing your SAF-HOLLAND product.

**SAF-HOLLAND USA • 888.396.6501 • Fax 800.356.3929**  
[www.safholland.us](http://www.safholland.us)

**SAF-HOLLAND CANADA • 519.537.3494 • Fax 800.565.7753**  
**WESTERN CANADA • 604.574.7491 • Fax 604.574.0244**  
[www.safholland.ca](http://www.safholland.ca)

**SAF-HOLLAND MEXICO • 52.55.5362.8743 • Fax 52.55.5362.8743**  
[www.safholland.com.mx](http://www.safholland.com.mx)

[info@safholland.com](mailto:info@safholland.com)