

HOLLAND RL SERIES

TOP MOUNT,
FIXED FRAME,
ON/OFF HIGHWAY
TRAILER AIR
SUSPENSIONS

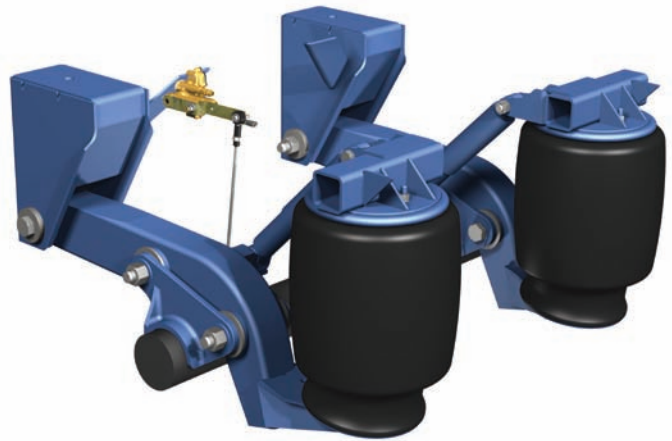



RL SERIES AIR-RIDE SUSPENSION

23,000, 25,000 & 30,000 lbs.
(10,430, 11,340 & 13,608 kg) **CAPACITY**

RIGID TRAILING ARMS

extends brake and tire life through better load equalization.

OPTIONAL AIR CONTROLS

Kits featuring leveling, pressure protection, and exhaust valves are available for a wide range of vehicle applications.

OPTIONS

- EZ-Align® on both sides
Not available on RL-300
- Air Control Kits
- Center Bag Lift (CBL)
- Steel Cable Down-Straps
Available on RL-300

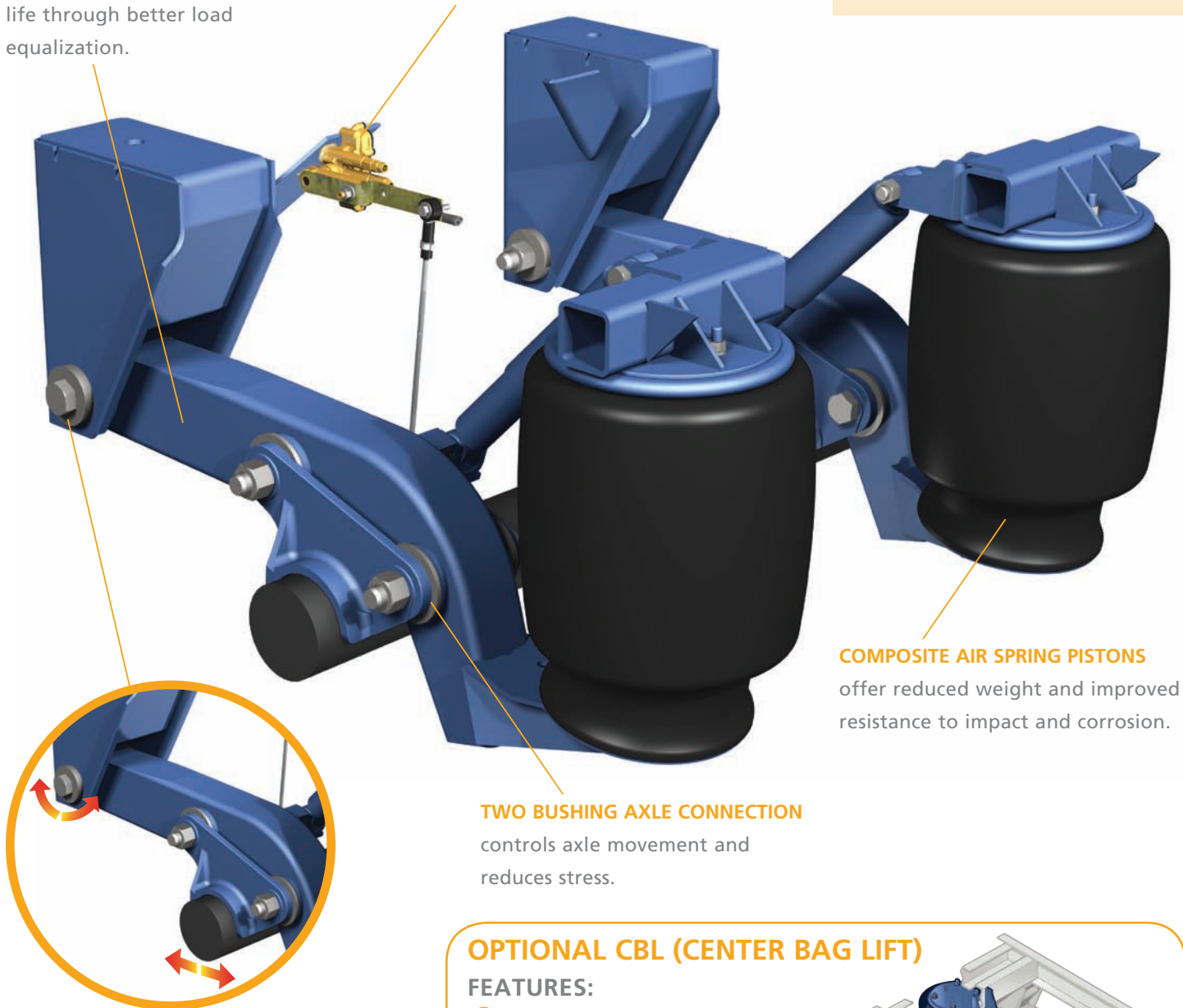

COMPOSITE AIR SPRING PISTONS

offer reduced weight and improved resistance to impact and corrosion.

TWO BUSHING AXLE CONNECTION

controls axle movement and reduces stress.

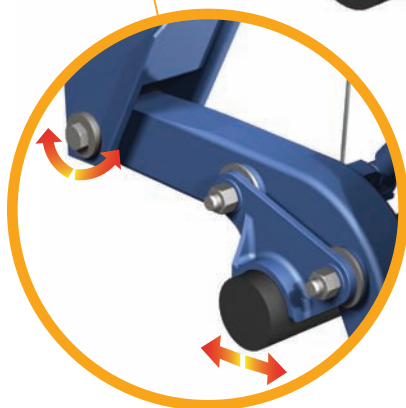

EZ-ALIGN™

Alignment system requires no special replacement parts or disassembly.

Not available on RL-300

OPTIONAL CBL (CENTER BAG LIFT)

FEATURES:

- Easy installation
- Can be retrofitted to RL Series Air Suspensions*
- Mounts below frame for tight clearance applications

** Not available on all models*

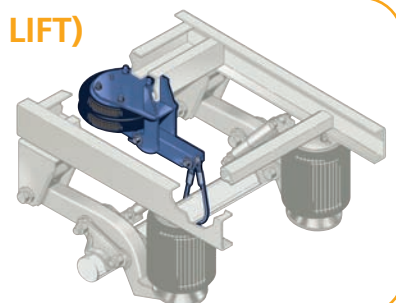

MODEL SPECIFICATIONS

RL-230

CAPACITY		TANDEM AXLE SPACING		WHEEL SIZE		
		MIN.	MAX.			
23,000 LBS. (10,430 KG)		45.5	122.0	20/22		
MODEL	RIDE HEIGHT	AXLE TRAVEL		SUSP. WEIGHT (Complete)	"A"	LIFT AXLE
		TOTAL	UP			
RL-230-12-3	12.0	7.0	3.0	280	5.25	NO
RL-230-14-3	14.0	8.0	3.0	286	7.25	
RL-230-15-3	15.0	8.0	3.0	291	8.25	
RL-230-16-3	16.0	8.0	3.0	304	10.59	
RL-230-17-3	17.0	8.0	3.0	308	10.59	
RL-230-15-4	15.0	8.0	3.75	291	8.25	YES
RL-230-16-4	16.0	8.0	3.89	304	10.59	
RL-230-17-4	17.0	8.0	4.12	308	10.59	

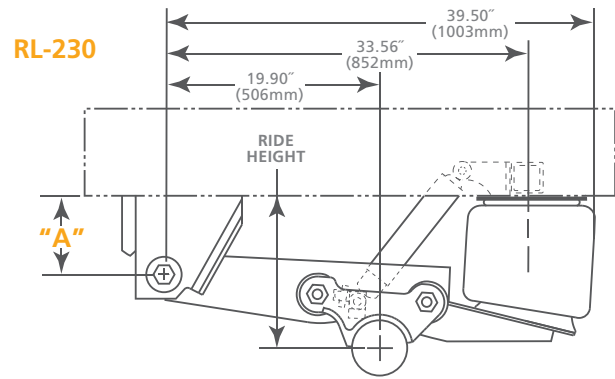

RL-250

CAPACITY		TANDEM AXLE SPACING		WHEEL SIZE		
		MIN.	MAX.			
25,000 LBS. (11,340 KG)		49.0	122.0	20/22		
MODEL	RIDE HEIGHT	AXLE TRAVEL		SUSP. WEIGHT (Complete)	"A"	LIFT AXLE
		TOTAL	UP			
RL-250-12	12.0	8.0	3.0	340	5.25	NO
RL-250-14	14.0	9.5	4.5	352	8.25	YES
RL-250-15	15.0	9.5	5.5	352	8.25	YES
RL-250-16	16.0	9.6	4.6	370	10.59	YES
RL-250-17	17.0	9.6	5.6	370	10.59	YES

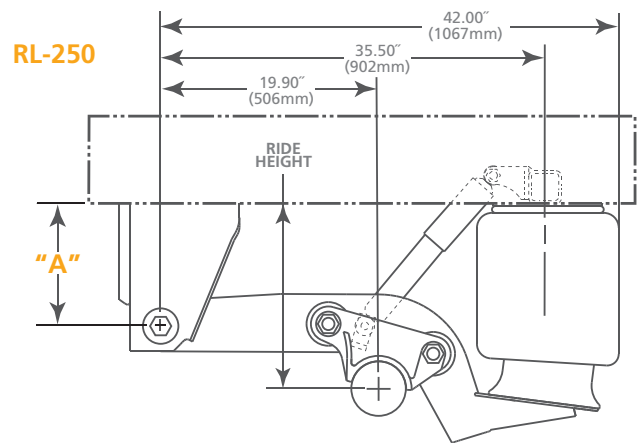

RL-300

CAPACITY		TANDEM AXLE SPACING		WHEEL SIZE			
		MIN.	MAX.				
30,000 LBS. (13,608 KG)		49.0	122.0	20/22			
MODEL	RIDE HEIGHT	AXLE TRAVEL		SUSP. WEIGHT (Complete)	"A"	"B"	LIFT AXLE
		TOTAL	UP				
RL-300-12	12.0	Please contact Trailer Application Engineering for Application Specs.		400	7.25	19.70	YES
RL-300-14	14.0	8.7	3.7	400	8.25	19.60	YES
RL-300-15	15.0	8.5	4.2	400	10.60	20.00	YES
RL-300-16	16.0	9.0	4.2	420	10.59	19.75	YES
RL-300-17	17.0	9.0	5.2	420	10.60	19.75	YES

BELOW FRAME APPLICATION SPECIFICATIONS (Requires between frame clearance)

RL-300-14	14.0	Please contact Trailer Application Engineering for Application Specs.		420	10.60	20.00	NO
RL-300-15	15.0	Please contact Trailer Application Engineering for Application Specs.		420	10.60	19.75	YES

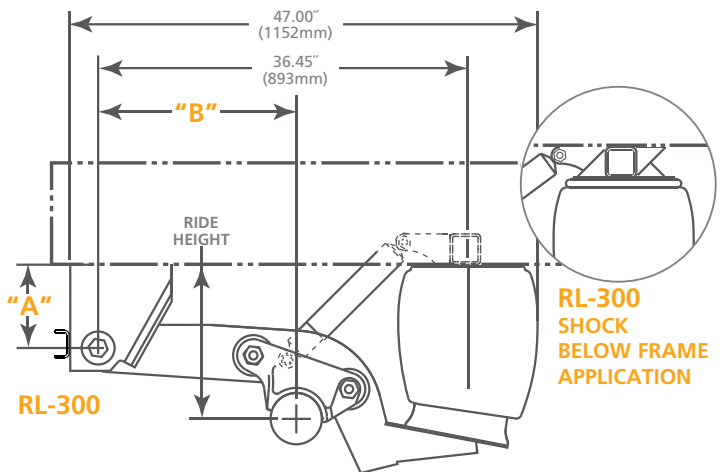

RL SERIES TRAILER APPLICATIONS

- Platform
- Logging
- Bottom Dump
- Livestock
- Specialty Trailer
- Reefer
- Grain
- Dump
- Tanker
- Wide Spread Van





SAF's legacy started in 1881 when Paul Zill, a blacksmith from Keilberg, Germany developed the Zill two-way plow for the agricultural industry. Mr. Zill's blacksmith shop expanded into a small family operation as popularity for his plow grew and agricultural axles were added to the product line. Time passed - and the family operation evolved to become Otto Sauer Achsen Fabrik (SAF), a leader in the design and manufacture of integrated axle and suspension systems for commercial trailers.

Similar to SAF, Holland's legacy also started in the agricultural industry in 1910 with the introduction of a safety release hitch for horse drawn plows. Founding father, Gerrit Den Besten, began the "Safety Release Clevis Company" in Corsica, South Dakota. The company found new market opportunities in the automotive industry and moved operations to Holland, Michigan. Renamed The Holland Hitch Company, the family owned business grew into a global supplier in the commercial transportation industry.

Today - these two historical companies are together as SAF-HOLLAND, a global leader in the design, manufacture, and distribution of quality engineered components, systems, and services to the commercial vehicle industry.

SAF-HOLLAND specializes in coupling, lifting, and suspension systems for trucks, buses, tractors, and trailers. SAF-HOLLAND products are sold and serviced under the SAF and Holland brand names from over 4,600 distributor and OEM locations around the world.



From fifth wheel rebuild kits to suspension bushing repair kits, SAF-HOLLAND Original Parts are the same quality components used in the original component assembly. SAF-HOLLAND Original Parts are tested and designed to provide maximum performance and durability. Will-fits, look-alikes or worse yet counterfeit parts will only limit the performance potential and could possibly void SAF-HOLLAND's warranty. Always be sure to spec SAF-HOLLAND Original Parts when servicing your SAF-HOLLAND product.

SAF-HOLLAND USA, Inc.
888.396.6501 Fax 800.356.3929

SAF-HOLLAND Canada Limited
519.537.3494 Fax 800.565.7753
Western Canada 604.574.7491 Fax 604.574.024

www.safholland.com

