

## Installation and Operation Manual

### CBu/CBXu and CBy/CBXY Series Fixed Frame Underslung and Yoke Mount Trailer Air Suspension

- For Disc and Drum Brake Applications

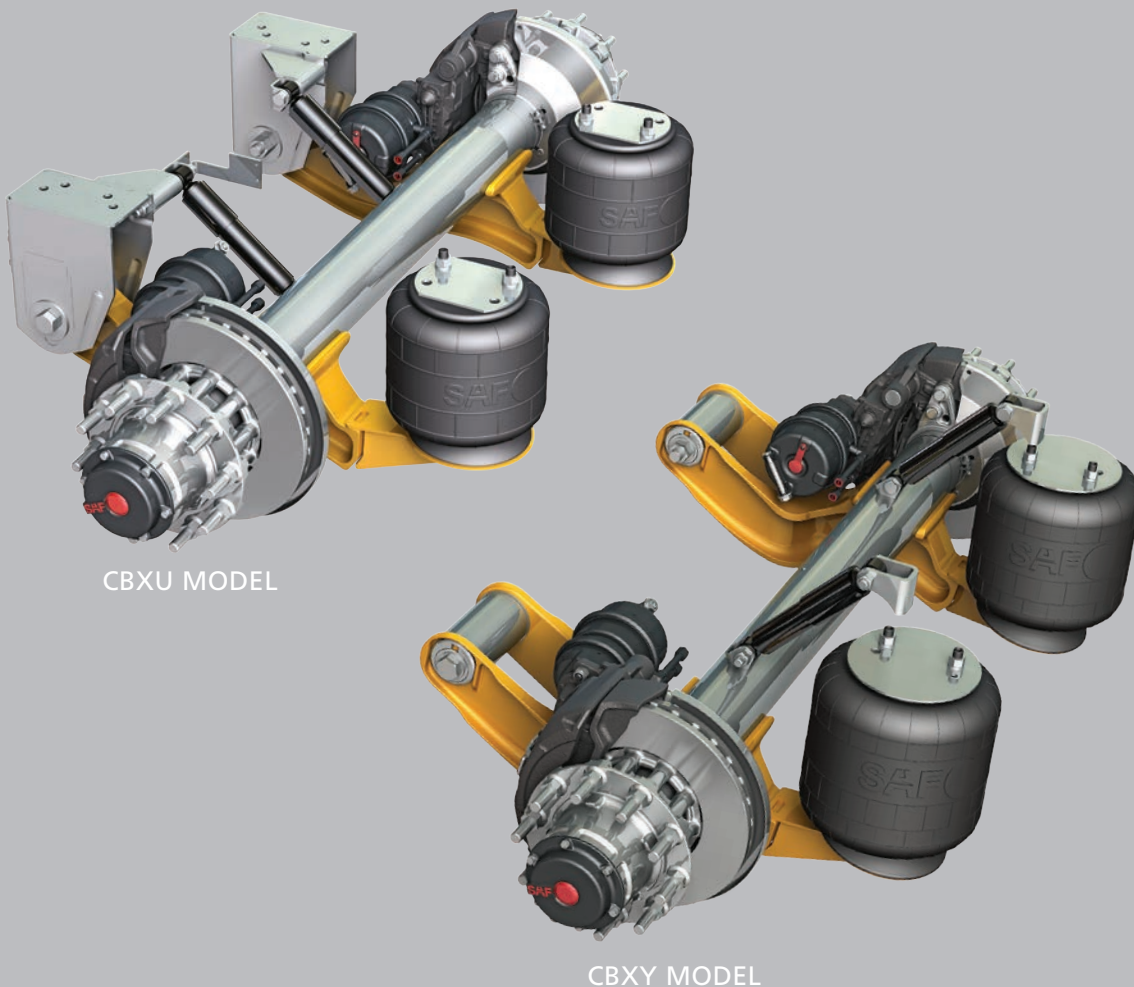



Contents	Page
Introduction.....	3
Warranty.....	3
Notes, Cautions, and Warnings .....	3
Section 1 – General Safety Instructions .....	4
Section 2 – Standard Decal Requirements .....	5
Section 3 – CBU/CBXu Model Identification .....	6
Section 4 – CBU/CBXu Nomenclature.....	6
Section 5 – CBy/CBXy Model Identification.....	7
Section 6 – CBy/CBXy Nomenclature .....	7
Section 7 – Welding Standards .....	8

Contents	Page
Section 8 – Standard Air Control System Installation .....	9
Section 9 – Suspension Assembly Installation .....	10
Section 10 – Ride Height Adjustment .....	11
Section 11 – SwingAlign™ Axle Alignment.....	13
Section 12 – CBy/CBXy Axle Alignment and Adjustments....	14
Section 13 – Brake Adjustment Instructions.....	15
Section 14 – Pre-Operation Information .....	16
Section 15 – Torque Specifications .....	17
Section 16 – Maintenance and Service Schedule.....	18

## Introduction

This manual provides the necessary information for the installation and operation of the SAF-HOLLAND® Fixed Frame Under Mount and Yoke Mount. The suspensions depicted throughout this manual are of the CBU/CBXu Series suspensions and also the CBy/CBXy Series suspensions.

The CBXu and CBXy suspension includes a premium 5.75" diameter axle. The CBU and CBy suspension includes a standard 5.00" diameter axle. For axle end and/or brake servicing information or component replacements, refer to Drum Brake Manual XL-TA10006OM-en-US, Disc Brake Manual XL-SA10059OM-en-US or contact Customer Service at 888-396-6501.

This suspension uses air drawn from the tractor air system to pressurize the air springs. The height control valve (HCV) regulates the air pressure required for varying loads while maintaining the design ride height. This suspension can provide a cushioned ride throughout the load range, from empty to fully loaded.

The suspension also provides excellent side-to-side and axle-to-axle loading which helps equalize and control braking.

Read this manual before using or servicing this product and keep it in a safe location for future reference. Updates to this manual, which are published as necessary, are available on the internet at [www.safholland.us](http://www.safholland.us).

When replacement parts are required, SAF-HOLLAND® highly recommends the use of only SAF-HOLLAND® Original Parts. A list of technical support locations that supply SAF-HOLLAND® Original Parts and an Aftermarket Parts Catalog are available on the internet at [www.safholland.us](http://www.safholland.us) or contact Customer Service at 888-396-6501.

## Warranty

Refer to the complete warranty for the country in which the product will be used. A copy of the written warranty is included with the product or available on the internet at [www.safholland.com](http://www.safholland.com).

## Notes, Cautions, and Warnings

Before starting any work on the unit, read and understand all the safety procedures presented in this manual. This manual contains the terms "NOTE", "IMPORTANT", "CAUTION", and "WARNING" followed by important product information. These terms are defined as follows:

**NOTE:** Includes additional information to enable accurate and easy performance of procedures.

**IMPORTANT:** Includes additional information that if not followed could lead to hindered product performance.

### CAUTION

Used without the safety alert symbol, indicates a potentially hazardous situation which, if not avoided, could result in property damage.

### ⚠ CAUTION

Indicates a potentially hazardous situation which, if not avoided, could result in minor or moderate injury.

### ⚠ WARNING

Indicates a potentially hazardous situation which, if not avoided, could result in death or serious injury.

# 1. Safety Instructions

## General and Servicing Safety Instructions

- Read and observe all Warning and Caution hazard alert messages. The alerts provide information that can help prevent serious personal injury, damage to components, or both.

**⚠ WARNING** Failure to follow the instructions and safety precautions in this manual could result in improper servicing or operation leading to component failure which, if not avoided, could result in death or serious injury.

- All maintenance should be performed by a properly trained technician using proper/special tools, and safe procedures.

**NOTE:** In the United States, workshop safety requirements are defined by federal and/or state Occupational Safety and Health Act (OSHA). Equivalent laws could exist in other countries. This manual is written based on the assumption that OSHA or other applicable employee safety regulations are followed by the location where work is performed.

- Properly support and secure the vehicle from unexpected movement when servicing the unit.

**⚠ WARNING** Failure to properly support and secure the vehicle and axles prior to commencing work could create a crush hazard which, if not avoided, could result in death or serious injury.

- If possible, unload the trailer before performing any service procedures.
- After re-positioning the brake chamber, slack adjuster and/or ABS system as instructed in this manual, always consult the manufacturer’s manual for proper operation.
- Service both roadside and curbside of an axle. Worn parts should be replaced in sets. Key components on each axle’s braking system, such as friction material, rotors and drums will normally wear over time.
- Follow all manufacturer’s instructions on spring pressure and/or air pressure controls.

**⚠ WARNING** Failure to follow manufacturer’s instructions regarding spring pressure or air pressure control could allow unexpected release of energy which, if not avoided, could result in death or serious injury.

- DO NOT paint the wheel contact surfaces between the wheel and hub.

**IMPORTANT:** The wheel contact surfaces MUST be clean, smooth and free from grease.

**⚠ WARNING** Failure to keep wheel and hub contact surfaces clean and clear of foreign material could allow wheel/hub separations which, if not avoided, could result in death or serious injury.

- Only the wheel and tire sizes approved by the trailer builder can be used.

## Operational and Road Safety Instructions

- Before operating vehicle, ensure that the maximum permissible axle load is not exceeded and that the load is distributed equally and uniformly.
- Make sure that the brakes are not overheated from continuous operation.

**⚠ WARNING** Failure to minimize the use of brakes during overheating conditions could result in deterioration of brake efficiency which, if not avoided, could result in death or serious injury.

- The parking brake MUST NOT be immediately applied when the brakes are overheated.

**CAUTION** If the parking brake is immediately applied to the brakes when overheated, the brake drums or discs could be damaged by different stress fields during cooling.

- Observe the operating recommendation of the trailer manufacturer for off-road operation of the installed axles.

**IMPORTANT:** The definition of OFF-ROAD means driving on non-asphalt/non-concrete routes, e.g. gravel roads, agricultural and forestry tracks, on construction sites and in gravel pits.

**IMPORTANT:** Off-road operation of axles beyond the approved application design could result in damage and impair suspension system performance.

- Follow the recommended routine maintenance and inspections described in this manual. These procedures are designed so that optimum performance and operational safety are achieved.
- In the event of suspension air pressure loss, quickly reduce speed as safely as possible and remove the vehicle from traffic. If unable to remove vehicle from traffic, follow DOT safety requirements regarding emergency situations.
- Contact a qualified towing and/or service company to assist in repairing the vehicle or to move it to a qualified repair facility. DO NOT operate the vehicle in the absence of suspension air pressure; however in the event of an air system failure while in service, an internal rubber bumper built into the air spring will make it possible to temporarily operate the vehicle at reduced speed determined by road conditions.

**⚠ WARNING** Operating the vehicle without proper air pressure can cause tire failure, fire, or loss of vehicle control which, if not avoided, could result in death or serious injury.

## 2. Standard Decal Requirements

The following four (4) decals MUST be properly installed on the trailer prior to putting it in service:

- Tire Clearance Warning Decal: XL-AR356-01 (**Figure 1**).
- SwingAlign™ Axle Alignment Decal: XL-AR372-01 (**Figure 2**).
- Torque Decal: XL-AR436 (**Figure 3**).
- Axle Alignment Procedure Decal: XL-AS20032DC-en-US (**Figure 4**).
- Shear bolt decal: XL-AS20085DC-en-US (**Figure 5**).

**NOTE:** The CBy/CBXy Axle Alignment Decal (**Figure 4**) will only be provided when a CBy/CBXy series yoke mount suspension is installed.

It is the responsibility of the end user to periodically inspect all decals and ensure that they are clean and completely legible. If any decals are missing, loose, damaged or difficult to read, contact SAF-HOLLAND® Customer Service at 888-396-6501 to order replacements immediately.

Figure 1

**⚠ WARNING**

Minimum tire clearance **MUST** be maintained between tires and nearest point of contact on the suspension or vehicle. Premature tire wear, fire or loss of vehicle control could result from contact with the tires if clearances are not maintained.

**TIRE CLEARANCE REQUIREMENTS**

- **1 INCH (25.4 mm) MINIMUM VERTICAL** tire clearance is required between the top of the tire and the nearest point of contact above the tire when the air pressure is completely exhausted from the air suspension or when the axle is fully lifted if equipped with a suspension lift feature.
- **2 INCH (50.8 mm) MINIMUM LATERAL** tire clearance is required between the sides of the tire and the nearest point of contact through total travel of the air suspension. This includes when the wheels are fully turned in either direction if equipped with an SAF Self Steer Axle.

Copyright © 2011 • SAF-HOLLAND, Inc. www.safholland.us
XL-AR356-01

Figure 2

**SWINGALIGN™ NON-WELDED AXLE ALIGNMENT PROCEDURES**

**ALIGNMENT BOLT IS ON THE FRONT OF THE ROADSIDE FRAME BRACKET:**

**STEP 1.** Before aligning axle, pull trailer forward in a straight line for a sufficient distance to insure there are no binds in the suspension and then lock the brakes so the slider lock pins rest against the rear of the body rail holes.

**STEP 2.** Check to verify trailer is empty and emergency brakes are **NOT** engaged.

**STEP 3.** Rotate bolt **CLOCKWISE** to move axle forward (A arrows); **COUNTERCLOCKWISE** to move axle rearward (B arrows).

**ALIGNMENT BOLT HEAD**

**NOTE:** 1/2 turn of free play in either direction (A or B) is acceptable.

A = axle forward  
B = axle rearward

Copyright © 2011 • SAF-HOLLAND, Inc. www.safholland.us
XL-AR372-01

Figure 3

**CBX / CB FIXED FRAME TRAILER AIR SUSPENSION TORQUE SPECIFICATIONS**

Torques are with clean, lubricated threads. Always apply torque to nut, if possible.

Fastener Size	Pivot Connection	Shock	Air Spring		SwingAlign
	1-1/8"	3/4"	1/2"	3/4"	1/2"
<b>Torque ft.-lbs. (N•m)</b>	<b>550-600 (746-813)</b>	<b>140-175 (190-237)</b>	<b>30-40 (41-54)</b>	<b>40-45 (54-61)</b>	<b>50-60 (68-81)</b>

**REQUIRED RE-TORQUING SCHEDULE:**

- All fasteners after first three (3) months or 5,000 miles.
- At every routine preventative maintenance.
- At every brake relining.

Copyright © 2014 • SAF-HOLLAND®, Inc. www.safholland.us
XL-AR436

Figure 4

**CBY/CBXy SERIES AXLE ALIGNMENT PROCEDURE**

**STEP 1.** Before aligning the axle, pull the trailer forward in a straight line for sufficient distance to insure there are no binds in the suspension and then lock the brakes.

**STEP 2.** Check to verify trailer is empty and emergency brakes are **NOT** engaged.

**STEP 3.** Loosen the roadside pivot connection. Using two (2) 1/2" drive ratchet wrenches in the alignment collar square hole (One on either side of the pivot connection), rotate the wrenches frontward toward the front of the trailer to move the axle forward, or rotate the wrenches rearward toward the rear of the trailer to move the axle rearward. Once the desired alignment is reached, torque the pivot connection nut to SAF-HOLLAND® specifications.

**NOTE:** If the alignment cannot be reached within the allowable distance on the roadside pivot connection, the curbside pivot can be rotated frontward or rearward to achieve alignment. Always torque pivot nut after servicing connection.

**ROADSIDE ILLUSTRATED**

A = Axle Forward  
B = Axle Rearward

**NOTE:** The alignment collar's 1/2" drive hole should be above the bolt when installed correctly in all instances

Copyright © 2014 • SAF-HOLLAND, Inc. www.safholland.us
XL-AS20032DC-en-US

Figure 5

**SHEAR BOLT – FRONT PIVOT CONNECTION**

This suspension has been installed with a shear bolt front pivot connection design. This connection requires no torque check, but does **REQUIRE VISUAL INSPECTION**. Inspect that the spline has been sheared off and for any signs of movement:

- Prior to placing trailer in service.
- After three (3) months or 5,000 miles.
- At every routine preventative maintenance.
- At every brake relining.

**CAUTION:** compound or additional lubricant aware. This can lead to unpredictable clamp loads and unreliable axle alignment.

XL-AS20085DC-en-US Rev A

**SHEAR BOLT STYLES**

**E-20 HEAD SPLINE (AFTERMARKET)**

**SPLINE TO SHEAR OFF ONCE PROPER CLAMP LOAD IS ACHIEVED**

**TENSION CONTROL (OEM)**

www.safholland.us  
Copyright © 2018 • SAF-HOLLAND®, Inc.

### 3. CBu/CBXu Model Identification

The CBu/CBXu suspension serial tag is located on the frame bracket (**Figure 6**).

**NOTE:** If the suspension serial tag is NOT legible or is NOT available, it can be identified by the appearance of the equalizing beam. The CBu/CBXu model will have a cast beam with a lower air spring mounting plate welded to it (**Figure 6**).

**NOTE:** This manual applies to the suspension models listed on the front cover. However, determine the specific model number, write that information below and refer to it when obtaining information or replacement parts (**Figure 7**).

**NOTE:** CBu comes with the standard 5" diameter axle and the CBXu comes with the premium 5.75" diameter axle (**Figure 8**).

Figure 6

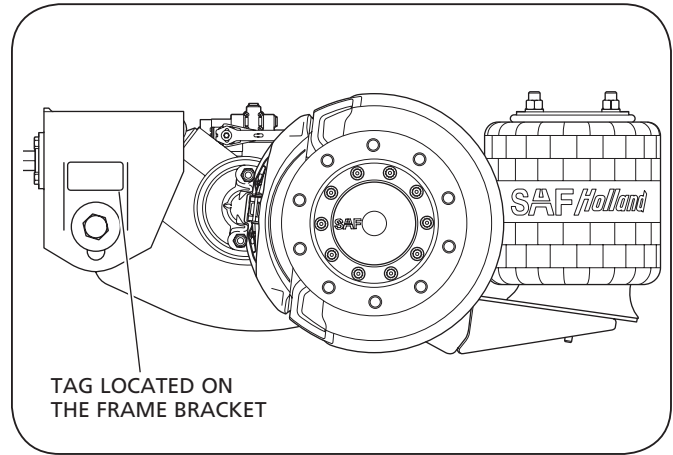

### 4. CBu/CBXu Model Nomenclature

The sample tag illustrated will help interpret the information on the SAF-HOLLAND®, Inc. serial number tag. The part number is on the first line. The model number along with the suspension capacity are on the second line. The third line contains the serial number (**Figure 7**).

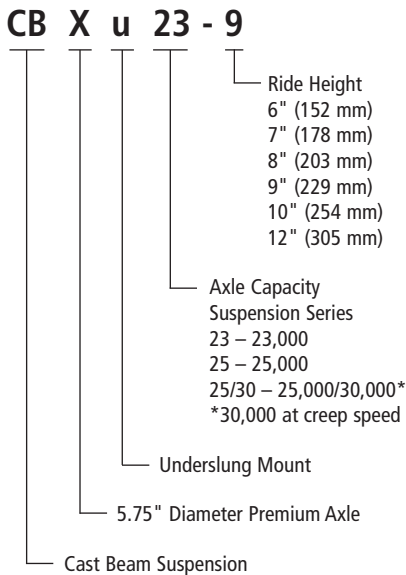

Figure 7

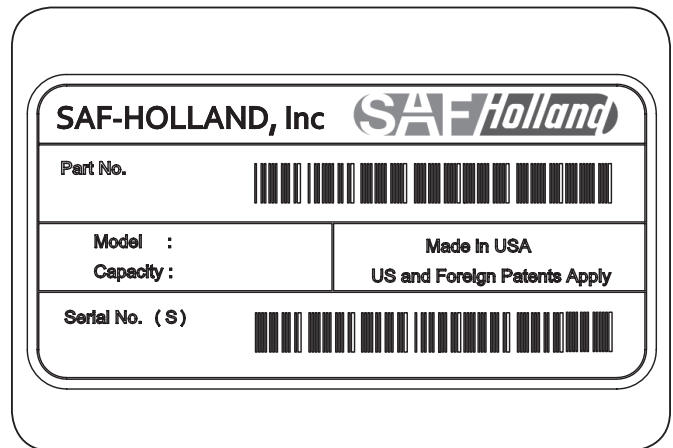
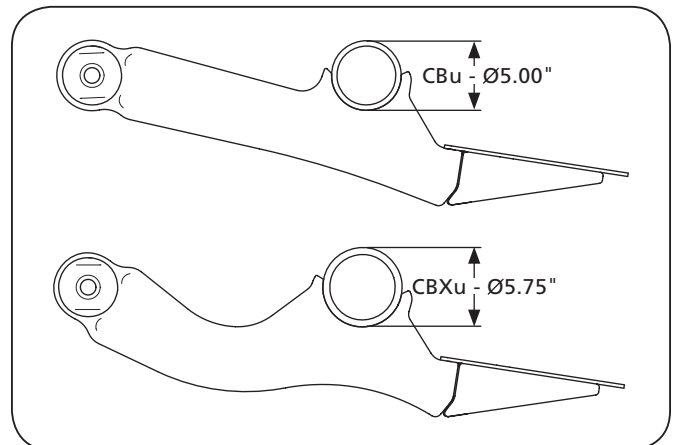

Figure 8



## 5. CBy/CBXy Model Identification

The CBy/CBXy suspension serial tag is located on the inner gusset of the roadside beam (**Figure 9**).

**NOTE:** If the suspension serial tag is NOT legible or is NOT available, it can be identified by the appearance of the equalizing beam. The CBy/CBXy model will have a cast beam with a lower air spring mounting plate welded to it (**Figure 9**).

**NOTE:** This manual applies to the suspension models listed on the front cover. However, determine the specific model number, write that information below and refer to it when obtaining information or replacement parts (**Figure 10**).

Figure 9

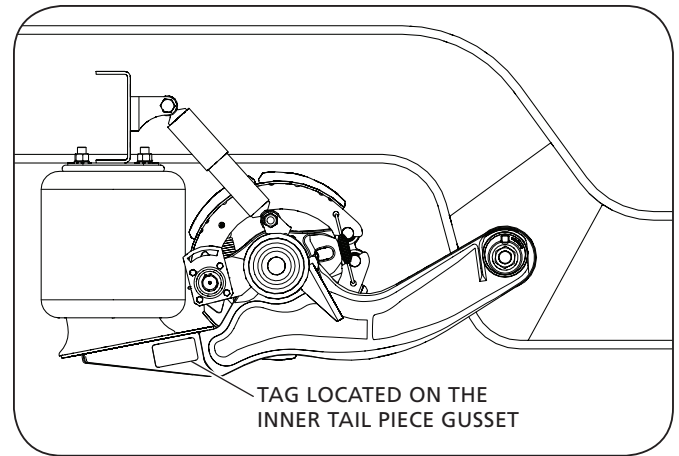

## 6. CBy/CBXy Model Nomenclature

The sample tag illustrated will help interpret the information on the SAF-HOLLAND®, Inc. serial number tag. The part number is on the first line. The model number along with the suspension capacity are on the second line. The third line contains the serial number (**Figure 10**).

Figure 10

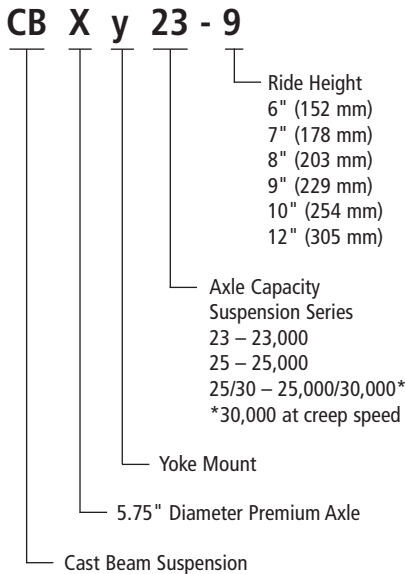
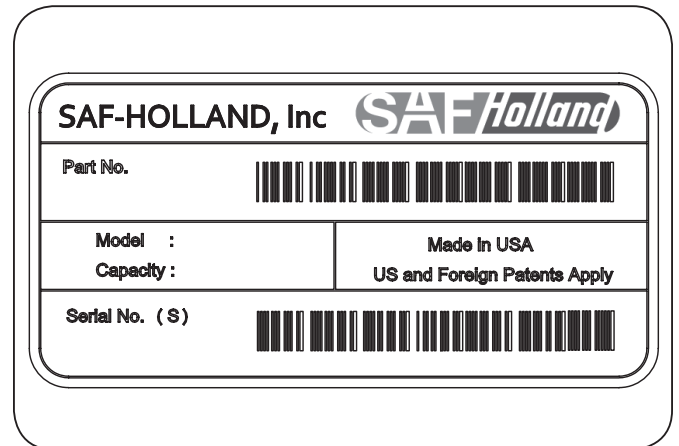

## 7. Welding Standards

### 7.1 Scope

When welding is required for the suspension repairs, observe the requirements below. This specification applies to all components supplied by SAF-HOLLAND®, and its products. The customer assumes all responsibility for weld integrity if weld material and procedure differ from those listed below.

### 7.2 Workmanship

All welding on SAF-HOLLAND® products MUST be performed by a welder qualified according to the appropriate AWS standard for the weld being made or an equivalent standard. It is the responsibility of the customer to provide good workmanship when welding on SAF-HOLLAND® products.

### 7.3 Material

Items to be welded that are made from low carbon or high-strength alloy steel are to be welded with AWS filler metal specification AWS A5.18, filler metal classification ER-70S-3, ER-70S-6 or equivalent unless specified on the installation drawing.

**NOTE:** Any substitution for filler material from the above standard must comply, as a minimum, with the following mechanical properties:

Tensile Strength - 72k psi (496 MPa)  
 Yield Strength - 60k psi (414 MPa)  
 Charpy V Notch - 20 ft.-lbs. (27 N•m) at 0°F (-17.7°C)  
 % Elongation - 22%

The recommended welding gas for gas metal arc welding (GMAW) is 90% Argon / 10% CO<sub>2</sub>. If a different gas is used, welds MUST comply with penetration requirements illustrated (**Figure 11**). Where the installation drawing specifies different than above, the drawing shall prevail.

### 7.4 Procedures

Tack welds used for positioning components are to be located in the center of the final weld, where practical. Tack weld should be completely fused to the finish weld. DO NOT break arc at the end of the weld. Back up all finish welds at least 1/2" (12.7 mm) or a sufficient amount to prevent craters at the end of the weld. Where weld is illustrated to go around corners, it is assumed the corner represents a stress concentration area. DO NOT start or stop weld within 1" (25.4 mm) of the corner. Particular care should be taken to prevent undercutting in this area.

### 7.5 Weld Size

If weld size is not specified, the effective throat of the weld MUST be no smaller than the thinnest material being welded (**Figure 11**).

**Figure 11**

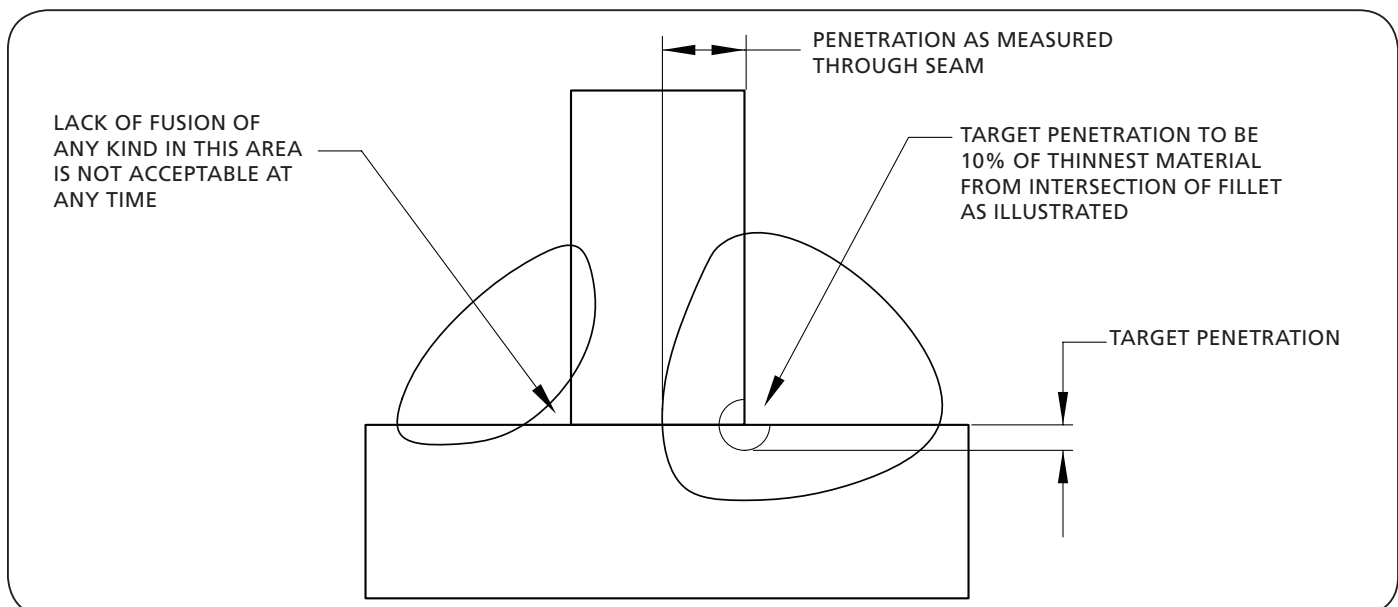



## 8. Standard Air Control System Installation

The following is a typical air system installation and should be plumbed as illustrated (**Figure 12**). Optional air control systems are available. Contact SAF-HOLLAND® applications department to discuss particular needs.

The air control system of the CBU/CBXu and CBy/CBXy suspensions use air drawn from the tractor air system to pressurize the suspension's air springs. The suspension, working with the air control system, provides optimum suspension performance only when all air control system components are installed and operating properly.

**IMPORTANT:** Make certain that all air lines and valves are free from obstruction through the full operational range of the suspension.

**IMPORTANT:** A pressure protection valve (PPV) must be attached to the air reservoir in order to maintain proper air pressure (**Figure 12**).

**IMPORTANT:** The air pressure protection valve maintains safe brake pressure. Approximately 85 psig (5.9 bars) opens the valve, and 65 psig (4.5 bars) closes the valve.

**NOTE:** When installing pressure protection valve, use a drop of oil or Loctite® to lubricate threaded connections. DO NOT use a pipe compound or teflon tape as it could clog the valve.

A height control valve (HCV) is used to regulate the air pressure required for varying load capacities (**Figure 12**).

Figure 12

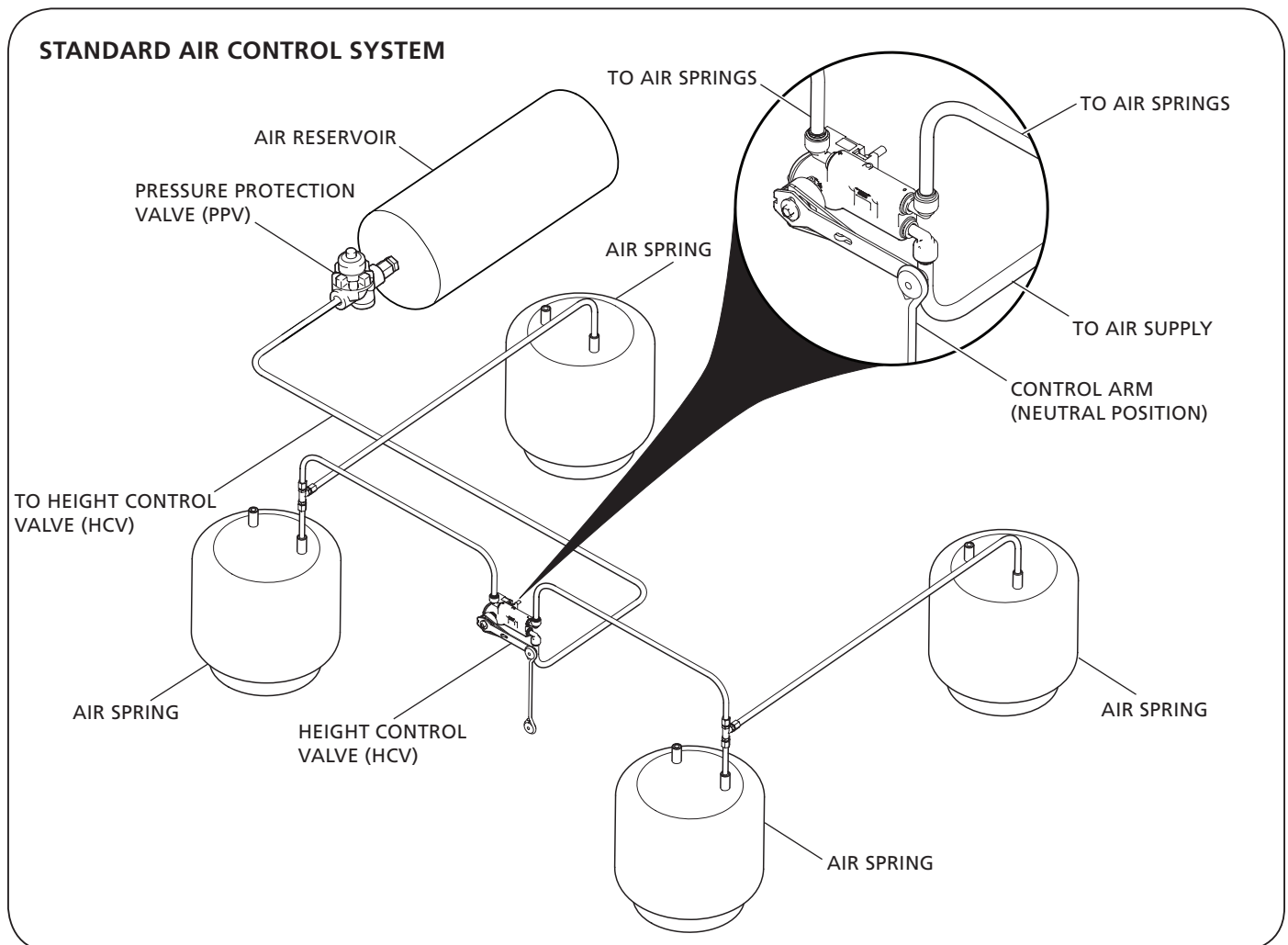

## 9. Suspension Assembly Installation

**NOTE:** Locate the suspension on the trailer frame. Refer to the model's specific installation drawing for the proper weld patterns and locations. To obtain a copy of the specific installation drawing, contact SAF-HOLLAND® Customer Service at 888-396-6501.

1. Once the suspension is correctly positioned, weld the suspension in place as outlined in Section 7.
2. Ensure the linkage assembled to the height control valve (HCV) and suspension is installed properly (**Figure 13**).
3. Install service and emergency lines to the suspension and allow the suspension to air up.
6. Measure the ride height of the suspension with a tape measure (**Figure 14**).
7. Compare the measured suspension ride height value to the appropriate value in (**Table 1**). Ensure the measured ride height value is within  $\pm 1/4"$  (6 mm).

**IMPORTANT:** If the measured ride height value is NOT within  $\pm 1/4"$  (6 mm), follow the Ride Height Adjustment procedures described in Section 10.

**Table 1**

MODEL		"A" RIDE HEIGHT
CBu/CBXu-6	CBy/CBXy-6	6"
CBu/CBXu-7	CBy/CBXy-7	7"
CBu/CBXu-8	CBy/CBXy-8	8"
CBu/CBXu-9	CBy/CBXy-9	9"
CBu/CBXu-10	CBy/CBXy-10	10"
CBu/CBXu-12	CBy/CBXy-12	12"

8. Visually check all air control system fittings for air leaks by applying a soapy water solution and checking for bubbles at all air connections and fittings.

**Figure 13**

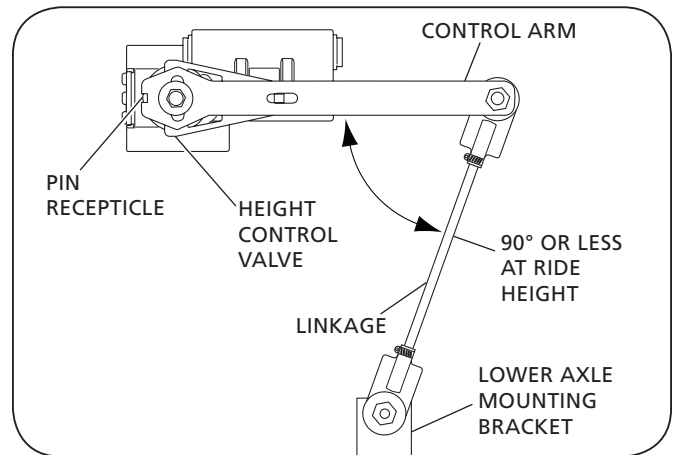

**Figure 14**

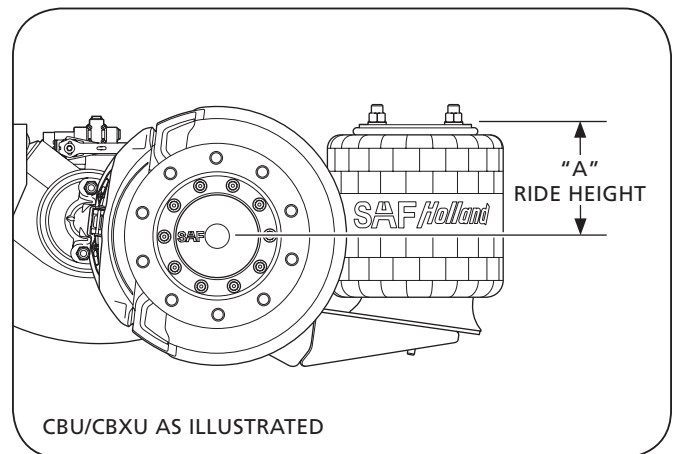

## 10. Ride Height Adjustment

**NOTE:** Yoke mount suspensions DO NOT receive a height control valve.

**IMPORTANT:** Trailer MUST be unloaded before beginning any service procedures.

1. On a level surface, support the front of the trailer with either a kingpin stand, landing gear, or while coupled to a tractor (**Figure 15**).
2. Raise the trailer frame approximately 2" (51 mm) above the suspension's specified ride height (**Figure 16**).
3. Place multiple jack stands at the suspension's specified ride height (**Table 1**) under the vehicle frame at OEM specified locations, then lower the trailer onto the jack stands.

**NOTE:** It could be necessary to shim jack stands to achieve specified ride height.

**⚠ WARNING** Failure to properly support the suspension during maintenance could create a crush hazard which, if not avoided, could result in death or serious injury.

**Table 2**

MODEL	"A" RIDE HEIGHT
CBu/CBXu-6	6"
CBu/CBXu-7	7"
CBu/CBXu-8	8"
CBu/CBXu-9	9"
CBu/CBXu-10	10"
CBu/CBXu-12	12"

4. Exhaust all air from the suspension, set parking brakes, and chock the wheels.

**⚠ WARNING** Failure to exhaust the suspension air and chock the tires prior to beginning maintenance could allow vehicle movement which, if not avoided, could result in death or serious injury.

5. Disconnect the linkage from the control arm and lower axle mounting bracket (**Figure 17**).
6. Pin the height control valve so that the valve arm is in the center or neutral position (**Figure 17**).

**Figure 15**

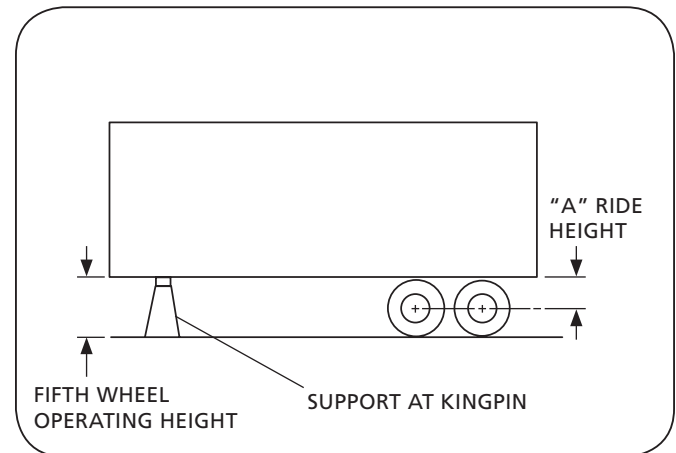

**Figure 16**

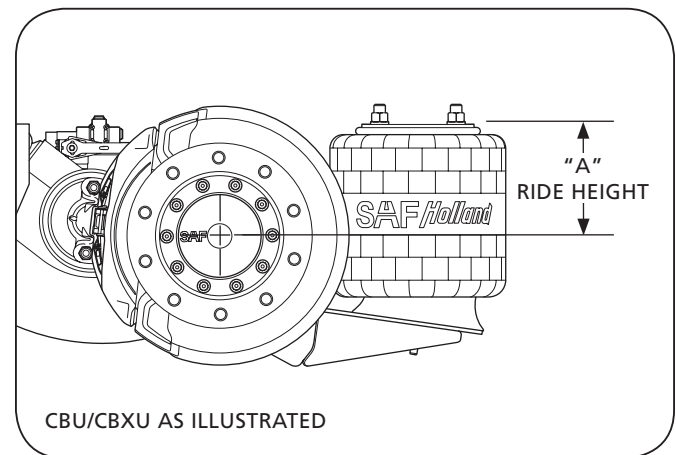

**Figure 17**

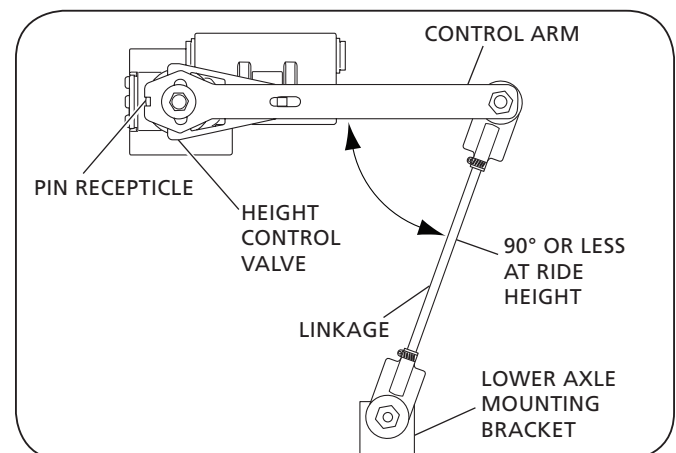

7. Measure distance "B" between the valve arm and mounting bracket holes to determine linkage length (**Figure 18**).
8. Adjust linkage to required length and install the hardware into the upper and lower connections (**Figure 18**). Torque hardware to 30-40 in.-lbs. (3-4 N•m).

**NOTE:** It could be necessary to cut linkage rod to achieve proper length. Be sure to de-burr rod to prevent link end damage.

9. Raise the trailer approximately 2" (50 mm) above ride height and remove jack stands.
10. Slowly lower the trailer so that the trailer suspension is fully collapsed.
11. Pull pin and apply air to trailer allowing the suspension to return to ride height.
12. With the suspension at rest, measure the ride height. Ride height **MUST** be within 1/4" (6 mm) of the suspensions specified ride height.
13. Spray a soapy water mix on all air line connections to check for air leaks and verify fittings are tight.

**IMPORTANT:** It is the responsibility of the air system installer to secure all air lines and check for air leaks. If air leaks are detected, repair as required.

**CAUTION** Failure to eliminate air leaks could compromise the suspension performance which, if not avoided, could result in component or property damage.

14. Remove the wheel chocks.

**Figure 18**

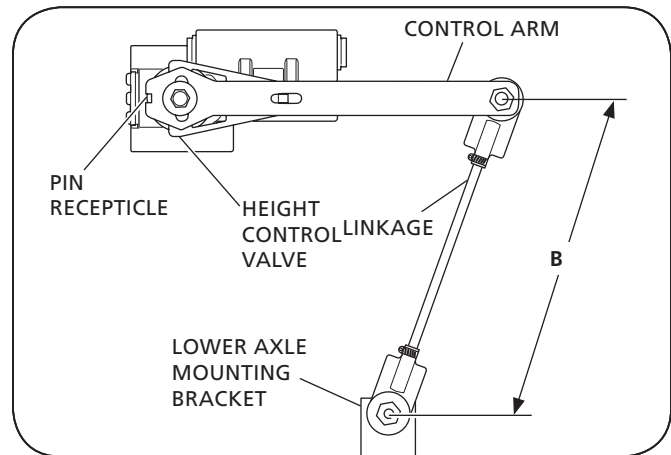

## 11. SwingAlign™ Axle Alignment

### 11.1 Alignment Preparation

1. Pull the trailer in a straight line for a sufficient distance to ensure there are no binds in the suspension.
2. Disengage the trailer parking brakes and make sure the trailer is empty.
3. Manually measure or use an optical device specifically designed for alignment measuring to determine the following:
  - a. Measure the distance from the king pin to the centerline of the front axle spindles. It is recommended that spindle extensions be utilized.
  - b. Dimensions A and B (**Figure 19**) MUST be equal to within 1/8" (3 mm).
  - c. Measure the distance from the centerline of the front axle spindles to the centerline of the rear axle spindles.
  - d. Dimensions C and D (**Figure 19**) MUST be equal to within 1/16" (1 mm).

### 11.2 Alignment Instructions

1. Using the measurements from Step 3, align each axle. Align by rotating the alignment bolt head using a 1-3/8" socket wrench on the front face of the roadside frame bracket. Rotate clockwise to move axle forward (**A arrows**); counterclockwise to move axle rearward (**B arrows**) (**Figure 20**). Approximately 250 ft.-lbs. (339 N•m) will be required.

**IMPORTANT:** DO NOT loosen the pivot bolts.

**IMPORTANT:** Two (2) scribe lines on the side of the frame bracket indicate maximum adjustment for axle alignment. If the edge of the visible washer touches either scribe line, the SwingAlign™ axle alignment adjustment is "out of stroke." Inspect and repair trailer components as necessary and realign (**Figure 21**).

**IMPORTANT:** The SwingAlign™ design maintains proper alignment without welding or without loosening of the pivot connection. DO NOT weld alignment bolt or pivot bolts (**Figure 21**). If connection requires tightening, refer to Section 15 Torque Specifications.

**Figure 19**

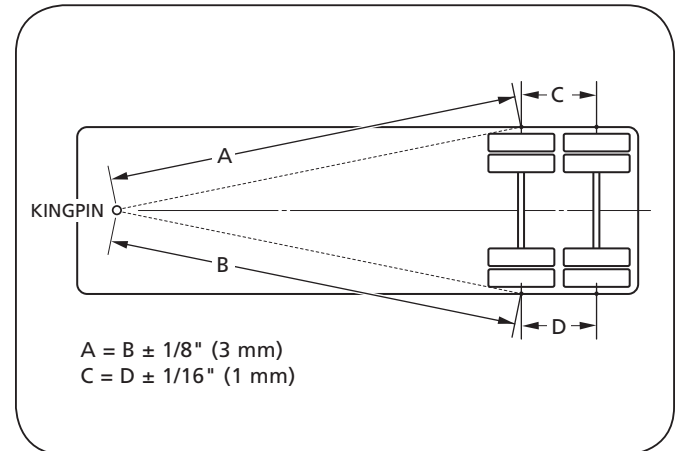

**Figure 20**

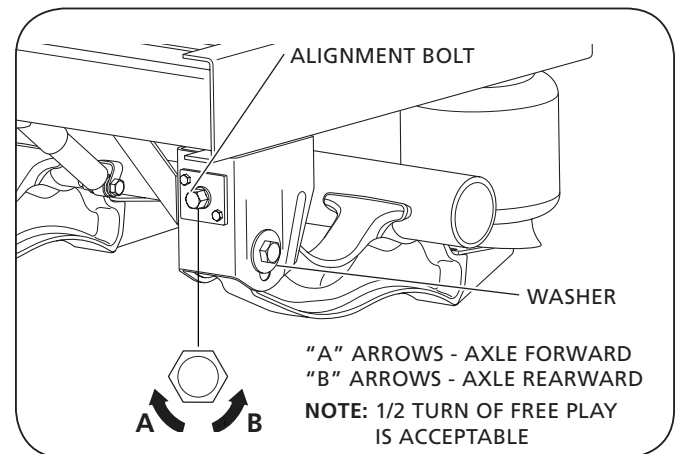

**Figure 21**

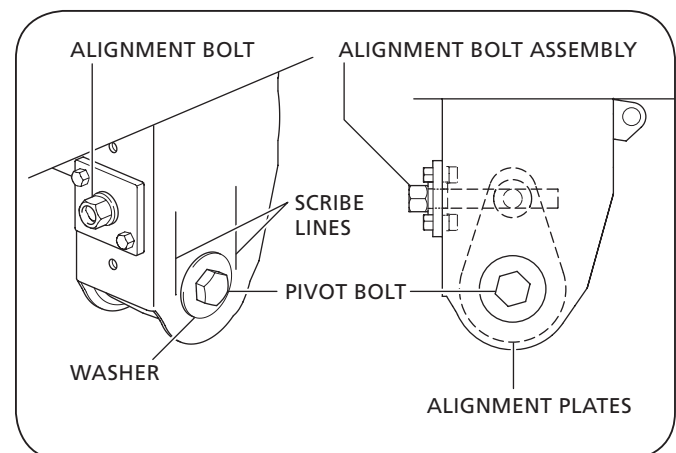

## 12. CBy/CBx Axle Alignment and Adjustment

### 12.1 Essentric Alignment Collars

The CBy/CBx suspension assemblies use four (4) essentric style alignment collars in the pivot assembly. There are two (2) in the roadside pivot assembly and two (2) on the curbside assembly. The collars allow the suspension beam to be adjusted for proper axle alignment using two (2) 1/2" drive ratchet style wrenches (**Figure 22**).

**NOTE:** The 1/2" drive hole should be positioned to be above the bolt hole in all instances when installed properly.

### 12.2 Alignment Descriptions

Fixed Side of Suspension:

The Curbside pivot hardware is considered the "fixed" side of the suspension alignment system.

Adjustable Side of Suspension:

The Roadside pivot hardware is considered the "adjustable" side of the suspension alignment system.

### 12.3 Adjustment Procedure

1. Set the "fixed" side of the suspension:

- a. To set the fixed side of the suspension, use two (2) 1/2" drive ratchet style wrenches (one on both sides of pivot assembly, inboard and outboard). Adjust the collars by placing the ratchet wrenches into the 1/2" square hole of the alignment collars and turning simultaneously in one direction, frontward to move the axle forward (**Figure 23 Arrow A**) and rearward to move the axle backward (**Figure 23 Arrow B**).

**NOTE:** There is .5" (13mm) of total allowable axle adjustment: .25" (6mm) forward and .25" (6mm) rearward.

**NOTE:** Improper bolt alignment and binding will occur if collars are NOT inline with each other on both sides of the cast beam. Collars will NOT be seated properly and applied torque will NOT hold (**Figure 24**).

**Figure 22**

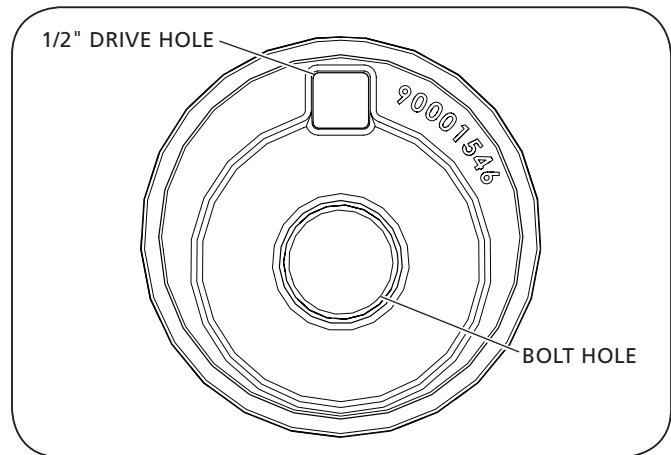

**Figure 23**

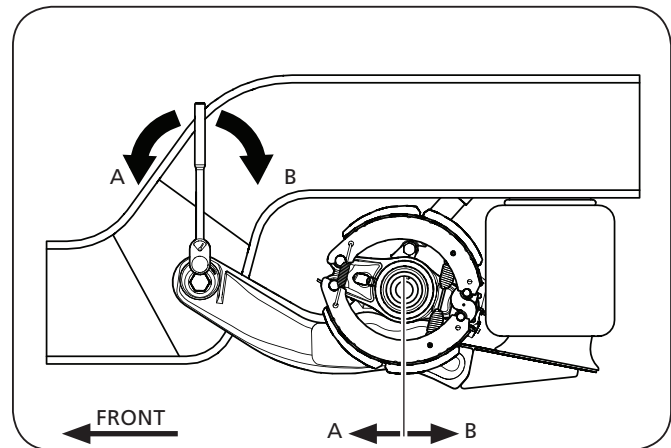

**Figure 24**

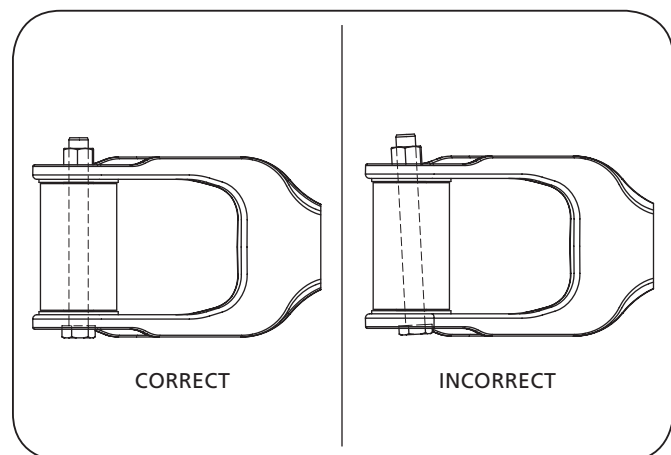

- b. The collars should be centered with equal distance between the alignment tabs on the cast beam and the square ratchet on the collar itself. The pivot assembly is then in it's "centermost" position (**Figure 25**).
- c. Once the fixed side assembly is in it's centermost position, the nut should be torqued to SAF-HOLLAND® provided torque specifications Section 15.

**NOTE:** Applying torque to the nut will cause the alignment collars to rotate. Use 1/2" drive ratchet wrench to resist rotation while tightening pivot nut.

2. Set the "adjustable" side of the suspension:
  - a. Using the same procedure outlined above in Step 1.a, the roadside pivot assembly should be adjusted until the desired axle alignment is reached.

**NOTE:** If axle alignment cannot be achieved within the allowable adjustable distance from the roadside (adjustable) pivot assembly, the curbside (fixed) assembly can be adjusted to make up the difference needed to achieve proper alignment.

- b. Once the adjustable side assembly is in it's centermost position, the nut should be torqued to SAF-HOLLAND® provided torque specifications Section 15.

**IMPORTANT:** DO NOT weld any components of the pivot assembly.

### 13. Brake Adjustment Instructions

The brakes should be adjusted per axle and brake manufacturer's specifications.

For the CBu/CBXu and CBy/CBXy Suspensions with Drum Brake Systems refer to SAF-HOLLAND® Drum Brake Service Manual XL-TA10006OM. Drum Brakes can be on a 5" or 5.75" axle.

For CBXu and CBXy Suspensions with Disc Brake Systems refer to SAF-HOLLAND® Disc Brake Service Manual XL-SA10059OM. Disc Brakes are on the 5.75" axle.

**Figure 25**

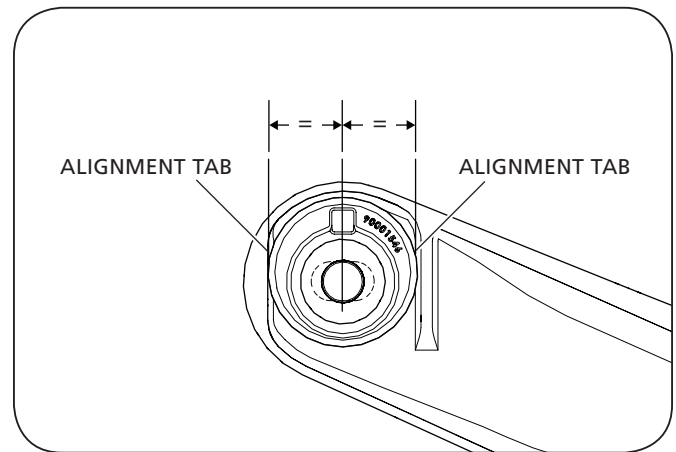

## 14. Pre-Operation

**NOTE:** In the United States, workshop safety requirements are defined by federal and/or state Occupational Safety and Health Act. Equivalent laws could exist in other countries. This manual is written based on the assumption that OSHA or other applicable employee safety regulations are followed by the location where work is performed.

1. With the vehicle on a level surface, bring air system to operating pressure (above 85 psig/5.9 bars).
2. Shut off the vehicle and visually check all air control system fittings for air leaks by applying a soapy water solution and checking for bubbles at all air connections and fittings. Examine the air springs (**Figure 25**) for equal firmness.
3. Check the shock absorbers for proper installation and make sure that the upper and lower 3/4" shock absorber nuts are torqued to 140-175 ft.-lbs. (190-237 N•m) (**Figure 26**).
4. Verify that the 1/2" air spring mounting nuts are torqued to 30-40 ft.-lbs. (41-54 N•m), and the 3/4" air spring mounting nuts are torqued to 40-45 ft.-lbs. (54-61 N•m) (**Figure 26**).

5. With the suspension at full capacity, check that there is a 1" (25 mm) minimum clearance around the air springs.
6. The suspension's ride height should be within  $\pm 1/4$ " (6 mm) of the recommended design height. For proper ride height, refer to Section 11.
7. Determine which pivot bolt style is installed (**Figure 26**).
  - If 1-1/8" hex head bolt, verify torque on the nut is 550-600 ft.-lbs. (746-813 N•m).
  - If 7/8" pan head shear bolt, verify spline has been sheared off.

**IMPORTANT:** The SwingAlign™ design maintains proper alignment under correct torque without welding; DO NOT weld (**Figure 26**).

**NOTE:** SwingAlign™ pivot connections are on roadside and fixed alignment pivot connections are on curbside. For SwingAlign™ Connection Axle Alignment procedure, refer to Section 9.

**Figure 26**

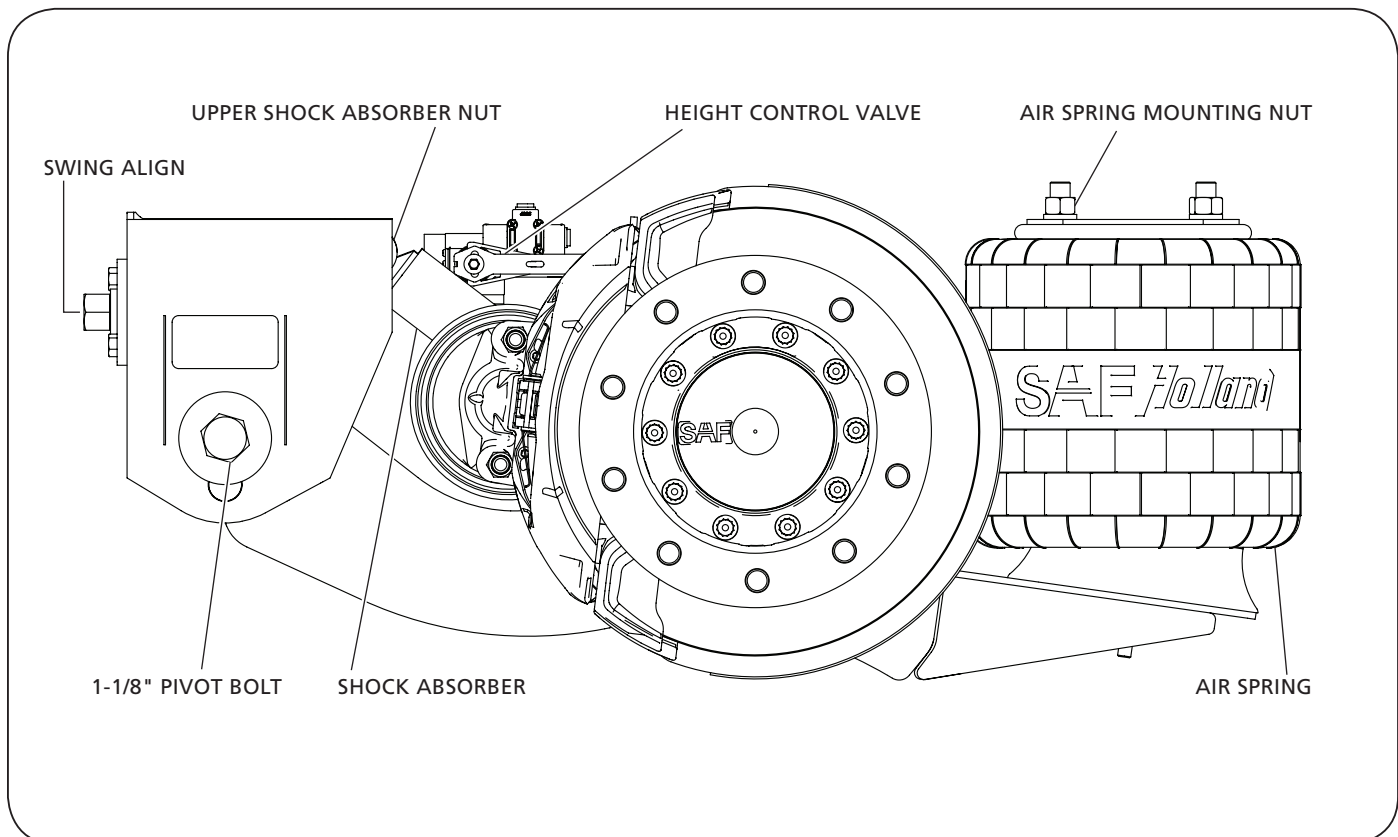



## 15. Torque Specifications

Table 3

COMPONENT	TORQUE VALUE	FASTENER SIZE
Shock Absorber	140-175 ft.-lbs. 190-237 N•m	3/4"
Pivot Connection, Hex Head Bolt	550-600 ft.-lbs. 746-813 N•m	1-1/8"
*Pivot Connection, Pan Head Shear Bolt	Visual Inspection	7/8"
Lower Air Spring Nut	30-40 ft.-lbs. 40-54 N•m	1/2"
Upper Air Spring Nut	40-45 ft.-lbs. 54-61 N•m	3/4"
SwingAlign Mounting Fasteners Only - NOT Pivot Bolt	50-60 ft.-lbs. 68-81 N•m	1/2"
Height Control Valve Lower Linkage	30-40 In.-lbs. 3-5 N•m	1/4"

All torque specifications are  $\pm 5\%$ .  
 Torques specified are for clean, lubricated threads.  
 Always Apply torque to nut if possible.  
 Required re-torquing at every brake re-lining.  
 \* If equipped with 7/8" pan head shear bolt, ensure that the spline is sheared off and that there are no signs of movement.

**NOTE:** Torque specifications listed above are with clean lubricated / coated threads (**Table 3**). All new SAF-HOLLAND fasteners come pre-coated from the factory. For bolt and lock nut grade markings refer to **Figure 27**.

**IMPORTANT:** The use of special lubricants with friction modifiers, such as Anti-Seize or Never-Seez®, without written approval from SAF-HOLLAND engineering, will void warranty and could lead to over torquing of fasteners or other component issues.

### General Information

- The torque specifications are applied to the nut and NOT the bolt.

**⚠ WARNING** Failure to use the proper fasteners when servicing the suspension could cause component failure which, if not avoided, could result in death or serious injury.

**⚠ WARNING** Failure to properly torque all fasteners could result in component failure which, if not avoided, could result in death or serious injury.

Figure 27

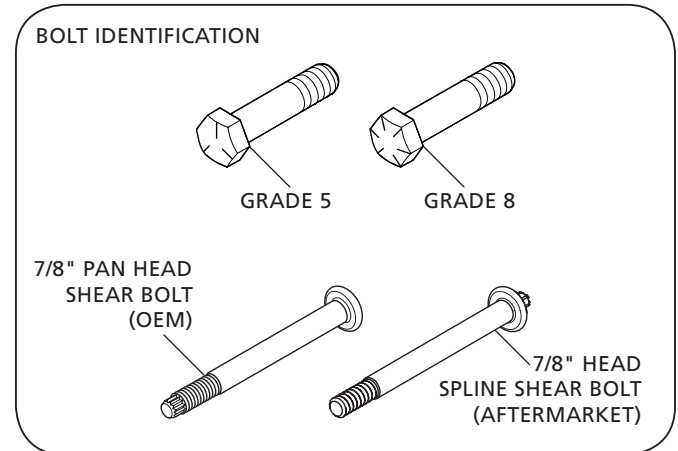

## 16. Routine Maintenance and Daily Inspection

1. Daily or before each trip, check the suspension to be sure it is fully operational.
2. Inspect all decals to ensure they are clearly legible and intact. Clean with a terry cloth towel, soap and water.
3. Visually inspect air springs for sufficient inflation and that the suspension is at proper ride height. For ride height details and measurements, refer to Section 10 of this manual.

### 16.1 Initial Three (3) Months or 5,000 Mile (8,000 km) Service Inspection

1. Suspension ride height (underside of frame to centerline of axle) **MUST** be within  $\pm 1/4"$  (6 mm) of recommended design height. For instructions on measuring ride height, refer to Section 7.

**CAUTION**

An improperly set ride height could result in suspension component damage and/or poor vehicle ride performance.

2. After first three (3) months or 5,000 miles (8,000 km) of service, whichever comes first, inspect bolts and nuts at the pivot connections to ensure there are no signs of movement. Check all other nuts and bolts for proper torque, refer to the specifications listed in Section 15. Re-torque as necessary thereafter.
3. With the vehicle on a level surface and air pressure above 85 psig (5.9 bars), verify that all air springs are of sufficient and equal firmness.

**NOTE:** Check all air control system fittings for air leaks, by applying a soapy water solution and checking for bubbles at all air connections and fittings.

### 16.2 Routine Physical Inspections

Every 100,000 Miles (160,000 km) or one (1) year, whichever comes first.

Check all other suspension components for any sign of damage, looseness, torque loss, wear or cracks. Repair, tighten or replace damaged part(s) to prevent equipment breakdown.

### 16.3 Visual Inspection Procedure

**IMPORTANT:** A schedule for physical and visual inspections should be established by the operator based on severity of operation or damage to the vehicle could occur.

**IMPORTANT:** During each pretrip and safety inspection of the vehicle, a visual inspection of the suspension should be done or damage to the vehicle could occur.

Visually check for:

- Loose, broken or missing fasteners. Repair or replace as needed.

**WARNING**

Loose, damaged, or missing fasteners can cause loss of vehicle control which, if not avoided, could result in death or serious injury.

- Air springs – clearances, wear damage, and proper inflation.
- Shock absorbers – leaking or damaged.
- Cracked parts or welds.





From fifth wheel rebuild kits to suspension bushing repair kits, SAF-HOLLAND Original Parts are the same quality components used in the original component assembly.

SAF-HOLLAND Original Parts are tested and designed to provide maximum performance and durability. Will-fits, look-alikes or, worse yet, counterfeit parts will only limit the performance potential and could possibly void SAF-HOLLAND's warranty. Always be sure to spec SAF-HOLLAND Original Parts when servicing your SAF-HOLLAND product.

**SAF-HOLLAND USA • 888.396.6501 • Fax 800.356.3929**  
[www.safholland.us](http://www.safholland.us)

**SAF-HOLLAND CANADA • 519.537.3494 • Fax 800.565.7753**  
**WESTERN CANADA • 604.574.7491 • Fax 604.574.0244**  
[www.safholland.ca](http://www.safholland.ca)

**SAF-HOLLAND MEXICO • 52.55.5362.8743 • Fax 52.55.5362.8743**  
[www.safholland.com.mx](http://www.safholland.com.mx)

[info@safholland.com](mailto:info@safholland.com)