

Important Information Sliding Series Suspension

Pivot Connection Design Improvement

June 2018

SAF-HOLLAND® is pleased to introduce an improved pivot connection design that will be incorporated on all sliding air ride suspensions. This new connection features a specially designed tension controlled (TC) fastener that eliminates the need for periodic mechanical torque inspections.

The improved pivot connection design incorporates a 7/8" diameter tension controlled bolt with precision collars that extend into the pivot bushing core. This new design increases fastener stretch while retaining the same shear area as the previous generation 1-1/8" design. Additionally, the TC fastener has a shear end design that provides positive visual proof that the proper clamp load was achieved during assembly.

This new pivot connection system will be used on all sliding air ride suspension manufactured after JULY 15, 2018.

The new pivot connection design is specially designed to maintain clamp load over the life of the suspension. This eliminates the need to re-torque the connection at regular intervals. SAF-HOLLAND recommends that the connection be cleaned and inspected for signs of movement during every PM cycle. New style pivot connections do not need to be removed for axle alignment.

Retro-fit kits are available to convert older generation pivot connections to the new design:

- CBX without PosiLift: 48100697
- CBX with PosiLift: 11005217
- CBXA with or without PosiLift: 48100700

If you have any questions or require additional product assistance, please contact your SAF-HOLLAND sales or service representative at (888) 396-6501 or visit our website at www.safholland.us.

Old Style

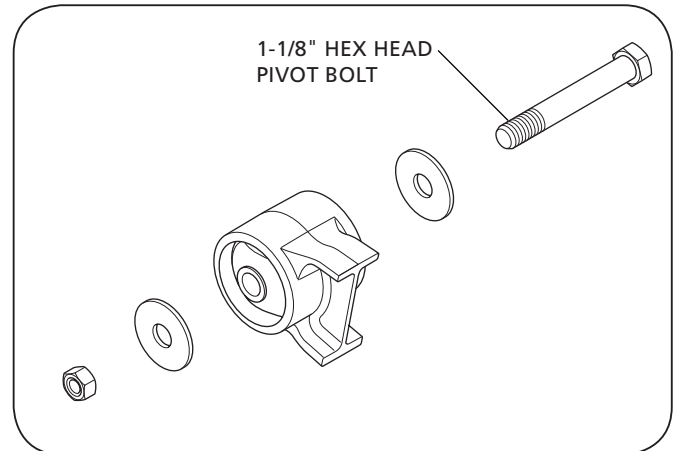

Factory Installed

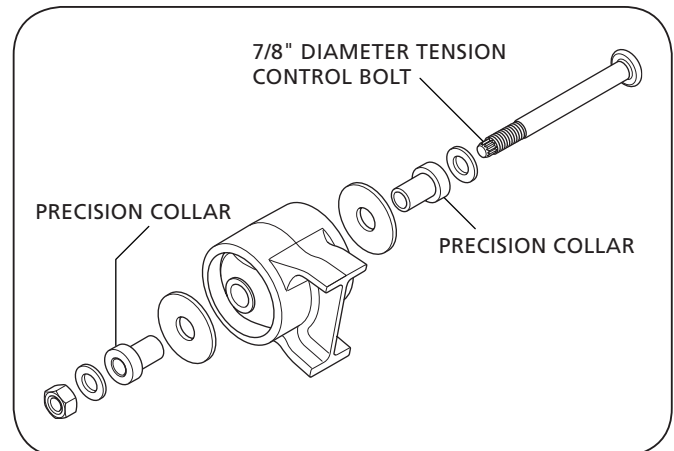

After Market

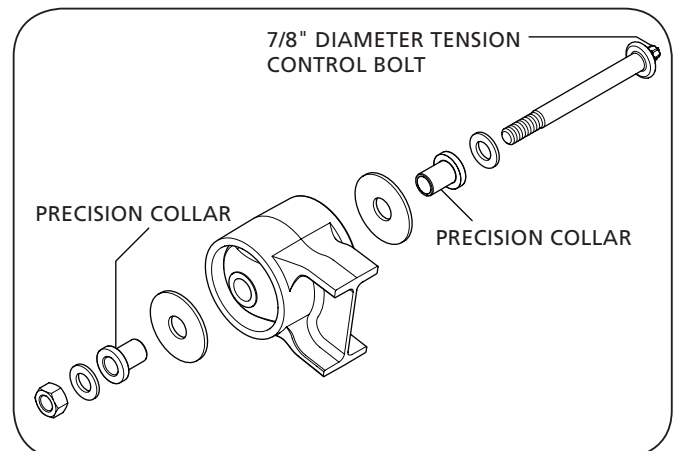



From fifth wheel rebuild kits to suspension bushing repair kits, SAF-HOLLAND Original Parts are the same quality components used in the original component assembly.

SAF-HOLLAND Original Parts are tested and designed to provide maximum performance and durability. Will-fits, look-alikes or, worse yet, counterfeit parts will only limit the performance potential and could possibly void SAF-HOLLAND's warranty. Always be sure to spec

SAF-HOLLAND Original Parts when servicing your SAF-HOLLAND product.

SAF-HOLLAND USA • 888.396.6501 • Fax 800.356.3929
www.safholland.us

SAF-HOLLAND CANADA • 519.537.3494 • Fax 800.565.7753
WESTERN CANADA • 604.574.7491 • Fax 604.574.0244
www.safholland.ca

SAF-HOLLAND MEXICO • 52.55.5362.8743 • Fax 52.55.5362.8743
www.safholland.com.mx

info@safholland.com