



FW35TT™

THE STRONGEST, FASTEST AND MOST RELIABLE
TERMINAL TRACTOR FIFTH WHEEL



FWB5TT™

TERMINAL TRACTOR FIFTH WHEEL

MORE DURABLE
EASIER TO MAINTAIN
FUNCTIONALLY SUPERIOR

1 Strategically Strength Enhanced Rib Structure

The main rib has been beefed up and additional ribs are built into the kingpin throat area. The bridge is made stronger with increased thickness and strategically located gussets.

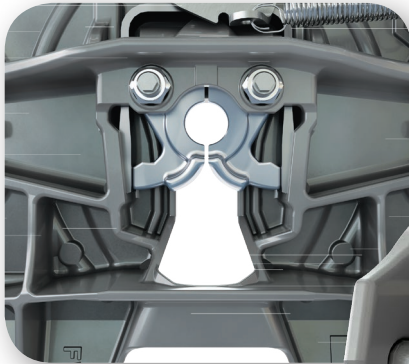

2 80,000 lbs. Capacity Top Plate

Top plate is cast with higher strength steel alloy with an increased top plate thickness for long life performance.



3 Easy Lock Set Replacement

Easy 15 minute lock set replacement – “Slip-Fit” lock pins with lock nut retention for easy and quick removal. Locks now slide out as a complete set for easy lock-only replacement.

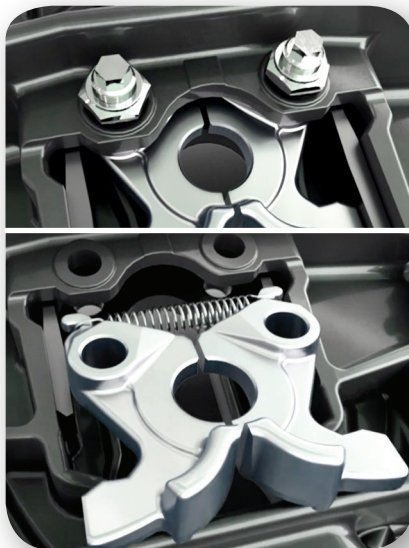

Increased to
80,000 lbs.
CAPACITY
Maximum Vertical Load

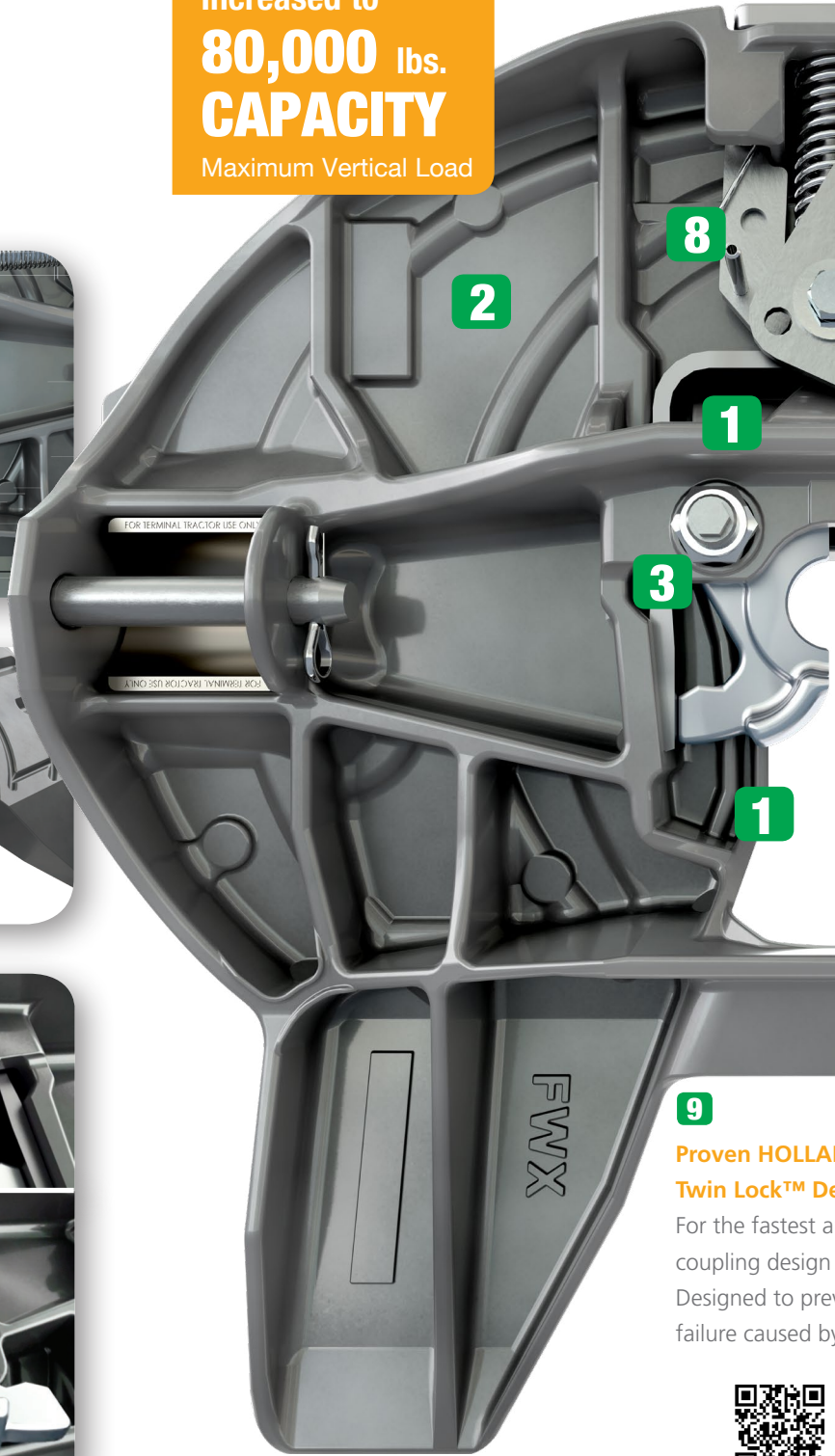

9 Proven HOLLAND Twin Lock™ Design
For the fastest and most secure coupling design.
Designed to prevent failure caused by



THE STRONGEST, FASTEST AND MOST

THE BEST IS EVEN BETTER

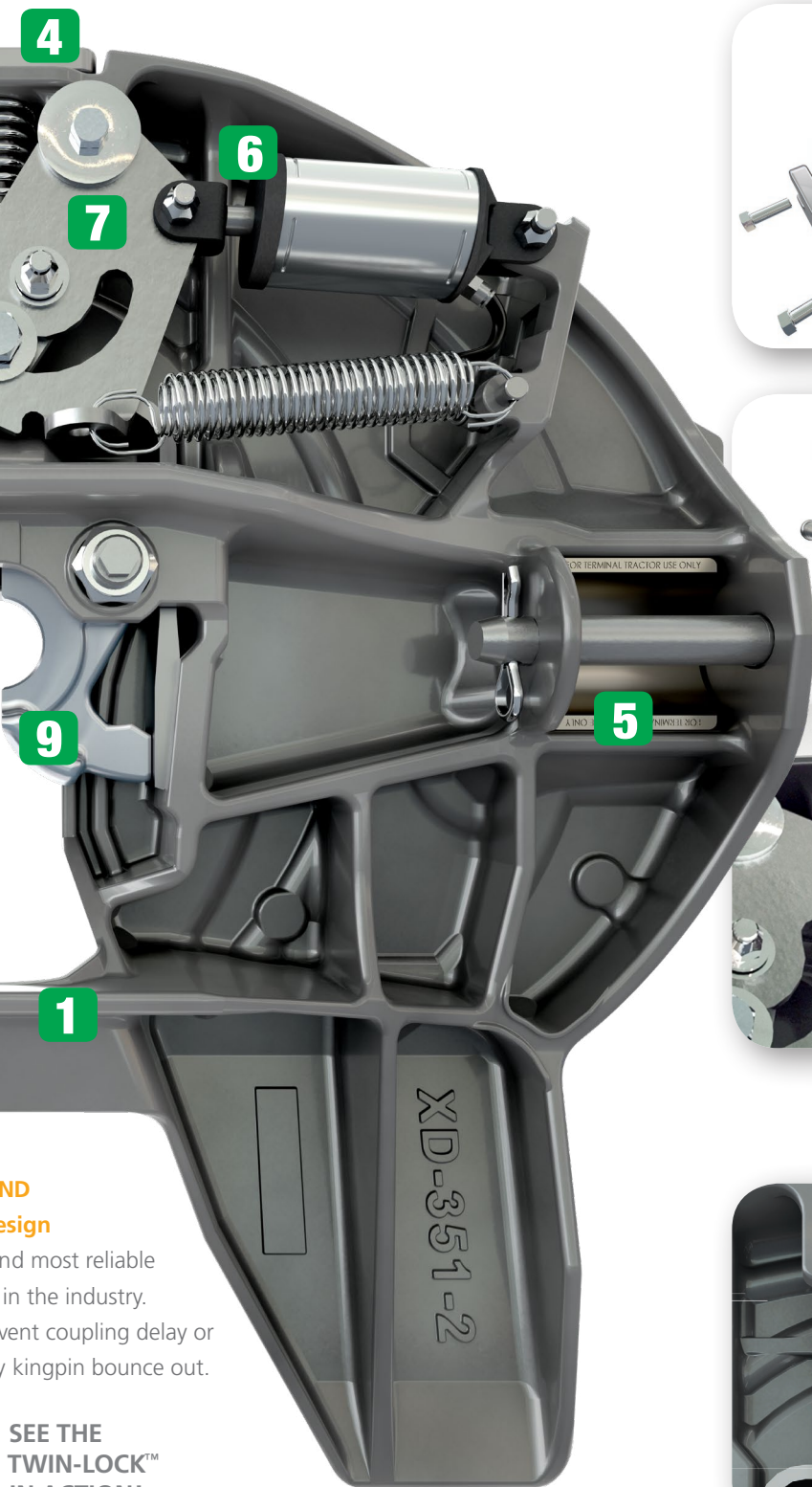

AND
design
and most reliable
in the industry.
prevent coupling delay or
kingpin bounce out.

SEE THE
TWIN-LOCK™
IN ACTION!

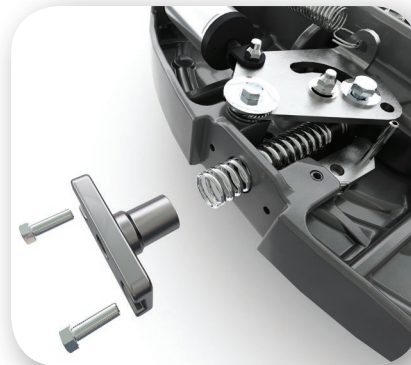

4 Removable Spring Retainer

Makes for quick and easy removal of the yoke shaft spring. No need to compress the spring by hand to install.



5 NoLube Pocket Liners

NoLube Pocket Liner inserts with easy to remove clinch pin for quick and easy replacement. No grinding or tools required to replace pocket liners.

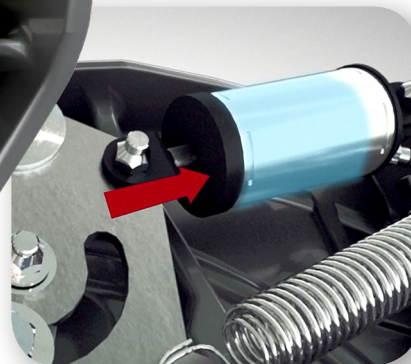

6 Lock-Down Mode for Added Coupling Security

New double acting air cylinder provides a new level of coupling security with an integrated "Lock-Down" mode that is automatically activated when the driver releases the trailer brakes. Prevents the potential for dropped trailers when properly coupled.

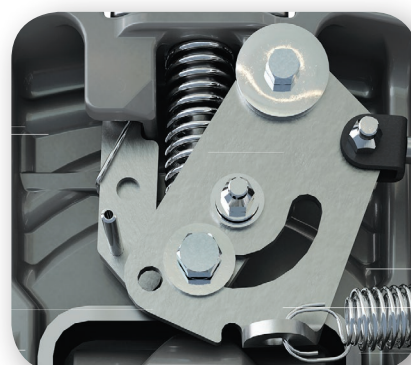

7 Optimized Cam Plate

Engineered for smoother operation throughout the coupling and uncoupling process.

8 Integrated Automotive Secondary Lock

Eliminates the need for a manual handle activated secondary lock.

RELIABLE TERMINAL TRACTOR FIFTH WHEEL

SAF Holland Group



TRAILER AXLES AND
SUSPENSION SYSTEMS



COUPLING AND
LIFTING SYSTEMS



SUSPENSIONS FOR
TRUCKS AND BUSES



SUSPENSIONS AND
AXLE SYSTEMS



BUS AIR SUSPENSION
SYSTEMS



V. ORLANDI
TOWING
SYSTEMS



TRAILER AXLES/SUSPENSIONS,
COUPLING AND LIFTING
SYSTEMS

safholland.com

SAF-HOLLAND, Inc.

888.396.6501 Fax 800.356.3929

SAF-HOLLAND Canada Limited

519.537.3494 Fax 800.565.7753

Western Canada 604.574.7491 Fax 614.574.0244