

SEVERE-DUTY FIFTH WHEEL SLIDER SYSTEM

THE INDUSTRY'S LEADING SEVERE-DUTY SLIDER SYSTEM -
INCLUDES KOMPENSATOR® AND NO-TILT MODELS



SEVERE-DUTY SLIDER SYSTEM FOR HOLLAND FIFTH WHEELS

STANDARD FEATURES

- When combined with the FW70 top plate, it delivers a very robust 200,000 lb. drawbar pull capacity for sliding applications.
- 8", 9", 10" and 11" bracket heights to meet all configuration needs for the OEMs and customers.
- 12", 24", 36", 48", 60" and 72" slider travels to accommodate for a wide range of weight distribution and clearance needs.
- 2" slide increments for positioning versatility to meet any payload distribution requirements.
- In-cab air slide release control allows driver to easily reposition the fifth wheel when required.
- SDS modular design is service friendly to allow the changing of fifth wheel heights or adding an optional convertible No-Tilt top plate.

VISUAL PLUNGER LOCK INDICATORS



Located towards the front of the slide bracket for easy visibility, allows driver to quickly identify that the slide bracket is securely locked in place.

Available Option – Repositionable slide stops are available when there is a need to limit the fifth wheel travel to accommodate the customer application requirements.

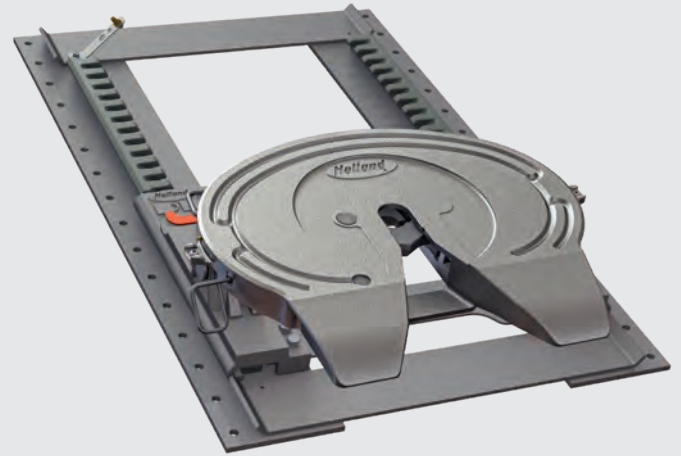

SEVERAL SEVERE-DUTY SLIDER MODELS

Designed to work with FW35, FW33 and FW70 fifth wheel models

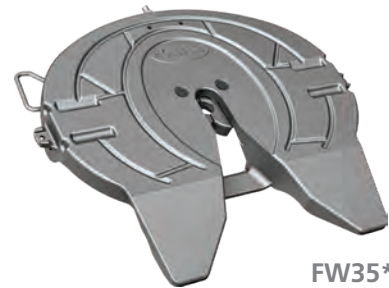

FW35*

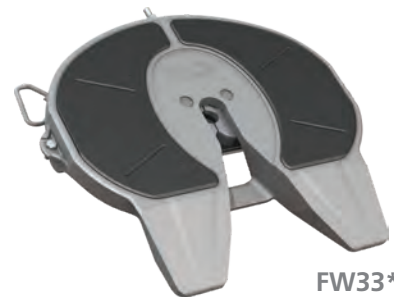

FW33**



FW70*

*Maximum vertical load and drawbar pull capacity is determined by top plate model specified.

**FW33 is approved for Moderate Duty applications only.

NOTE: See the HOLLAND Fifth Wheel Catalog and Specification Guide (XL-FW10066SG) for more information.

INDUSTRY LEADING CAPACITY
200,000 lbs.
Maximum Drawbar Pull*

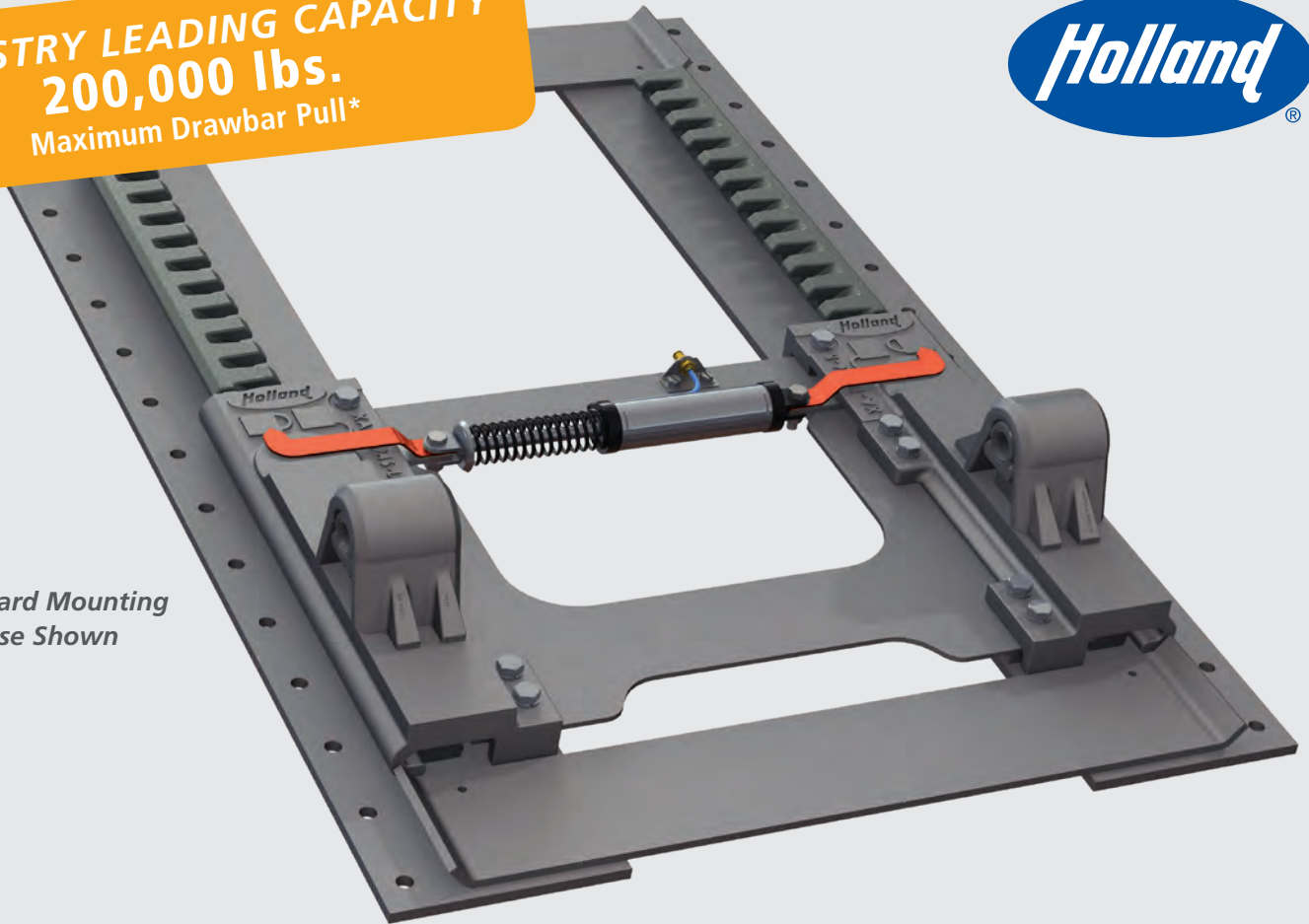

*Outboard Mounting
Base Shown*

INBOARD & OUTBOARD MOUNTING SYSTEMS

– available to meet all OEM and customer mounting needs. Outboard mounting is no longer considered a “special” order.

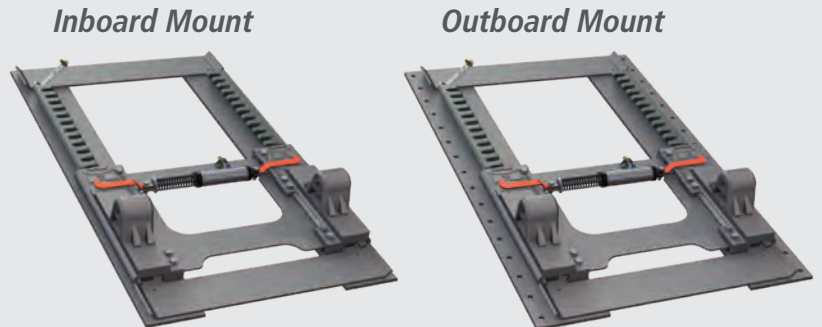

Inboard Mount

Outboard Mount

KOMPENSATOR® MOUNTING SYSTEMS

– provide fifth wheel top plate side-to-side cradle movement on uneven terrain. This relieves torsional stress and twist for rigid trailers.



NO-TILT MOUNTING SYSTEMS

– allow the fifth wheel top plate to convert to a rigid No-Tilt fifth wheel for applications where articulation is provided on the trailer.

Note: Available with FW35 and FW70 top plates only.

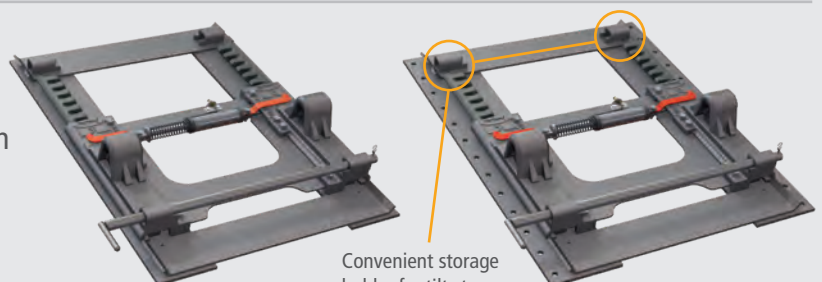

Convenient storage holder for tilt stop bar when not in use.

SAF Holland Group



TRAILER AXLES AND
SUSPENSION SYSTEMS



COUPLING AND
LIFTING SYSTEMS



SUSPENSIONS FOR
TRUCKS AND BUSES



SUSPENSIONS AND
AXLE SYSTEMS



BUS AIR SUSPENSION
SYSTEMS



V. ORLANDI
TOWING
SYSTEMS



TRAILER AXLES/SUSPENSIONS,
COUPLING AND LIFTING
SYSTEMS

safholland.com

SAF-HOLLAND, Inc.

888.396.6501 Fax 800.356.3929

SAF-HOLLAND Canada Limited

519.537.3494 Fax 800.565.7753

Western Canada 604.574.7491 Fax 614.574.0244