

Service Bulletin

FW35 Series Fifth Wheel

Important Seasonal Preventative Maintenance for FW35 Fifth Wheels

July 2019

General Information

The two most important steps in eliminating fifth wheel operating difficulties are:

1. Proper fifth wheel preventative maintenance procedures (including "as needed" lubrication).
2. Proper coupling procedures.

⚠️ WARNING Failure to properly maintain the fifth wheel could result in tractor-trailer separation which, if not avoided, could result in death or serious injury to others.

1. Fifth Wheel Lubrication

Routine periodic maintenance and lubrication are a necessary part of the FW35 fifth wheel's service life. To get the maximum service life, perform steps 1-3 at the intervals listed.

1. Lubricate the locking mechanism every three (3) months or 30,000 miles (**Figure 1**).
2. Thoroughly clean (removing all excessive grease) and adjust the locking mechanism every six (6) months or 60,000 miles. Re-lubricate as indicated in **Figure 1**. (Specific adjustment procedures for the FW35 are available in the "Fifth Wheel Adjustment" section of Document No. XL-FW10009UM-en-US, available on the internet at www.safholland.us.)
3. Inspect for bent, broken or missing parts every six (6) months or 60,000 miles. Replace as necessary (using only SAF-HOLLAND® Original Parts).

If equipped with air release, follow Steps 4-9 for lubrication of the air cylinder.

4. Inspect the air cylinder tube and shaft for dents, bending, or other damage and replace as necessary.

continued

Figure 1

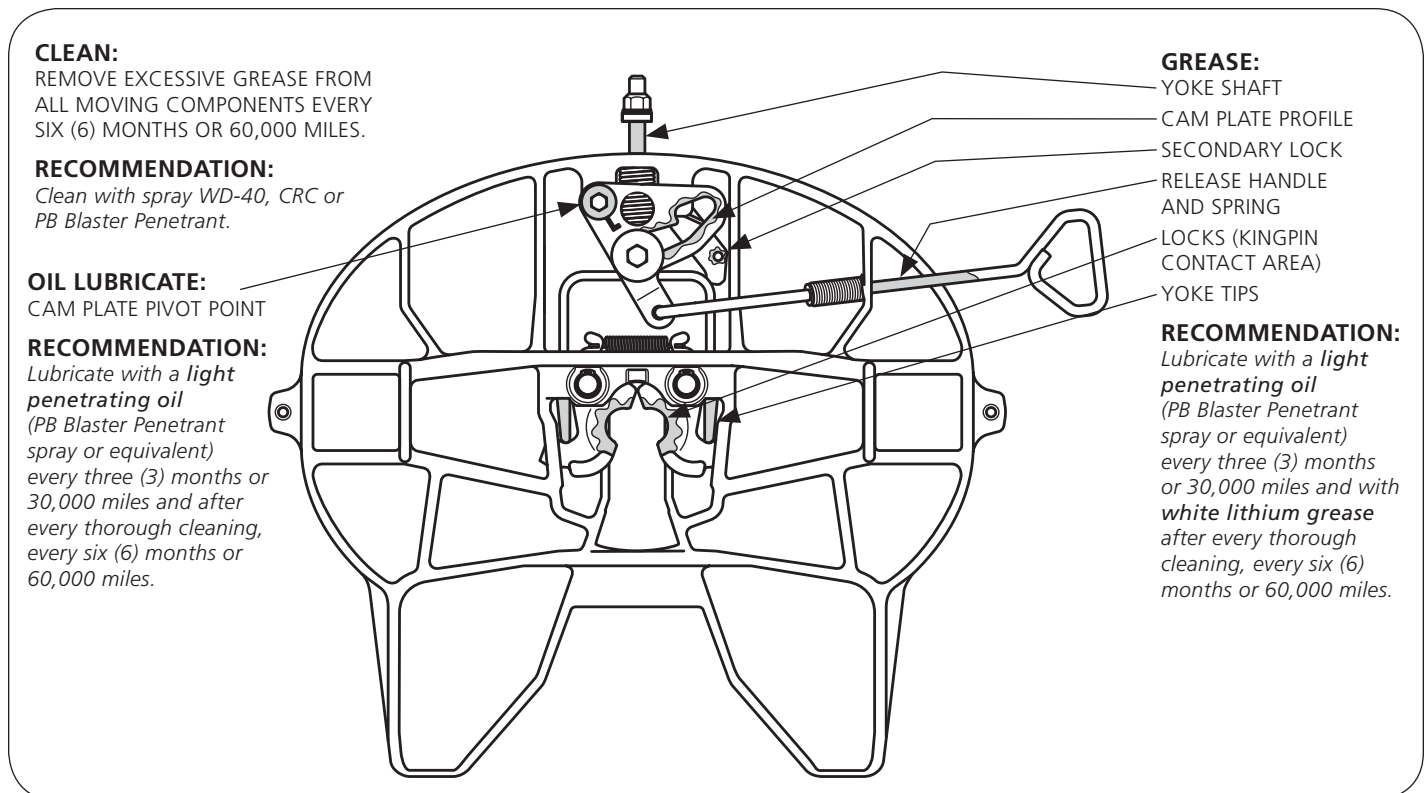

1. Fifth Wheel Lubrication *continued*

5. Activate the air cylinder control to extend the piston and shaft to its full travel length (**Figure 2**).
6. Clean the exposed piston shaft with penetrating oil and a clean shop towel. DO NOT use any abrasives on the exposed shaft as abrasives could damage the piston shaft.
7. De-activate the air cylinder.
8. Remove the supply air line and add two to four (2-4) drops of air tool oil to the cylinder through the supply fitting. Re-install the supply air line (**Figure 2**).
9. Activate and de-activate the air cylinder two to three (2-3) times to work the air tool oil into the cylinder and onto the piston and verify proper operation.

2. Check Operation

Check the operation by locking and unlocking the fifth wheel, using HOLLAND® Lock Tester Part No. TF-TLN-5001. (Refer to Document No. XL-FW10082ST-en-US, available on the internet at www.safholland.us, which contains specific lock tester instructions.) Verify that the fifth wheel is completely closed (**Figure 5**).

3. Coupling Procedures

One of the most common causes of coupling difficulties is improper coupling procedures. A visual inspection is the best way to ensure proper coupling. It is required by law as part of the pre-trip inspection.

Specific coupling instructions for the FW35 are available in the "Coupling Procedures" section of Document No. XL-FW10009UM-en-US, available on the internet at www.safholland.us.

Visually inspect for the following to ensure that the lock is closed:

- a. Nut and washer MUST be snug against the fifth wheel (**Figure 3**).
- b. No gap is permissible between the trailer upper coupler plate and the fifth wheel (**Figure 4**).
- c. Fifth wheel locks MUST be closed around the trailer kingpin with 1/4" (6.35 mm) or less gap visible between the lock jaws (**Figure 5**).

Refer to Document No. XL-FW10009UM-en-US, available on the internet at www.safholland.us, for complete FW35 operating and maintenance procedures. For any other service need, please contact your local HOLLAND representative. (Customer Service phone/fax numbers are listed below.)

Instructional videos are available on the internet at:
youtu.be/dQ8rdoghtYA (FW35 Rebuild/Lock Adjustment Procedures)
youtu.be/zHKjPkXAVb8 (FW35 Coupling Procedures)
youtu.be/LphFphQwFig (FW35 Uncoupling Procedures)

Figure 2

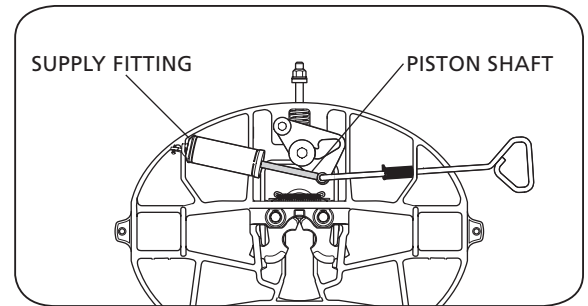

Figure 3

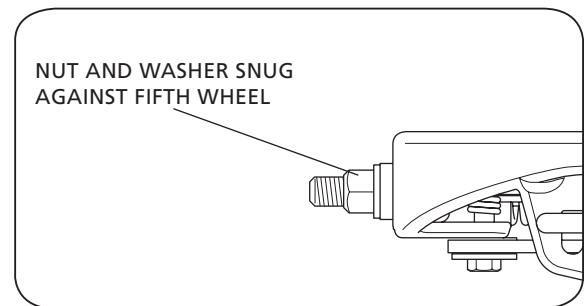

Figure 4

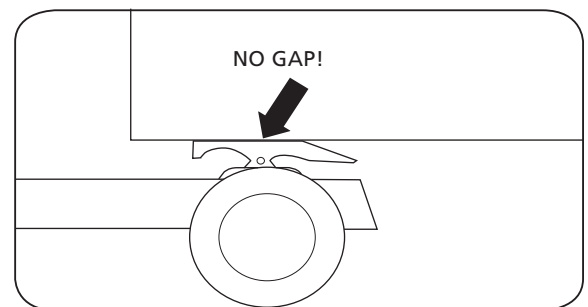

Figure 5

