

Rebuilding Procedures

NoLube[®]

Fifth Wheel Top Plates

- XA-311-A
- XA-311-A-L
- XA-311-A-02
- XA-311-A-02-L

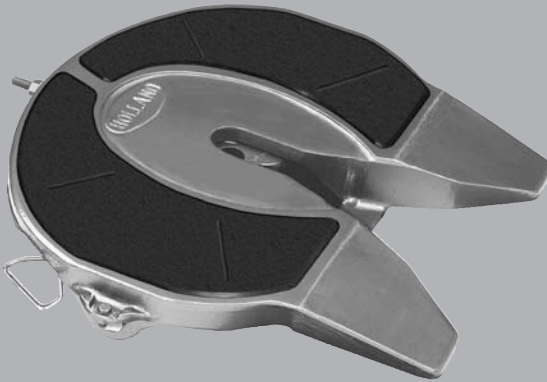

GENERAL SAFETY INFORMATION

Notes, Cautions, and Warnings

You must read and understand all of the safety procedures presented in this manual before starting any work on the SAF-HOLLAND product.

NOTE: In the United States, work shop safety requirements are defined by federal and/or state Occupational Safety and Health Act or equivalent laws in other countries. This manual is written based on the assumption that OSHA or other applicable employee safety regulations are followed by the location where work is performed.

Proper tools must be used to perform the maintenance and repair procedures described in this manual. Many of these procedures require special tools.

Throughout this manual, you will notice the terms “**NOTE**”, “**IMPORTANT**”, “**CAUTION**”, and “**WARNING**” followed by important product information. So that you may better understand the manual, those terms are as follows:

NOTE: Includes additional information to enable accurate and easy performance of procedure.

IMPORTANT: Includes additional information that if not followed could lead to hindered product performance.

CAUTION Used without the safety alert symbol, indicates a potentially hazardous situation which, if not avoided, may result in property damage.

 **CAUTION** Indicates a potentially hazardous situation which, if not avoided, may result in minor or moderate injury.

 **WARNING** Indicates a potentially hazardous situation which, if not avoided, could result in death or serious injury.

Fifth Wheel Design and Intended Use

1. For pulling trailers with standard SAE kingpins which are in good condition and securely mounted or locked in position in the trailer.
2. For on-highway hauling applications.
3. Within the capacities stated in SAF-HOLLAND literature.
4. As recommended in SAF-HOLLAND literature (available from www.safholland.us).

Holland Fifth Wheels are NOT Designed or Intended For

1. Use with non-SAE kingpins, such as kingpins which are bent, improper size or dimensions, not secured to maintain SAE configuration, or which are installed in warped trailer bolster plates.
2. Tow-away operations which damage or interfere with the proper operation of the fifth wheel.
3. The attachment of lifting devices.
4. The transport of loads in excess of rated capacity.
5. Off-highway applications and use.
6. Applications other than recommended.

BEFORE REBUILDING

Review the trouble-shooting hints below. You may find that rebuilding is unnecessary.

The Fifth Wheel is hard to *hook up* to a trailer

CK'D	POSSIBLE CAUSE	REMEDY
<input type="checkbox"/>	Trailer may be too high; the kingpin is not entering the locks properly.	Adjust landing gear so that fifth wheel picks up trailer.
<input type="checkbox"/>	Locks are closed.	Pull release handle.
<input type="checkbox"/>	Accumulated rust or grime interfering lock operation. several times.	Clean well, then spray a light lubricant or with diesel fuel on all moving parts and operate
<input type="checkbox"/>	Bent release handle or kingpin or damaged bolster plate may be interfering with lock movement. edge – repair or replace as required.	Check and replace as necessary. Check the kingpin with a Holland TF-0110 Kingpin Gage and bolster plate with a 48" straight
<input type="checkbox"/>	The locks may be damaged.	Inspect and replace, if required, following the procedures in this manual.
<input type="checkbox"/>	The fifth wheel may need rebuilding.	Follow the procedures contained in this manual using the appropriate rebuilding kit.

The Fifth Wheel is hard to *unhook from* a trailer

CK'D	POSSIBLE CAUSE	REMEDY
<input type="checkbox"/>	The secondary lock is not released.	If manual secondary – pull release handle and lock open by hooking the handle on the top plate. If automatic secondary – inspect for missing or broken parts and repair or replace as required.
<input type="checkbox"/>	The tractor may be putting pressure the locks.	Set trailer brakes. Back the tractor into against the trailer to relieve pressure on fifth wheel locks. Set tractor brakes. Pull the release handle.
<input type="checkbox"/>	Rust or grime on locking mechanism.	Clean well, then spray a light lubricant or diesel fuel on all moving parts, including release handle, and operate several times.
<input type="checkbox"/>	Bent kingpin or damaged bolster plate.	Check the kingpin with a Holland TF-0110 Kingpin Gage and bolster plate with a 48" straight edge – repair or replace as required.
<input type="checkbox"/>	Fifth wheel locks may be tight.	Check lock adjustment following the adjusted too procedures on page 15.
<input type="checkbox"/>	Release handle will not stay out or be held out when unlocking.	Replace the cam and release handle spring. must Follow the procedures in this manual.

IF REBUILDING IS REQUIRED

Please check to make sure you have the right rebuild kit for your fifth wheel top plate.

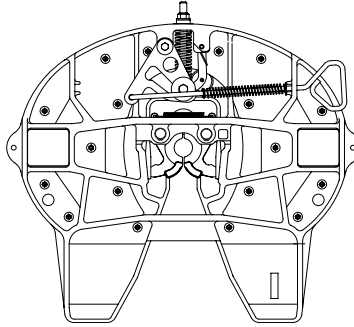

REBUILD KIT NUMBERS FOR LEFT HAND (ROAD SIDE) RELEASE

RK-311-A-L (w/Automatic Secondary Lock)

RK-311-A-02-L (w/Manual Secondary Lock)

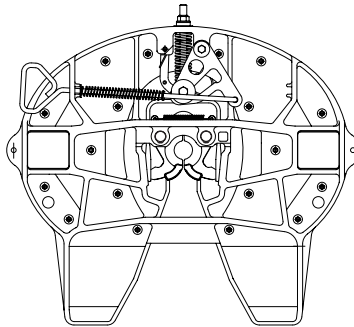

REBUILD KIT NUMBERS FOR RIGHT HAND (CURB SIDE) RELEASE

RK-311-A (w/Automatic Secondary Lock)

RK-311-A-02 (w/Manual Secondary Lock)

REBUILDING PROCEDURES

This manual contains rebuild procedures for the NoLube fifth wheel top plate.

To replace the lube plates and pocket inserts. Please refer to Holland publication XL-FW338 for instructions.

Disassembly and Inspection

1. Remove the fifth wheel top plate from the tractor.
2. Place fifth wheel top plate upside down on a flat working surface.
3. Completely disassemble the fifth wheel top plate.

IMPORTANT: This rebuild procedure will result in several parts of your fifth wheel being replaced. **"NEW"** parts are included in the rebuild kit that came with this procedure. Do not reuse **"OLD"** parts that were removed during disassembly.

4. Thoroughly steam clean the top plate.
5. Inspect the top plate for cracks, damage, distortion and loose lock pin holes.

Fifth wheels with cracks or loose lock pin holes must be replaced.

IMPORTANT: **DO NOT** attempt to repair or rebuild the fifth wheel if the top plate is cracked, damaged or distorted, or if the lock pins do not fit tightly in the top plate.



WARNING Failure to replace a cracked, damaged or distorted top plate could result in improper fifth wheel operation and trailer separation which, if not avoided, could result in serious injury or death.

PARTS BREAKDOWN

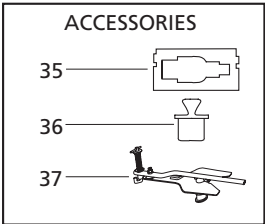
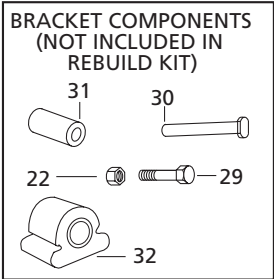
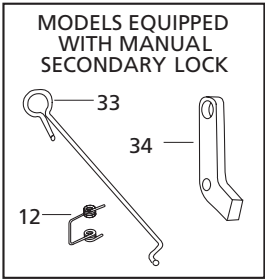
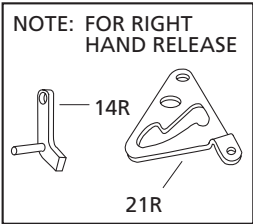
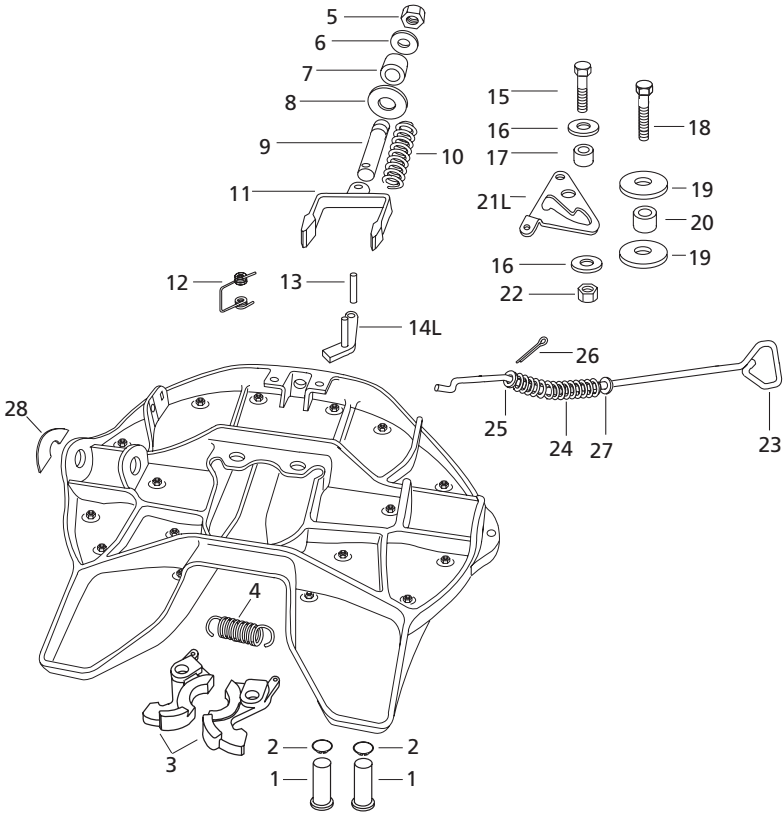

PARTS LIST

ITEM NO.	PART NO.	NO. REQ.	PART NAME
1	XA-10256	2	Lock pin
2	XB-07398	2	Retaining ring
3	XA-10853-SP	1	Lock set
4	XB-07628	1	Extension spring
5	XB-HNH-34-F	1	Locknut (3/4"-16)
6	XB-PW-1316-112	1	Washer (1-1/2" O.D. x 13/16" I.D.)
7	XB-1127	1	Rubber washer
8	XB-02312	1	Lock adjustment tag
9	XA-1706	1	Yoke shaft
10	XB-1505	1	Compression spring
11	XA-10257	1	Yoke
12	XB-2149	1	Torsion spring
13	XB-21-S-500-2750	1	Roll pin (1/2" x 2-3/4')
14L	XA-10261	1	Secondary lock (left-hand)
14R	XA-10451	1	Secondary lock (right-hand)
15	XB-2083	1	Hex head cap screw (1/2"-20 x 1-3/4')
16	XB-10294	2	Washer (2-1/4" O.D. x 17/32" I.D.)
17	XA-10265	1	Pivot roller (1/2" I.D.)
18	XB-CX-58-F-134	1	Hex head cap screw (5/8"-18 x 1-3/4')
19	XB-10259	2	Washer (2-5/8" x 21/32')
20	XA-10343	1	Cam track roller (5/8" I.D.)
21L	XA-10258	1	Cam plate (left-hand)
21R	XA-10450	1	Cam plate (right-hand)
22	XB-T-69-A	1	Locknut (1/2"-20) (2 add'l. req'd. for brackets)
23	XA-10344	1	Release handle (universal for both left and right)
24	XB-07291	1	Compression spring
25	XB-PW-1732-1-116	1	Washer (1-1/16" O.D. x 17/32" I.D.)
26	XB-07508	1	Cotter pin (1/8" x 1-1/4')
27	XB-T-49	1	Washer (1-3/8" O.D. x 9/16" I.D.)
28	XB-07610	1	Operation tag
29*	XB-C-95	2	Hex head cap screw (1/2"-20 x 1-1/4')
30*	XE-06356	2	Bracket pin
31*	XB-1604-5	2	Rubber bushing (brackets mfg'd prior to 5/82)
32*	XB-0011-2	2	Rubber bushing (brackets mfg'd after 5/82)
33**	XA-10459	1	Manual secondary lock release handle
34**	XA-10458	1	Manual secondary lock
35*	TF-0110	1	Kingpin gage
36*	TF-0237	1	2" Lock gage (plug)
37*	TF-TLN-5001	1	Kingpin lock tester

* Parts not included in rebuild kit (available from your local Holland distributor.)

** Parts included in rebuild kits RK-311-A-L-02 and RK-311-A-02

Lock Installation

1. Lubricate the lock pin holes of the lock jaws (*Item 3*) and the areas shown in **FIGURE 1** with Never-Seez (provided in kit). **DO NOT SUBSTITUTE.**

FIGURE 1

Lubricate shaded areas and areas indicated by a thick black line.

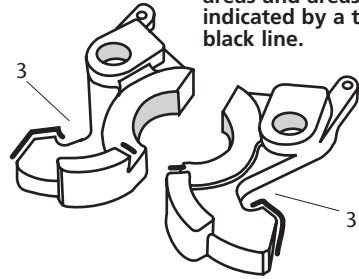

2. Align the lock jaws (*Item 3*) in the casting, as shown.

With fifth wheel upside down, position lock jaws so that kingpin guides are facing up, as shown.

FIGURE 2

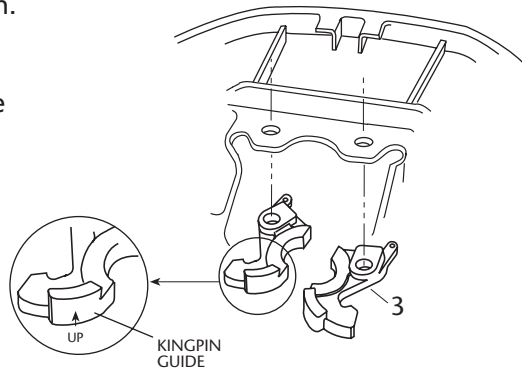

3. Drive lock pins (*Item 1*) into casting until heads are flush with casting.
4. Insert retaining rings (*Item 2*) on to lock pins

FIGURE 3

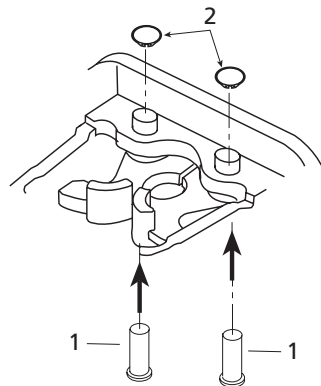

Lock Installation *continued*

5. Position a 2" diameter "plug" into the lock jaws.

A lock gage, Holland part number TF-0237 (*Item 36*) is available at all Holland distributors.

⚠️ WARNING

You must use a Holland lock gage (TF-0237) or a precision plug that is 2.000"± .005" for proper installation of the locking mechanism. Failure to follow the above procedures may cause the fifth wheel to fail or malfunction, which may lead to serious injury or death.

FIGURE 4

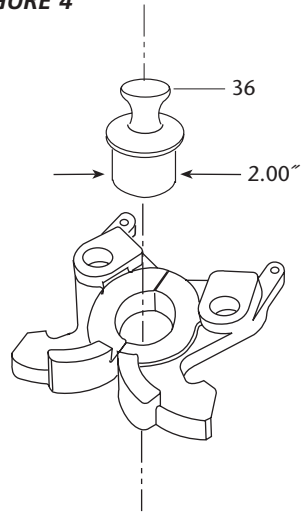

Yoke Installation

1. Lubricate the tips of the yoke (*Item 11*) with Never-Seez, as shown.

FIGURE 5

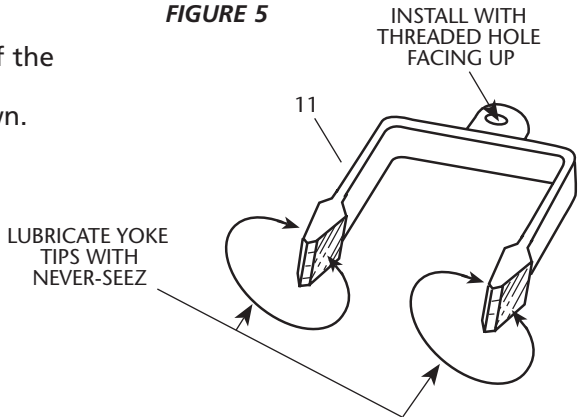

2. With the threaded hole facing up, slide yoke (*Item 11*) into casting. Tap lightly to seat yoke around locks.

FIGURE 6

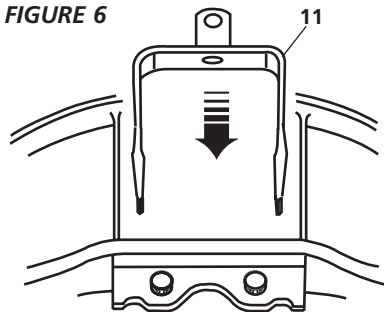

Yoke Installation *continued*

3. Inspect the amount of yoke tip engagement. Yoke tips must extend flush with the end of the locks and no more than 1/2" past the locks.

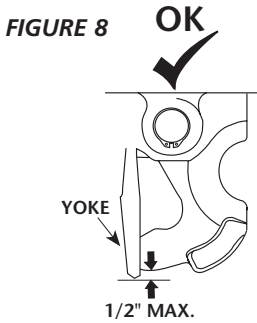
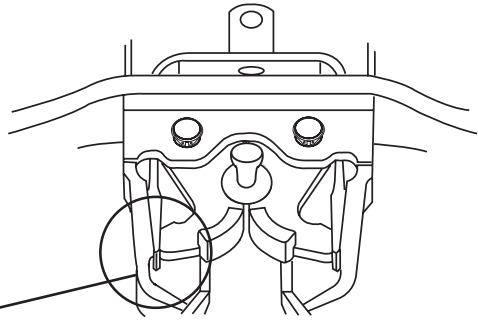

FIGURE 7



If the new yoke extends more than 1/2" past the locks, **DO NOT USE**. Discard it and order Holland part number XA-10257-THK from your nearest Holland distributor.

4. Install lock spring (*Item 4*), as shown.
5. Install yoke spring (*Item 10*) as shown below.
6. Next, slide the yoke shaft (*Item 9*) into the casting, through the spring and into the yoke. Align the recessed hole in the shaft with the threaded hole in the yoke.

In this order, slide tag (*Item 8*), rubber washer (*Item 7*) and 1-1/2" washer (*Item 6*) onto the yoke shaft. Then start lock nut (*Item 5*) finger tight.

FIGURE 9

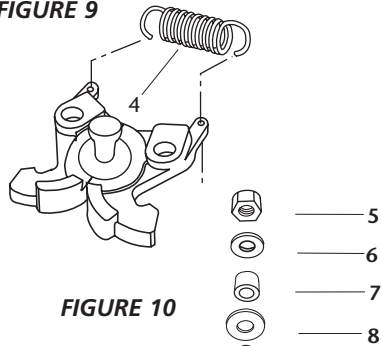
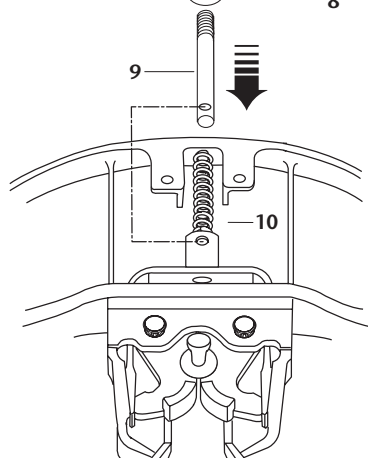

FIGURE 10



Release Handle Installation

1. Slide release handle (*Item 23*) through hole in side of casting, as shown.

LEFT-HAND RELEASE

Use Hole "A"

RIGHT-HAND RELEASE

Use Hole "B"

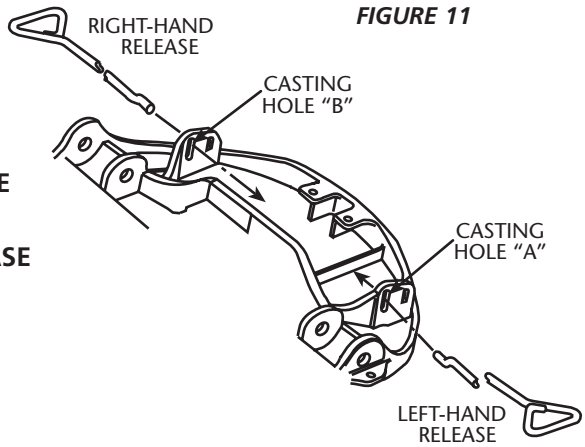

2. In this order, slide the 1-3/8" washer (*Item 27*), handle spring (*Item 24*) and 1-1/16" washer (*Item 25*) over the "S" bend in the release handle.

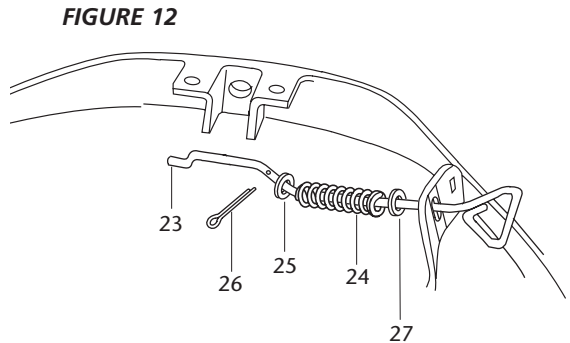

3. Compress the spring using the 1-1/16" washer (*Item 25*) until the cotter pin hole is exposed. Then, insert the cotter pin (*Item 26*) into the hole.
4. Spread the cotter pin and wrap it completely around the release handle.

FIGURE 13

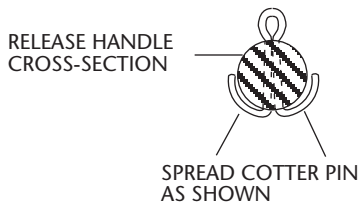

Cam Plate Installation

1. Inspect the cam plate (*Item 21L or Item 21R*) for burrs. Remove as required.
2. Lubricate the cam plate track and pivot hole with light grease.
3. Connect the raised tab in the cam plate to the "S" bend in the release handle, as shown.
4. Position the cam plate attachment hole over the proper casting lug hole, as shown.
5. Slide a 2-1/4" washer (*Item 16*) between the cam plate and casting lug hole with the rounded side of the washer facing the cam plate.
6. Install the 1/2" roller (*Item 17*) into the cam plate and place a second 2-1/4" washer (*Item 16*) on top of the roller with the rounded side facing the cam plate.
7. Install the 1/2" bolt (*Item 15*) through the washers, roller and top plate lug.
8. Secure the bolt with a 1/2" nut (*Item 22*). Tighten securely. Then check for free movement of the cam plate.

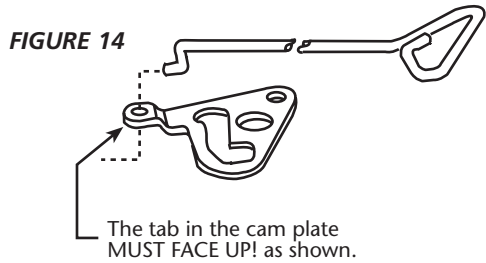

FIGURE 15

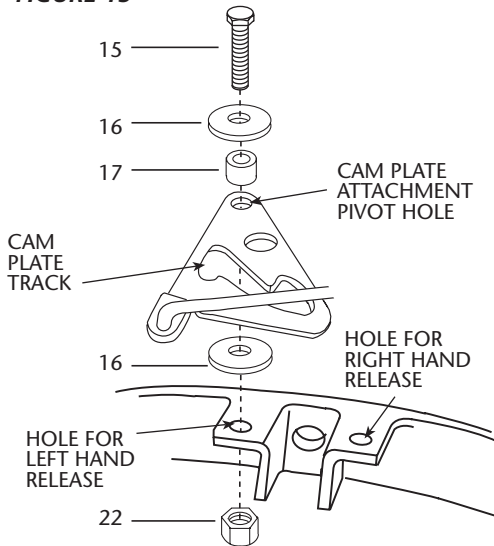
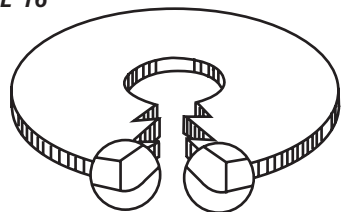

FIGURE 16

NOTE: When installing washers (*Items 16 and 19*), the rounded edge of the washers must always face the cam plate.



Cam Plate Installation *continued*

9. Next, align the cam plate track over the threaded hole in the yoke.
10. Slide a 2-5/8" O.D. washer (*Item 19*) between the yoke and the cam plate with the rounded side of the washer facing the cam plate.
11. Place a 5/8" roller (*Item 20*) into the cam plate track, then place a second 2-5/8" O.D. washer (*Item 19*) over the roller with the rounded side of the washer facing the cam plate.
12. Check the alignment of the recessed hole in the yoke shaft.

FIGURE 17

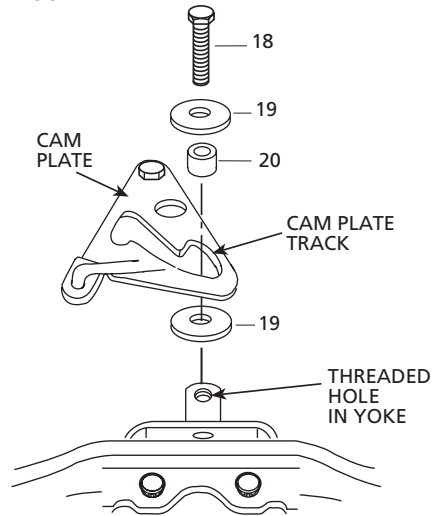

13. Install the 5/8" bolt (*Item 18*) through the washers, roller and cam plate and into the threaded hole in the yoke.
Make sure that the bolt enters the recessed hole in the yoke shaft.
14. Tighten the bolt securely, then check for free movement of the cam plate.

Secondary Lock Installation

Automatic Version

1. Lubricate the hole in the secondary lock with Never-Seez. Start the roll pin (*Item 13*) into the hole in the top plate opposite the cam attachment bolt.
2. Assemble the secondary lock (*Item 14L* or *14R*) to the torsion spring (*Item 12*), as shown.
3. Drive the roll pin (*Item 13*) through the spring and lock until flush with the casting.
4. Check the lock spring for tension and lock for free movement.

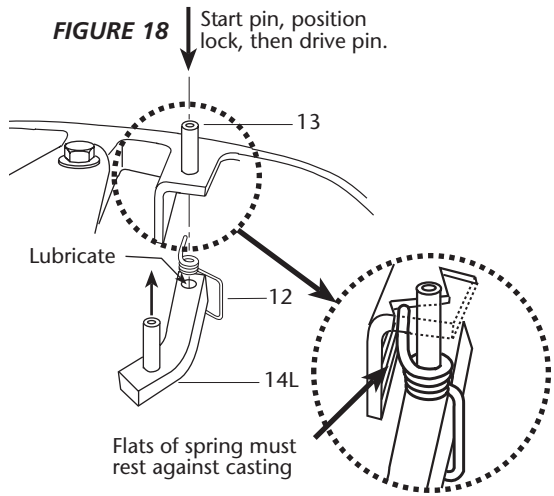

Manual Version

1. Pass the "S" bend of the manual secondary release handle (*Item 33*) through the casting guide hole, as shown below.

For left-hand release, use guide hole "C".

For right-hand release, use guide hole "D".

2. Pass the "S" bend of the release handle through the small hole in the secondary lock (*Item 34*), as shown.
3. Now, attach the secondary lock (*Item 34*) and spring (*Item 12*) to the casting by following Steps 1, 2 and 3 of the "Automatic Version" procedures above.
4. Check for proper spring tension and operation by pulling the release handle and hooking it on the casting, then unhooking the handle and allowing the spring to snap it closed.

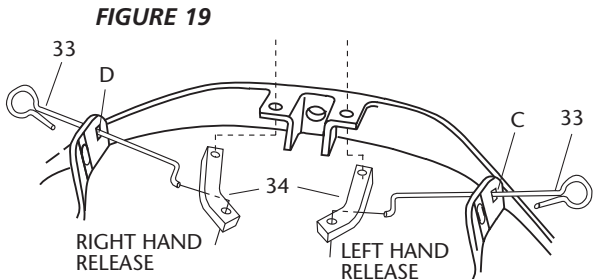

Lock Adjustment

1. If equipped, pull the secondary release handle (*Item 33*) and hook it on the casting. Next, pull the primary release handle (*Item 23*) to open the locks and remove the 2" plug.
2. Turn the fifth wheel right side up and close the locks using a Holland Lock Tester (*Item 37*). See Holland publication XL-FW340 for operating instructions for Holland TF-TLN-5001 kingpin lock tester.
3. Verify that the locks are completely closed around the kingpin, as shown in **FIGURE 21**.

FIGURE 20

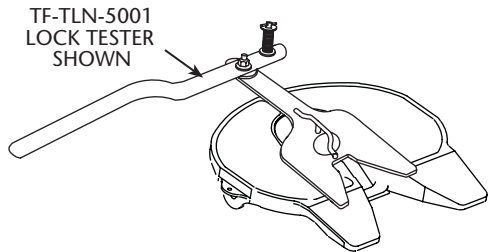
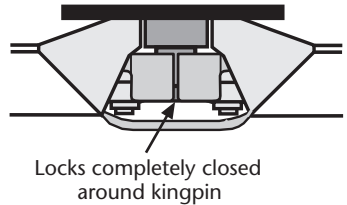
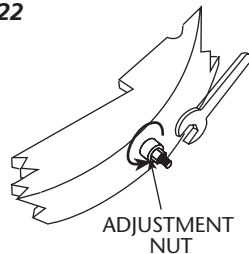

FIGURE 21



4. Now, alternate tightening the adjustment nut and attempting to rotate the lock tester back and forth, as shown. Continue tightening until the lock tester can be rotated but some resistance is felt in the lock tester.

FIGURE 22



The fifth wheel is properly adjusted when there is resistance between the locks and the lock tester, but the lock tester can still be rotated by hand, as shown.

5. Pull the release handle and remove the lock tester.

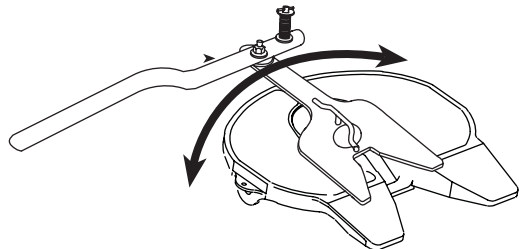

Operation Check

Before you use your fifth wheel, you must verify that it is operating properly.

1. Open and close the fifth wheel at least three (3) times using a Holland Lock Tester.
Each time you close the locks, verify that the locks have closed completely around the kingpin and that the adjustment nut and rubber bushing are seated snug against the casting, as shown.
2. Check for resistance between the locks and lock tester one final time, adjust as needed.

The fifth wheel is now ready for operation.

For additional maintenance procedures, refer to Holland publication XL-FW436, "NoLube Owner's manual."

FIGURE 23

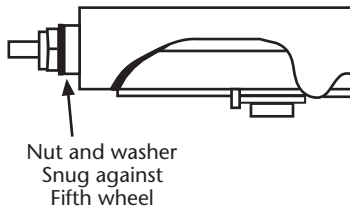
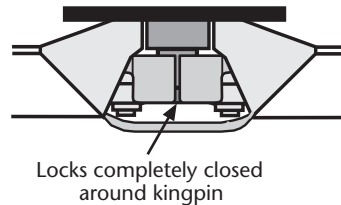

FIGURE 24



⚠ WARNING

If the fifth wheel does not operate properly, **DO NOT USE IT!** Either disassemble and repeat rebuilding procedures or contact your nearest Holland representative for assistance. Using a fifth wheel that does not operate properly could result in malfunction, which may cause death or serious injury.

THIS PAGE INTENTIONALLY LEFT BLANK.

THIS PAGE INTENTIONALLY LEFT BLANK.

THIS PAGE INTENTIONALLY LEFT BLANK.

IMPORTANT: Enclosed is important information for the installation, operation, and maintenance of this product. Read and understand this information.

! WARNING

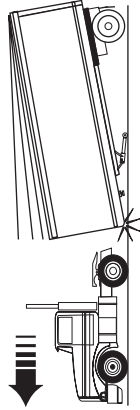

Failure to properly install, operate, or maintain this fifth wheel could result in tractor and trailer separation causing death or serious injury to others.



SAF-HOLLAND USA, Inc.
888.396.6501 Fax 800.356.3929
Western Canada
604.574.7491 Fax 604.574.0244

SAF-HOLLAND Canada Limited
519.537.3494 Fax 800.565.7753