

INSTALLATION INSTRUCTIONS

⚠WARNING Failure to read, understand and follow the important information contained herein may result in a hazardous condition or cause a hazardous condition to develop.

Fifth Wheel Design and Intended Use:

1. For pulling trailers with standard SAE kingpins which are in good condition and securely mounted or locked in position in the trailer.
2. Within the capacities stated in Holland literature.
3. As recommended in Holland literature (available from Holland or Holland distributors).

Holland Fifth Wheels are NOT Designed or Intended For:

1. Use with non-SAE kingpins, such as kingpins which are bent, improper size or dimension, not secured to maintain SAE configuration, or which are installed in warped trailer bolster plates.
2. Tow-away operation.
3. The attachment of lifting devices.
4. The transport of loads in excess of rated capacity.
5. Applications other than recommended.

Installation

General Recommendations

1. Every user and installer using Holland products either recommended or not recommended by Holland, must thoroughly satisfy himself that the installation procedure used is appropriate for the vehicle, product and application.
2. Consult the Holland literature for fifth wheel capacities and applications.
3. Consult the tractor manufacturer's body builder's book and the latest SAE and D.O.T. standards for additional installation methods. Holland recommends the *T.M.C. Recommended Maintenance Practice 603B* for installation procedures.
4. Determine the proper fifth wheel position. See SAE J701a for proper placement, as well as the tractor manufacturer's body builder's book.

Note: *The center of the kingpin locks must always be positioned on or ahead of the truck rear axle.*

5. Use Grade 8, 1/2" minimum diameter bolts and Grade "C" locknuts for mounting.
6. Bolt holes can be 1/32" larger in diameter than the bolt fastener. Bolts must be adequately tightened using charted torque ranges in foot-pounds for the recommended Grade 8, 1/2" diameter bolts. Larger diameter Grade 8 bolts and coated fasteners may be used.
7. The bolts attaching the fifth wheel mounting angles to the truck frame require hardened steel washers under both the bolt and under the locknut, unless flanged head bolts or flanged head locknuts are employed.
8. Whenever a cutout is made on the mounting angle, such as required to bypass suspension components, a 1" minimum radius should be used and bolts should be placed within 1-1/2", but not closer than 1" of the cut, fore and aft.

⚠WARNING Do not use U-bolts in fifth wheel installation.

9. Trailer pick-up ramps are recommended at the rear of the truck-tractor frame.
10. When mounting to aluminum frames, follow the truck manufacturer's recommendations. Holland has available a stationary mounting angle intended for use on aluminum frames; contact Holland or Holland Distributors for availability.
11. Review, in addition, the specific information on the following pages for each type of fifth wheel mounting, as well as "*Inspection and Lubrication Prior to Use*".

Tractor Coupler Mounting (Kingpin or Fifth Wheel) Straight Frame - Without a Body:

In addition to the general installation recommendations listed above, the following specific recommendations should be followed:

1. If a folding kingpin is to be installed, see additional procedures under "Tractor Coupler Mounting (Kingpin or Fifth Wheel) - Non-Straight Frame - With or Without a Body," on the next page.
2. Attach the mounting plate (kingpin or fifth wheel plate) to the frame using a full-length mounting angle, ASTM A36, 3" x 3" x 5/16" minimum on each side.
3. When initially positioning the coupler plate for frame holes, the full length of the mounting plate should seat flush on the top and side surface of the truck-trailer frame rails to prevent flexing and give uniform weight

distribution. There should not be a gap over the top of the truck frame rails. It is also recommended to chamfer or smooth sharp edges and corners of mounting materials whenever contact is made with the truck-tractor frame. See *Figure 1* for mounting diagrams. A minimum of four (4) Grade 8, 1/2" diameter (minimum) bolts must be used to attach each mounting angle to the frame. The distance between the bolts must not exceed 8", except when cutouts are required in the mounting angles.

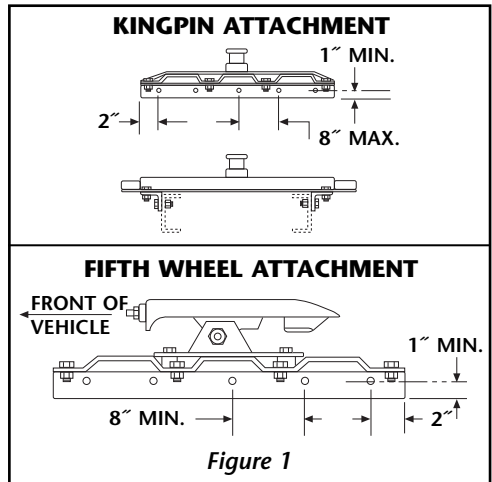

INSTALLATION INSTRUCTIONS *continued*

Tractor Coupler Mounting (Kingpin or Fifth Wheel) Non-Straight Frame – With or Without a Body:

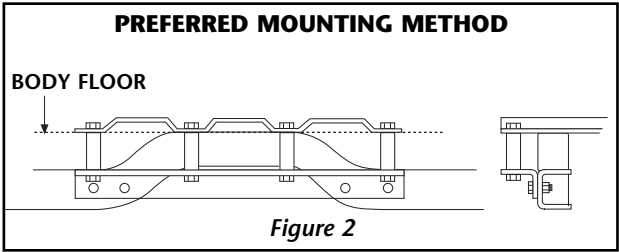

1. Full Angle Mounting – Preferred

In addition to the general installation recommendations listed on the previous page, the following specific recommendations must be followed:

- A. If a folding kingpin is to be installed, the following procedures must be completed before going to step C:
 1. The 40" dimension of the kingpin plate must be installed parallel with the rear axle with the upright kingpin centered between the pickup sides.
 2. Check under the floor in the area where the kingpin is to be located to avoid interference with the differential, drive shaft or frame cross members. The area should be clear 3" below the floor when the springs are fully bottomed.
 3. Cut a hole in the truck floor to receive the folding kingpin box (see *Figure 4*).

NOTE: The folding kingpin base is offset. Cut three sides of the floor and fold the flap down and out of the way.

- B. Initially position the coupler plate in the box or on the frame in the desired position (at least 2" ahead of the rear axle). If possible, the coupler plate should be attached using a full-length mounting angle (3" x 3" x 5/16" minimum, ASTM A-36) on each side (see *Figure 2*).

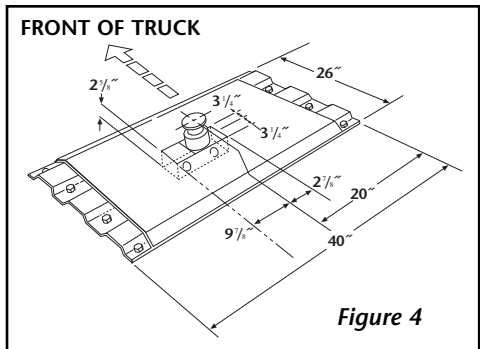

- C. A minimum of four (4) Grade 8, 1/2" diameter (minimum) bolts must be applied to attach each mounting angle to the frame rail.
- D. Proper length tube spacers (3/4" I.D. x 1 1/2" O.D. recommended) must be used to shim the distance between the mounting angle and the coupler mounting plate (minimum of 4 per side).

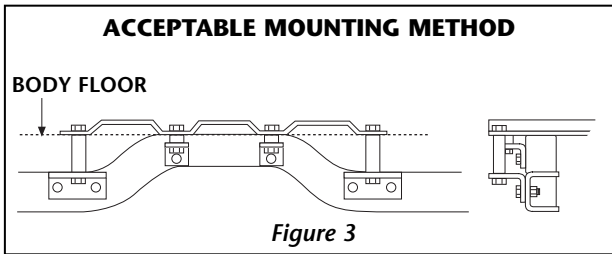

2. Tab Mount - Acceptable

In addition to the general installation recommendations listed on the previous page, the following specific recommendations must be followed:

- A. If a full-length mounting angle is impractical, an angle TAB mount, as shown in *Figure 3*, is acceptable. The angle TABS should be 3" x 3" x 3/8" x 3" long minimum, using an ASTM A36 steel. A minimum of 4 TABS per side are required.
- B. The TABS must be attached to the tractor frame using 1/2" diameter (minimum) Grade 8 fasteners.
- C. Proper length tube spacers (3/4" I.D. x 1 1/2" O.D. recommended) must be used to shim the distance between the TAB angles and the coupler mounting plate.

Tractor Coupler Mounting – Kingpin or Fifth Wheel Mount:

The kingpin mounting box is designed to be attached to the trailer frame by welding. It is imperative, therefore, that the attachment is substantial enough to develop the full strength of the hitch.

⚠ WARNING When welding, use a procedure which assures a sound, good quality weld and which protects the operator and others. Over-welding may cause distortion and damage and underwelding may not develop sufficient strength. A low hydrogen process and AWS E70XX filler metal are recommended. Take precautions to insure that the trailer electrical system is not damaged by the welding.

1. Weld as shown in *Figure 5*, making 1/4" fillet welds on the inside and 3/16" fillet welds on the outside, with skip welds 2" long on approximately 6" centers (weld 2", skip 4"). Weld inside opposite skips on the outside.
2. Install and adjust inner box to required height. Use the six (6) Grade 5 fasteners provided (2 each hole series) and tighten to 65 ft. - lbs.
3. When installing a fifth wheel on a trailer mounting box, be certain that the open end of the fifth wheel faces the front of the trailer (see *Figure 7A*).

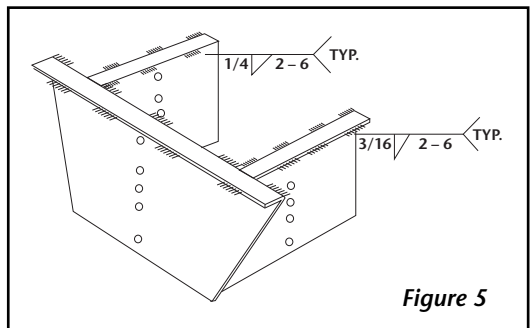

Figure 5

OPERATING INSTRUCTIONS

⚠WARNING Relative to tractor/trailer operations, there are other checks, inspections, and procedures not listed here, which are necessary, prudent, and/or required by law. The following is in addition to these, and pertains to the fifth wheel only. Perform these procedures with the area clear of obstacles and other personnel.

Coupling Procedures

1. Check out the equipment before coupling.
 - A. Make sure that the fifth wheel is properly lubricated, that the locks are open, and that the ramps are tilted in the proper position.
 - B. Make sure the mounting of the fifth wheel is in good condition and is tight.
 - C. Make sure the power/brake line and breakaway line (if the trailer is equipped with electric brakes) and clear of the coupling area.
2. If the tractor is equipped with a body, lower the tailgate.
3. Back up close to the trailer, centering the kingpin on the crotch of the fifth wheel.
STOP!
4. Chock the trailer wheels.
5. Check the trailer height for coupling. The fifth wheel should just touch the kingpin plate; adjust the landing gears as necessary.
6. Back **slowly** under the trailer, keeping the kingpin centered in the crotch of the fifth wheel until the fifth wheel locks firmly on the kingpin. Pull forward to check the completeness of the coupling as an initial check.
7. Visually check to see that the kingpin is in the fifth wheel lock.
8. **Visually check** that the locks are properly locked on the kingpin by the following (3) checks.

CHECK 1

The adjustment nut must be seated against the fifth wheel (see *Figure 6A*).

CHECK 2

The secondary lock must be behind the yoke (see *Figure 6A*).

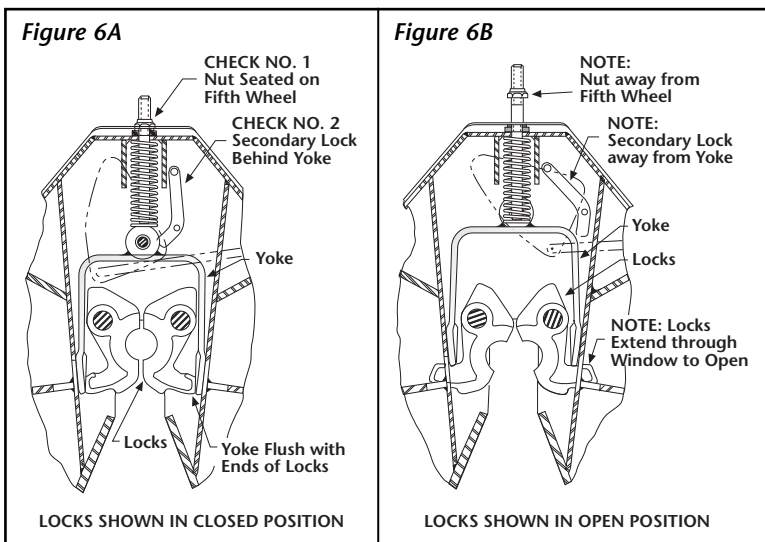

Coupling Procedures *continued*

CHECK 3

The fifth wheel must be flush with the kingpin plate (see *Figure 7A*).

⚠ WARNING A direct visual inspection is required to assure proper coupling. Do not use any fifth wheel which does not operate properly.

9. Connect the power/brake line(s).
10. If the trailer is equipped with electric brakes, connect the breakaway switch line.
11. Retract the landing gears, raise the tailgate, pick up the wheel chocks.

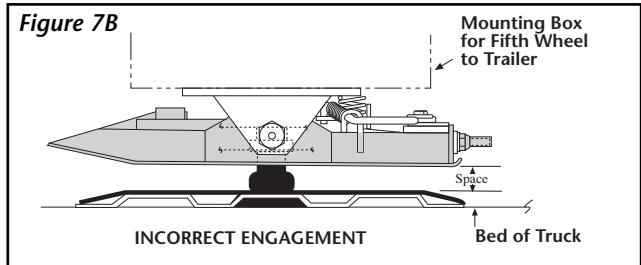
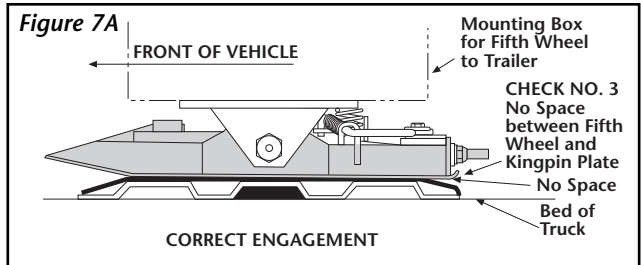

Uncoupling Procedure

1. Set trailer brakes and chock trailer wheels.
2. Lower the landing gear; when the foot pad contacts the ground, crank two or three additional turns to reduce the vertical load on the fifth wheel. Do not raise the fifth wheel off the kingpin plate.
3. If the truck/tractor is equipped with a body, lower the tailgate.
4. Disconnect the power/brake line and, if the trailer is equipped with electric brakes, unhook the breakaway switch line. Do not disconnect at the switch.
5. Open the fifth wheel locks by . . .
 - A. pulling the release handle or . . .
 - B. from the driver's side, slide a pipe release handle over the solid stud, located next to the adjusting bolt and push toward the rear of the vehicle (see *Figure 8*). Remove and store the handle.
6. Drive away from the trailer slowly.
7. Raise the tailgate if so equipped.

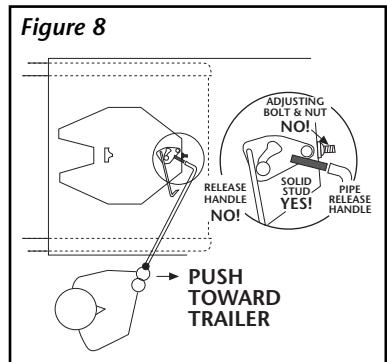

MAINTENANCE PROCEDURES

⚠️WARNING

1. All maintenance must be performed by a qualified person using proper tools and safe procedures.
2. All maintenance must be performed while the tractor is uncoupled from the trailer.

As-Needed Lubrication

1. Keep a water-resistant lithium-base grease applied to the trailer contact surface of the fifth wheel plate.
2. Lubricate all moving parts with a light, rust-resistant oil.
3. Apply a light grease through the grease zerks at the pivot points and the cam.

Periodic Inspections and Adjustments

NOTE: All of the following must be performed every 30,000 miles or 3 months, whichever comes first. Perform the inspections after steam cleaning to assure a good inspection.

Inspection — General

1. Inspect the fifth wheel and the kingpin mountings. Check torque and replace any missing or damaged bolts. Check for broken or distorted components and repair or replace as needed.
2. Inspect the fifth wheel assembly for bent, worn or broken parts. Replace with HOLLAND parts only.

Fifth Wheel Locking Mechanism Inspection and Adjustment

1. Check the operation of the fifth wheel locking mechanism using a HOLLAND TF-TLN-1000 (2" kingpin) or TF-TLN-1500 (31/2" kingpin) Lock Tester. Inspect for proper locking as described in the "Operating Instructions" in this manual.

⚠️WARNING

Do not use any fifth wheel which does not operate properly.

2. Check adjustment of the fifth wheel locks and adjust as required. The lock adjusting nut is located at the front edge of the fifth wheel (see Figure 6A on page X). With the wheel locked around the lock tester, tighten or loosen the nut until the rubber washer seats snugly against the fifth wheel (but can still be turned by hand). Viewed from the adjusting nut, a counter-clockwise rotation of the nut will allow the yoke (see Figure 6A) to move in and tighten the locks on the kingpin. A clockwise rotation will pull the yoke out and loosen the locks. Remove and reinsert the lock tester to verify proper adjustment and coupling.
3. Relubricate by applying a light, rust-resistant oil to all moving parts.



COMMERCIAL PRODUCTS WARRANTY

Holland warrants all Commercial Products (products other than those normally used for personal, family, or household purposes) manufactured by it, when properly installed, to be free from defects in material and workmanship under normal use and service for a period of two (2) years from the date of manufacture, with the exception of elevating fifth wheels for which the warranty period is 180 days.

This warranty is void with respect to any product which has been altered in any way from its manufactured condition, such as intentional modification, accident, corrosion, misuse, failure to provide necessary and reasonable maintenance and is exclusive of normal wear.

The sole responsibility of Holland under this warranty is limited to repairing or replacing at the factory any part or parts which are returned, with transportation charges prepaid, and are found to be defective to the satisfaction of Holland. Written authorization from Holland must be obtained prior to returning any part or parts. No charges for transportation or for labor performed on Holland products by unauthorized persons will be allowed under this warranty.

Holland shall not be liable, in any event, for proximate, incidental, consequential or other damages, including but not limited to damages for loss of production or injury to persons or property arising out of any breach of this warranty.

THERE ARE NO WARRANTIES, EXPRESS OR IMPLIED, INCLUDING THE WARRANTY OF MERCHANTABILITY OR A WARRANTY OF FITNESS FOR A PARTICULAR PURPOSE EXTENDING BEYOND THAT SET FORTH ABOVE.

Warranty

IMPORTANT: Enclosed is important information for the installation, operation, and maintenance of this product. Read and understand this information.

WARNING

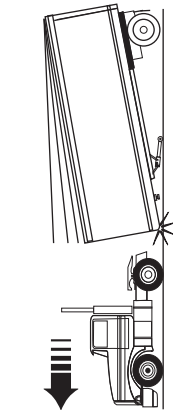

Failure to properly install, operate, or maintain this fifth wheel could result in tractor and trailer separation causing death or serious injury to others.



GO THE DISTANCE.

Copyright © July 2005 • The Holland Group, Inc.