

Electronic Lock Indicator Installation Instructions

RK-10855-L & RK-10855-R
2-Sensor Retrofit Kit for
XA-311, XA-351 and XA-331 Series
Fifth Wheel Top Plates

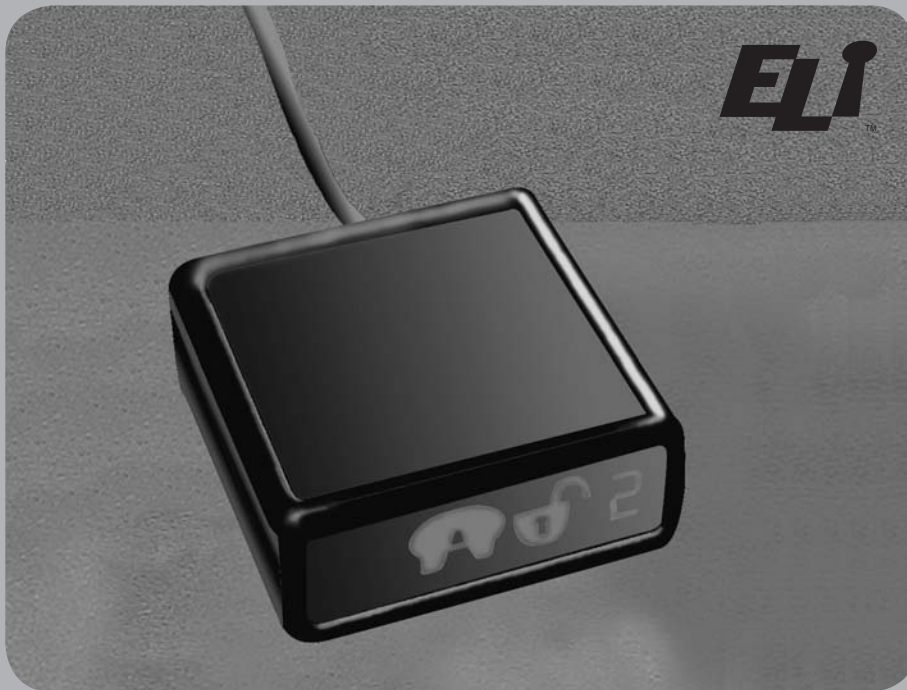

SAFETY INFORMATION

This manual contains retrofit procedures for installing an Electronic Lock Indicator (ELI) on the 3500 fifth wheel top plate (XA-351 Series), and for the 3500 low lube fifth wheel top plate (XA-331 Series) manufactured after January 1, 1997. Use the figures to the right to identify your Holland 3500 Series fifth wheel.

The ELI is NOT available for FW3500 fifth wheel top plates manufactured before December 31, 1996. See figures at right.

IMPORTANT: The electronic lock indicator is a tractor/trailer fifth wheel coupling aid and is intended as an additional safety check to assure the driver of a safe and complete coupling. It does not eliminate the requirement for a visual inspection of the fifth wheel.

⚠️ WARNING ALWAYS GET OUT OF THE TRACTOR CAB AND VISUALLY INSPECT THE FIFTH WHEEL COUPLING! Failure to verify a proper couple can result in tractor and trailer separation, causing death or serious injury to you or others.

IMPORTANT SAFETY INFORMATION

Before attempting ELI retrofit installation, you must read and understand the following:

- **DO NOT** attempt to install ELI on any XA-351 or XA-331 fifth wheel without following the instructions contained in this manual.
- **DO NOT** modify, change, weld, or add to the product. Use only genuine Holland parts. Use only the components supplied in the kit.
- Perform all procedures in a lighted area clear of obstacles and other personnel.
- Always wear safety goggles during removal, installation, or service procedures.
- **DO NOT** strike any part of the product with a steel hammer, except where instructed to do so.
- Observe standard precautions when lifting.

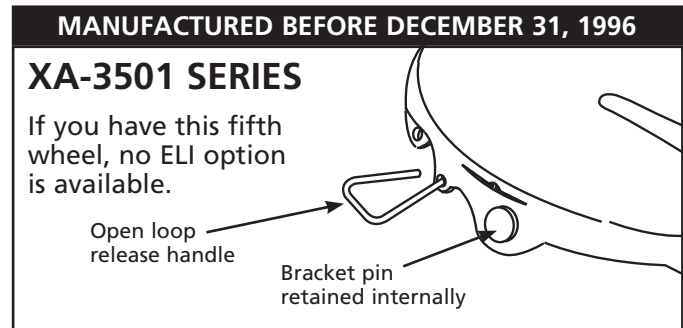
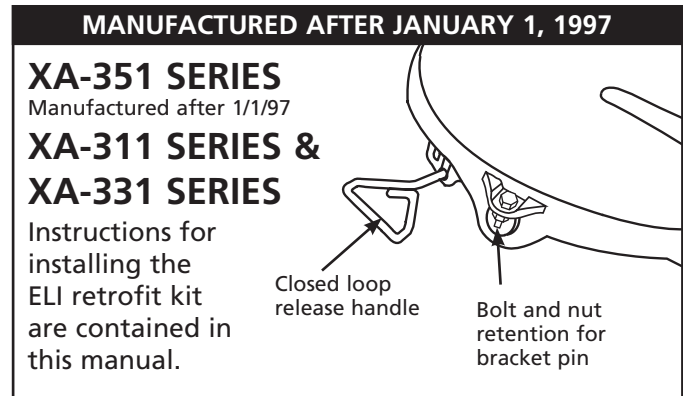

U.S. PATENT #5861802, D442971, 6285278, and other patents pending.

PARTS BREAKDOWN

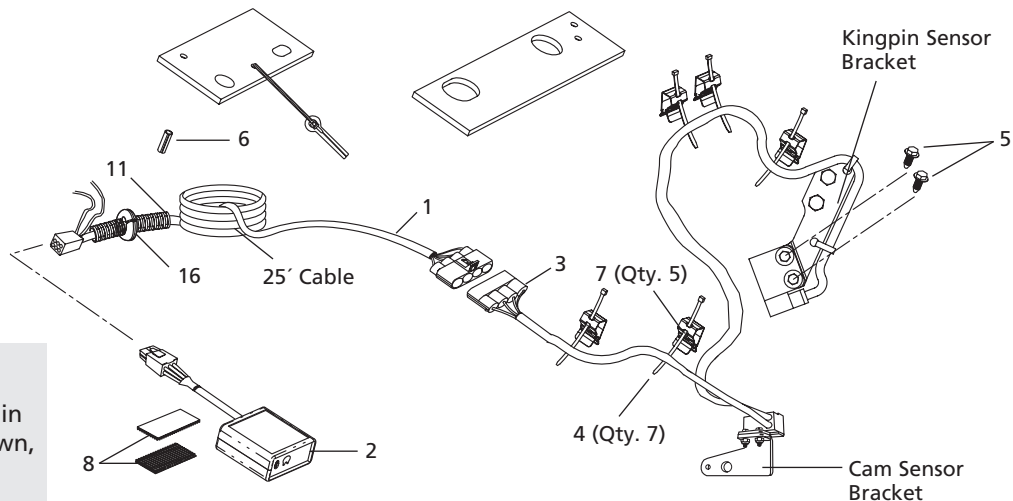

NOTE

The item numbers in this parts breakdown, and in the chart below, correspond to the item numbers referenced throughout this manual.

REQUIRED TOOLS AND SUPPLIES

- Electric drill
- Torque Wrench (ft.-lbs.)
- 3/8" Wrench
- 3/4" Wrench (2)
- 13/16" dia. hole cutter
- Isopropyl alcohol
- Clamps
- Scissors/knife
- Hammer or mallet

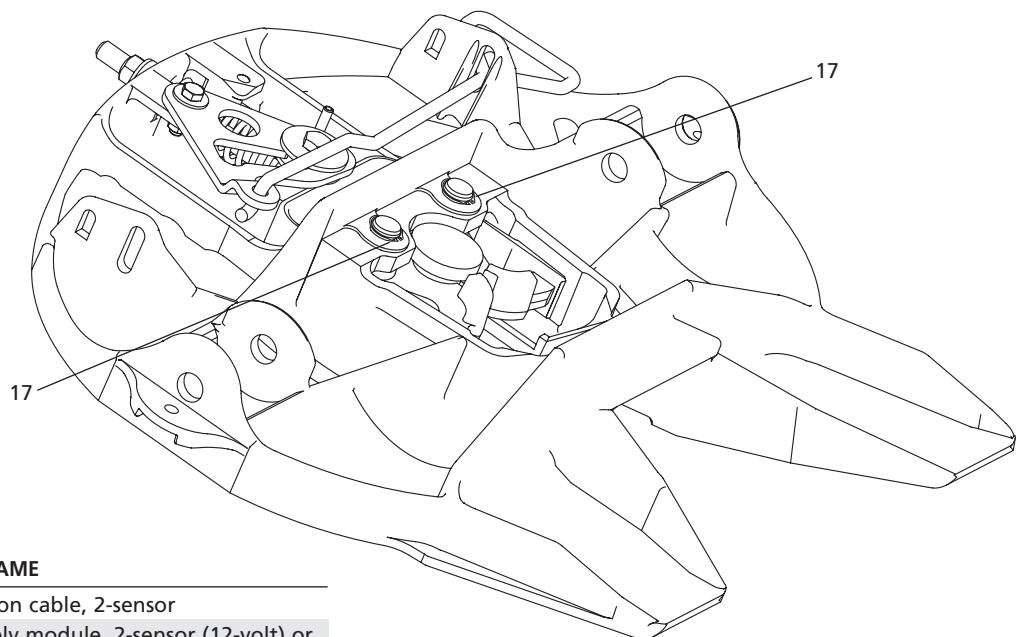

ITEM	PART NO.	NO.	PART NAME
1	XB-10754	1	Extension cable, 2-sensor
2	XB-10758-12	1	Assembly module, 2-sensor (12-volt) or
	XB-10758-24	1	Assembly module, 2-sensor (24-volt)
3	XA-10776-L	1	Harness subassembly, 2-sensor, LH
	XA-10776-R	1	Harness subassembly, 2-sensor, RH
4	XB-01961	7	Cable tie, nylon
5	XB-10074	2	Screw, 1/4"-20 type F, thread cutting
6	XB-21-S-5M-22M	2	Roll pin, 5mm dia. x 22mm large
7	XB-09976	5	Spring clip
8	XB-09782	2	Fastener, reclosable
9	XA-10067	1	Drill fixture, ELI kingpin
10	XA-10055	1	Drill fixture, ELI lock
11		1	Loom, corrugated (part of 1, XB-10754)
12*	XB-08559	2	Washer (1-3/4" O.D. x 9/16" I.D.)
13*	XA-1029	1	Roller (1/2" I.D.)
14**	XB-10068	1	Hex head cap screw (1/2" x 2")
15**	XB-T-69-A	1	Locknut (1/2"- 20)
16	XB-10086	1	Grommet
17	XB-07398	2	Retaining ring
18**	XB-10083	1	Drill bit, #1 split point
19**	XB-10084	1	Drill bit, #7 split point
20**	XB-PW-1732-1-1161	1	Washer (1-1/16" O.D. x 17/32" I.D.)

* Not included in this kit. Items are listed only for reference.

** Included in this kit, but not shown in this drawing.

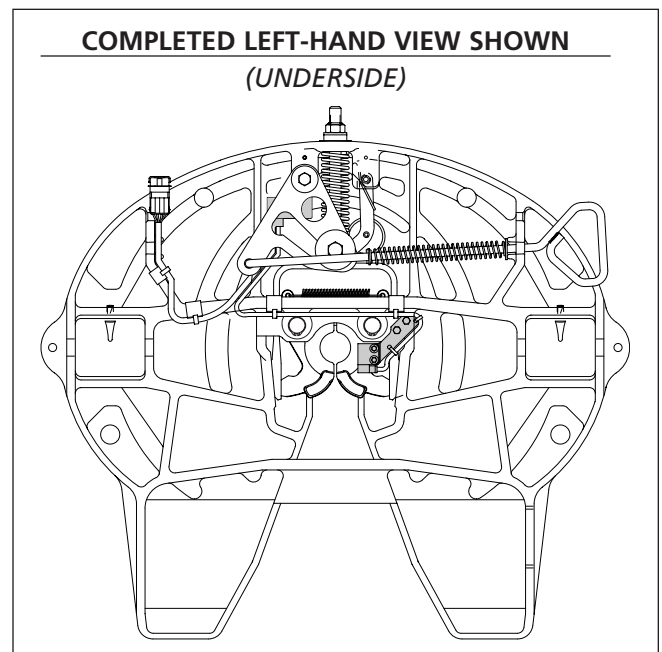

INSTALLATION INSTRUCTIONS

Fifth Wheel Top Plate Preparation

1. Remove the fifth wheel top plate from the tractor.
2. Place top plate upside down on a flat working surface.
3. Remove retaining rings (**ITEM 17**) from lock pins and discard. (See **FIGURE 1**).

FIGURE 1

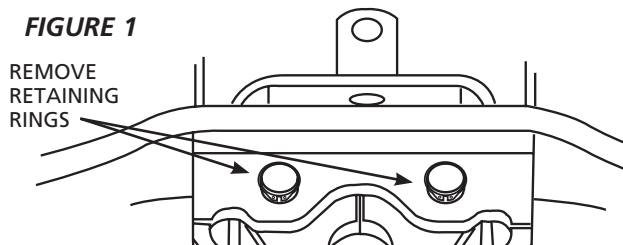

4. Place drill fixture (**ITEM 9**) over lock pins (**FIGURE 2**) with "UP" mark facing up. Clamp the fixture to the fifth wheel.

FIGURE 2

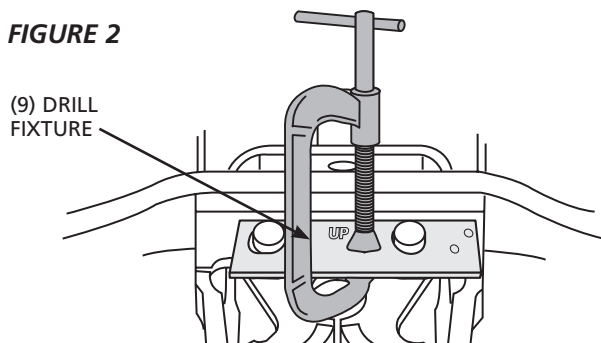

5. Drill both holes 1/2" deep with a #1 (.228) drill bit (**ITEM 18**). Remove and discard the fixture. **Do not** reuse the drill fixture.

FIGURE 3

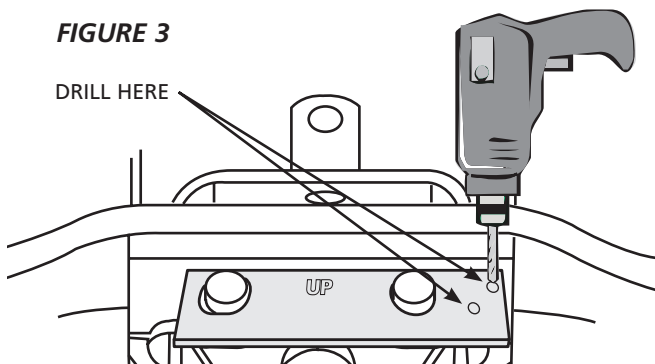

NOTE: Before proceeding, make sure the top plate and work areas are free of chips and burrs.

6. Install the new retaining rings (**ITEM 17**).

FIGURE 4

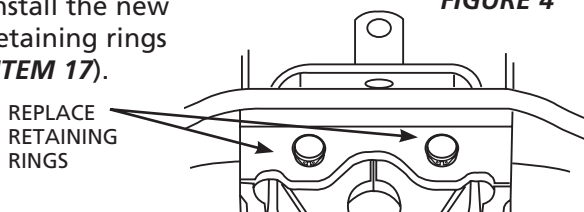

7. Determine whether your top plate has a right- or left-hand release and follow the appropriate instructions.

Left-Hand Release

For Right-Hand Release, go to page 6.

1. Remove the cam bolt and rotate the cam away from lug A.

FIGURE 5

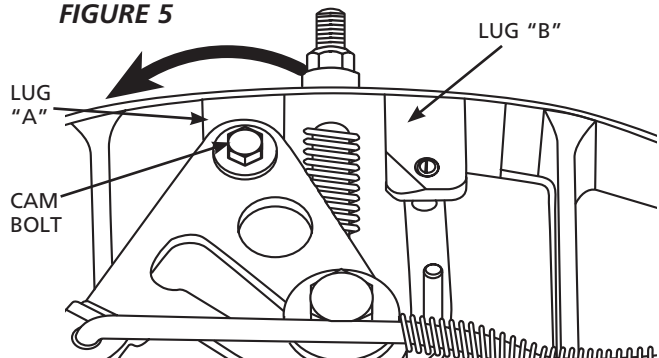

2. Place drill fixture (**ITEM 10**) on top of the lugs with the "L" facing up. Place the cam bolt into the fixture. Insert the locator pin into the hole in LUG "B".

FIGURE 6

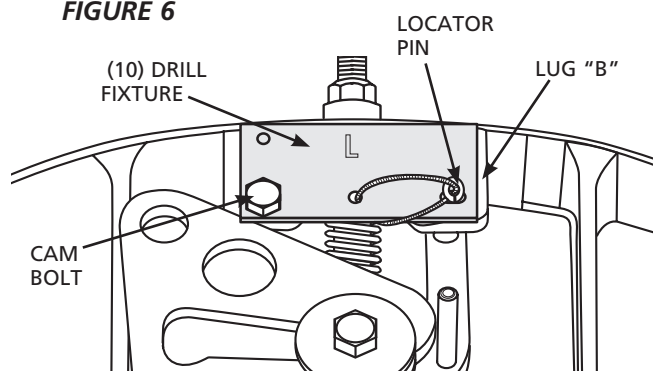

3. Clamp drill fixture (**ITEM 10**) to the fifth wheel. Drill through lug "A" with a #7 (0.201) drill bit (**ITEM 19**). Remove and discard the drill fixture. **Do not** reuse the fixture.

FIGURE 7

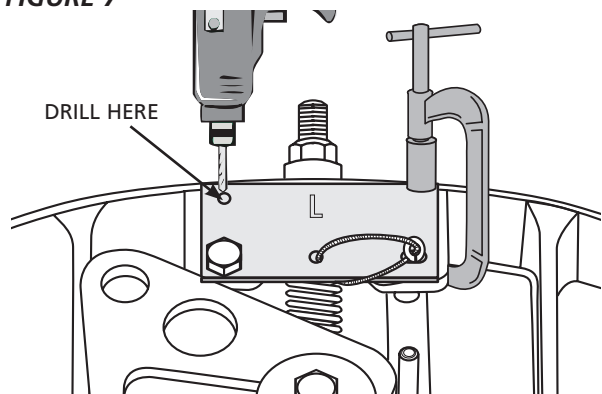

INSTALLATION INSTRUCTIONS

Left-Hand Release *continued*

4. Pound the roll pin (**ITEM 6**) into the newly drilled hole flush with the top of the lug.

FIGURE 8

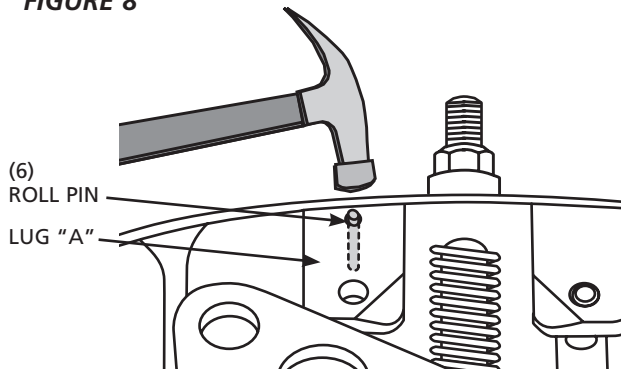

NOTE: Before installing the sensors and harness, make sure the top plate and work areas are free of chips and burrs.

Harness Installation Left-Hand Release

Cam Sensor Bracket Installation

1. Clean and lubricate the cam plate. Install cam sensor bracket under **LUG "A"**. Position **HOLE "B"** onto the bottom of the roll pin (**ITEM 6**).

FIGURE 9

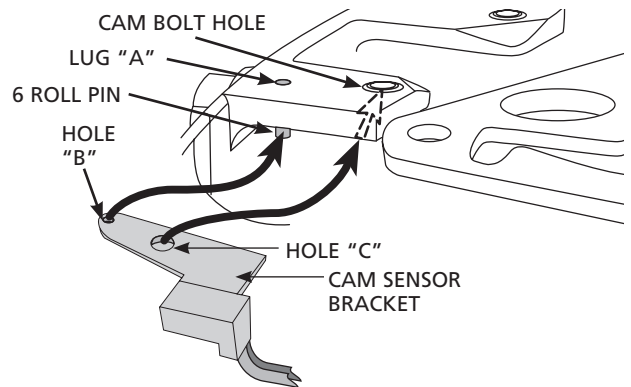

2. Once the cam sensor bracket is attached to the roll pin, line up **HOLE "C"** (see **FIGURE 9**) with the cam bolt hole. Replace the washer (**ITEM 12**) over the cam bolt hole, and rotate the cam plate back into position (see **FIGURE 10**). Re-install the roller (**ITEM 13**) and second washer (**ITEM 12**). Finally, guide the hex head cap screw (**ITEM 14**) through the washer, roller, cam plate, washer, lug, and the cam sensor bracket, add washer (**ITEM 20**). Screw the new locknut (**ITEM 15**) onto the hex head cap screw and tighten securely. Check the cam operation for free movement. Clean away excess grease.

FIGURE 10

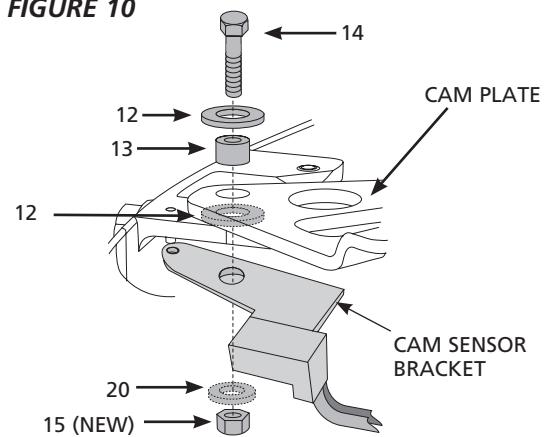

NOTE: When installing the washers (**ITEM 12**), the rounded edge of the washers must always face the cam plate.

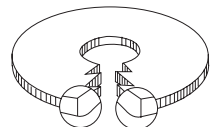

Proceed to "Kingpin Sensor Bracket Installation" on page 7.

INSTALLATION INSTRUCTIONS

Right-Hand Release

1. Remove the cam bolt and rotate the cam away from lug B.

FIGURE 11

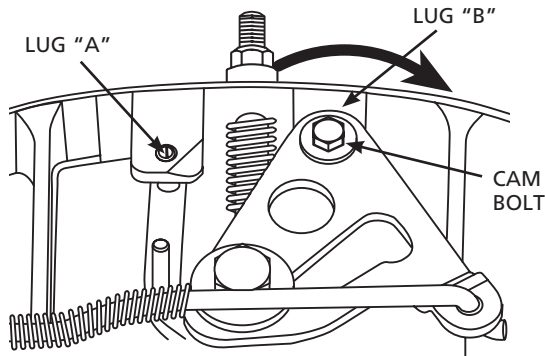

2. Place drill fixture (ITEM 10) on top of the lugs with the "R" facing up. Put cam bolt into the fixture. Insert locator pin into the hole in LUG "A".

FIGURE 12

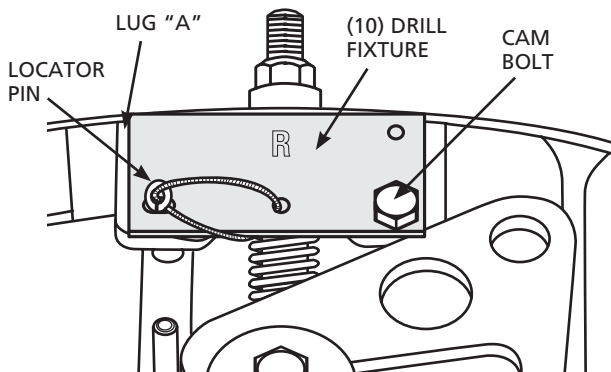

3. Clamp the drill fixture to the fifth wheel. Drill through lug "B" with a #7 (0.201) drill bit (ITEM 19). Remove the fixture after drilling. Do not reuse the drill fixture.

FIGURE 13

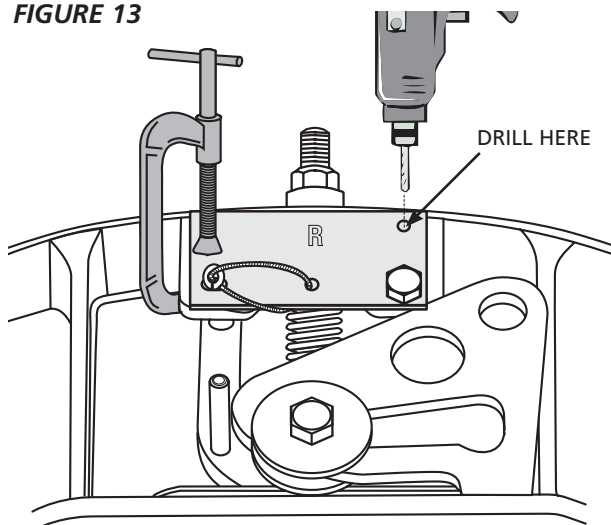

4. Pound the roll pin (ITEM 6) into the newly drilled hole flush with the top of the lug.

FIGURE 14

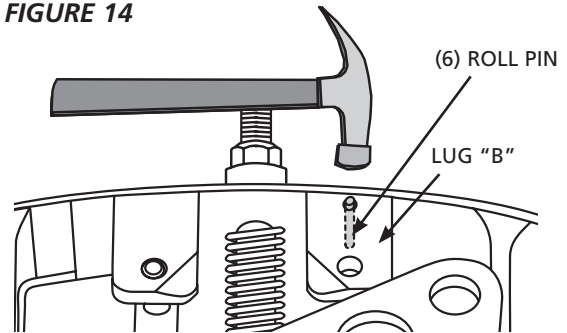

NOTE: Before installing the sensors and harness, make sure the top plate and work areas are free of chips and burrs.

Harness Installation Right-Hand Release

Cam sensor bracket installation

1. Clean and lubricate the cam plate. Install cam sensor bracket under LUG "B". Position HOLE "B" onto the bottom of the roll pin (ITEM 6).

FIGURE 16

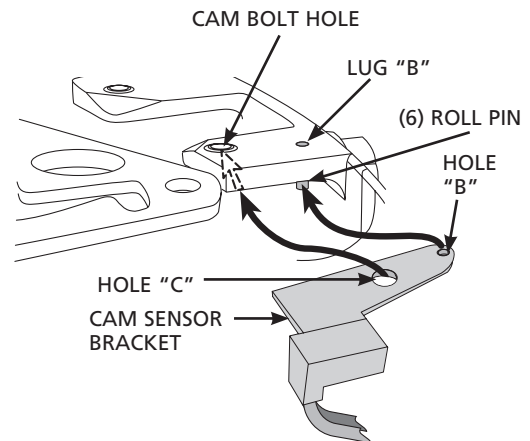

INSTALLATION INSTRUCTIONS

Harness Installation *continued*

- Once the cam sensor bracket is attached to the roll pin, line up **HOLE "C"** (see **FIGURE 15**) with the cam bolt hole. Place the washer (**ITEM 12**) over the cam bolt hole, and rotate the cam plate back into position (see **FIGURE 16**). Re-install the roller (**ITEM 13**) and second washer (**ITEM 12**). Finally, guide the hex head cap screw (**ITEM 14**) through the washer, roller, cam plate, washer, lug, the cam sensor bracket, and washer (**ITEM 20**). Screw the new locknut (**ITEM 15**) onto the hex head cap screw and tighten securely. Check the cam operation for free movement. Clean away excess grease.

FIGURE 17

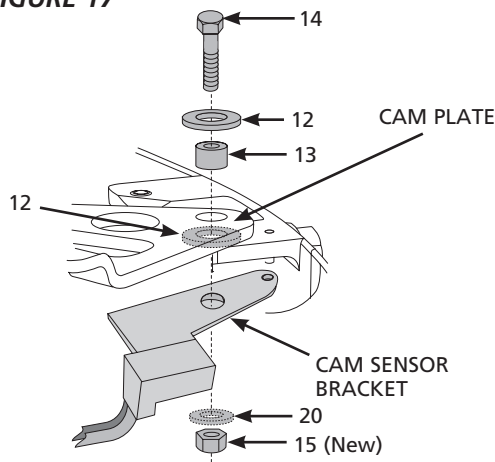

NOTE: When installing the washers (**ITEM 12**), the rounded edge of the washers must always face the cam plate.

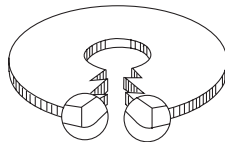

Kingpin Sensor Bracket Installation

- Mount the kingpin sensor bracket to the fifth wheel (see **FIGURE 18**) with the thread-cutting screws (**ITEM 5**). Torque screws to 12 foot-lbs. **Do not** overtighten the screws. **Do not** use air or impact tools.

FIGURE 18

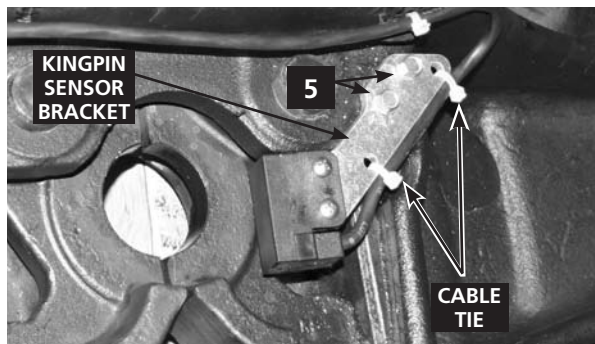

NOTE: The kingpin sensor bracket mounts in the same position for both left- and right-hand release fifth wheels.

- Assemble the cable ties (**ITEM 4**) and spring clips (**ITEM 7**) together before pressing the clips onto the casting as shown in **FIGURE 19**.

FIGURE 19

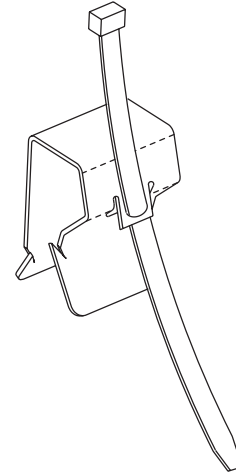

- Route the harness on the fifth wheel as shown in **FIGURE 20**. Use clips (**ITEM 7**), and cable ties (**ITEM 4**) to fasten the harness to the fifth wheel ribs in the locations shown.

FIGURE 20

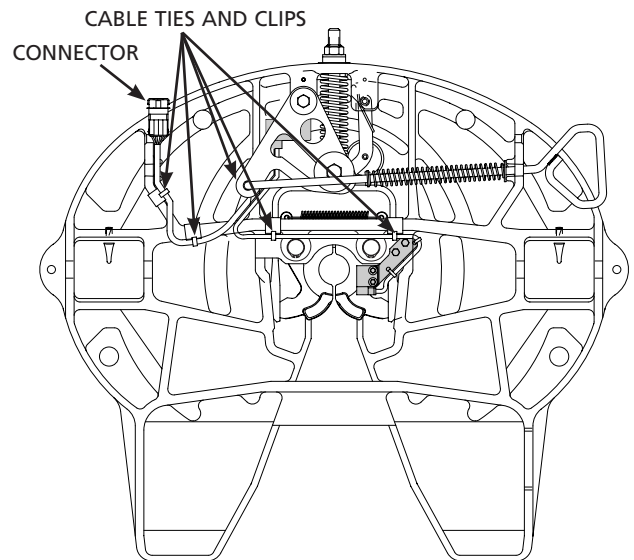

NOTE: A left-hand release fifth wheel is shown here. For a right-hand release, the cam sensor bracket and wiring are mirrored on the opposite side of the top plate.

- Re-install the fifth wheel top plate onto the tractor.

INSTALLATION INSTRUCTIONS

Wire Routing Procedure

1. Mount the display box in the cab so that it is easily visible and accessible to the driver. Clean the dash and display box mounting surfaces with isopropyl alcohol, and allow to air dry. Use the provided, re-closable adhesive fastener (**ITEM 8**) to mount the display box on the dash.
2. Route the cable on the ELI display box (**ITEM 2**) to approximately where the 25' extension cable will enter the cab.

3. Install corrugated loom (**ITEM 11**) around extension cable.
4. Cut one slit into the grommet (**ITEM 16**).
5. Wrap the grommet around the 25' extension cable (**ITEM 1**) in the approximate location where it will enter the cab.

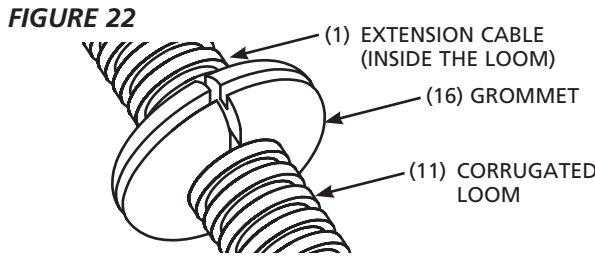
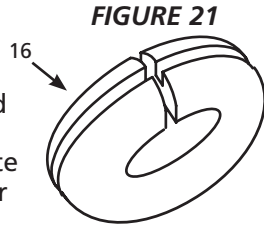

6. Drill a 13/16" diameter utility hole in the cab making sure that there are no obstructions near the drilling area.
7. Run the end (A) of the extension cable with the power lines (see "Parts Breakdown" on page 3) through the utility hole and into the cab..

CAUTION Failure to connect a voltage source that matches the specification on the box will result in a damaged and inoperable display box.

8. Install the 1-amp fuse, which is included with the extension cable (**ITEM 1**) (See **FIGURE 23**):
 - a. Strip 3/8" of insulation from the RED extension cable power wire and the tractor's positive (+) power wire. It is recommended that a switched terminal in the main fuse box be used so that power is supplied when the ignition is turned on.

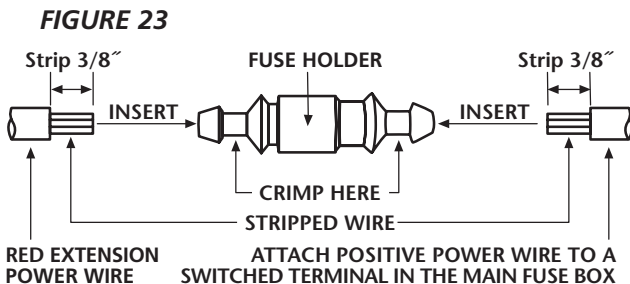

- b. Insert the wires into each end of the fuse holder.
 - c. Crimp the terminal through the fuse holder body.
9. Connect the 2-wire power cable from the extension cable to a 12- or 24-volt power supply. (The back of each display box is marked with 12- or 24-VDC.) Be sure to connect the RED wire with the fuse — as outlined in **STEP 8** — to the positive (+) terminal, and the BLACK wire to the (-) terminal.
 10. Connect the 25' extension cable to the ELI display box cable inside the cab.
 11. Press the grommet (**ITEM 16**) into position in the utility hole. Apply sealant to the grommet and extension cable to prevent moisture intrusion into the cab.
 12. Route the 25' extension cable from the cab to the fifth wheel. See **FIGURE 24**.

FIGURE 24

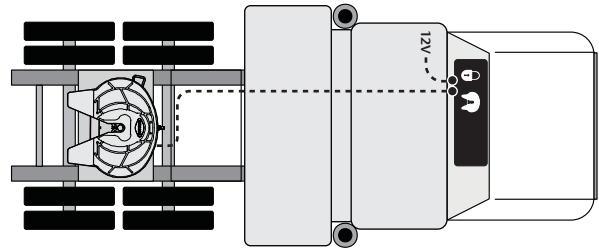

13. Route the wire clear of pinch points.

NOTE: For sliding fifth wheels, be sure to leave enough slack for travel and route the wire clear of pinch points. It can be helpful to route the wire through an existing coiled air line.

14. Secure the extension cable so that it is free of interference from the fifth wheel articulation, brake lines, light cord, drive line etc.
15. Connect the 25' extension cable to the wire harness on the fifth wheel (see **FIGURE 25**).

FIGURE 25

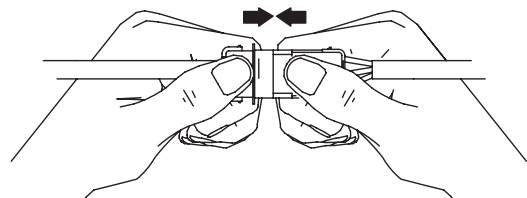

16. Check the operation of the fifth wheel and the Electronic Lock Indicator using lock adjustment tool TF-TLN-5001.

For operating instructions, see SAF-HOLLAND publication XL-FW389-XX.