



# KINGPIN

## REPLACEABLE KINGPIN SPECIFICATIONS and INSTALLATION INSTRUCTIONS

### HOLLAND REPLACEABLE KINGPINS PROVIDE:

- Secure installation.
- Ease and economy of replacement should wear or damage occur to the kingpin.

This series of kingpins is designed specifically for van and enclosed trailers, but can be used on other types of trailers as well. The kingpin design permits economical replacement of the kingpin since it is bolted in place — no expensive rework of the trailer upper coupler.

### STANDARD FEATURES INCLUDE:

1. Secure installation with eight .75" diameter Grade 8 bolts and safety wire lock.
2. Kingpins are made of AISI 8630H alloy steel and hardened to 302-363 BHN. When properly installed, will meet or exceed the performance requirements set by the Society of Automotive Engineers (SAE) and the Truck Trailer Manufacturers Association (TTMA).
3. High impact and wear resistance.
4. Housings are made of AISI 4130H alloy steel for weldability.
5. 100% Brinell hardness tested.
6. 100% magnetic particle tested (to inspect for integrity below the surface).
7. Ultrasonic tested (MS 105, Tightened, C=0).
8. Bolster plate thicknesses are designed into the housings as shown. Only one kingpin, either SAE 2" or 3.5" is required for service parts.

### DIMENSIONS

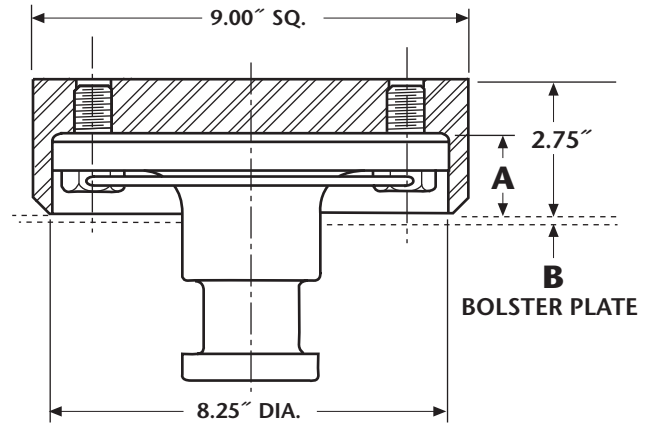

SAE 2.00" KING PIN

2" KINGPIN WITH HOUSING	B BOLSTER PLATE	A COUNTER BORE
KP-0880	.25"	1.56"
KP-0881	.31"	1.50"
KP-0882	.38"	1.44"
KP-0883	.50"	1.31"

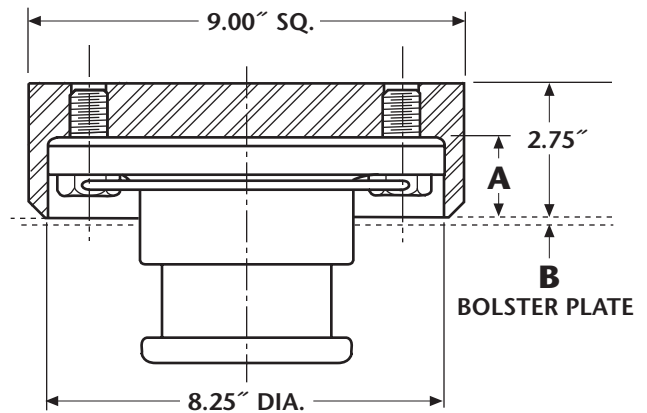

SAE 3.50" KING PIN

3.50" KINGPIN WITH HOUSING	B BOLSTER PLATE	A COUNTER BORE
KP-0884	.38"	1.44"
KP-0885	.50"	1.31"

## HOUSING INSTALLATION RECOMMENDATIONS:

1. The housing is designed for welded installation into the upper coupler assembly. The design of the upper coupler is the responsibility of the installer and must be consistent with the type and capacity of trailer and design loads for the upper coupler.
2. The housing is manufactured from AISI 4130 steel and is weldable by most processes; a low-hydrogen process is required. The "square" external shape of the housing will aid the attachment of required bracing or cross members.
3. Since the inner portion of the housing is accurately machined, a welding procedure which alternates from side to side and which minimizes heat buildup is recommended to avoid distortion. The threaded holes and inner surfaces should also be protected from weld spatter during upper coupler construction.

### PARTS BREAKDOWN

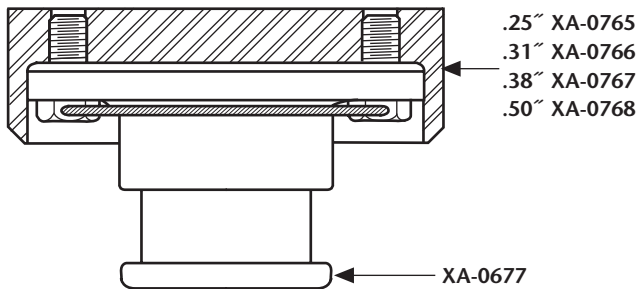
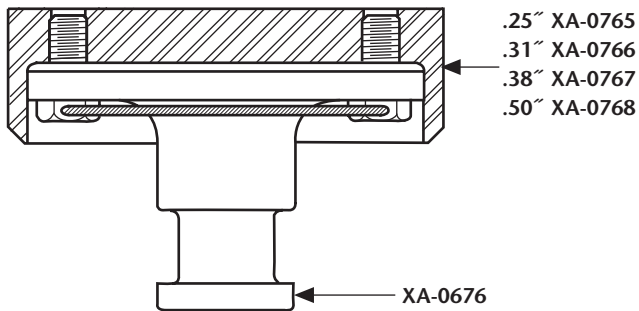

### REPLACEMENT PARTS

**RK-0882**.....Bolt and wire lock kit  
Includes one wire lock and 8 bolts

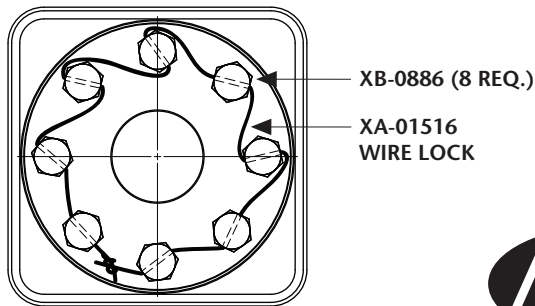

**GO THE DISTANCE.**

Copyright © August 2006 • The Holland Group, Inc.

**Holland USA, Inc. Facilities:**  
Dumas, AR      Muskegon, MI  
Holland, MI      Warrenton, MO  
Monroe, NC      Wylie, TX  
Ph: 888-396-6501      Fax: 800-356-3929

**Holland International, Inc.**  
Holland, MI  
Phone: 616-396-6501  
Fax: 616-396-1511

**Holland Hitch of Canada, Ltd.**  
Woodstock, Ontario • Canada  
Phone: 519-537-3494  
Fax: 800-565-7753

**Holland Equipment, Ltd.**  
Norwich, Ontario • Canada  
Phone: 519-863-3414  
Fax: 519-863-2398

**Holland Hitch of Canada, Ltd.**  
Surrey, British Columbia • Canada  
Phone: 604-574-7491  
Fax: 604-574-0244

www.thehollandgroupinc.com

## KINGPIN INSTALLATION INSTRUCTIONS:

**⚠ WARNING** Before starting installation work, verify that the trailer is securely chocked and supported to prevent the trailer from moving or falling. Failure to do so may result in property damage, personal injury or death.

1. Clean all foreign material from the housing and the kingpin. The application of a VERY THIN coating of rust preventative lubricant to the kingpin prior to installation will aid subsequent removal.
2. Insert the kingpin fully into the housing, taking care to keep it in line to prevent binding. Rotate the kingpin to align bolt holes and install all bolts until hand tight. Continue tightening, alternating across the bolt pattern to insure uniform fit. Tighten all bolts to 180-200 foot pounds. Recheck torque on all bolts a second time.
3. After bolts have been properly torqued, wind wire through holes in bolt heads as shown in *Figure 1*. Feed the wire through the bolt from the center of the kingpin out, moving clockwise from bolt to bolt. Wire should be pulled tight with no slack between bolts. When finished winding, end of wire should be adequately wound with the beginning, so as not to come loose.

**⚠ WARNING** Lock wire must be installed for a secure installation. Do not use without lock wire installed correctly. Failure to correctly install lock wire may allow bolts to loosen during operation causing kingpin failure, resulting in separation of the towed vehicle and subsequent property damage, personal injury or death.

**IMPORTANT:** Lock wire integrity must be checked every 6 months. Replace if damaged, broken or missing, using parts from RK-0882 kit and the preceding instructions.

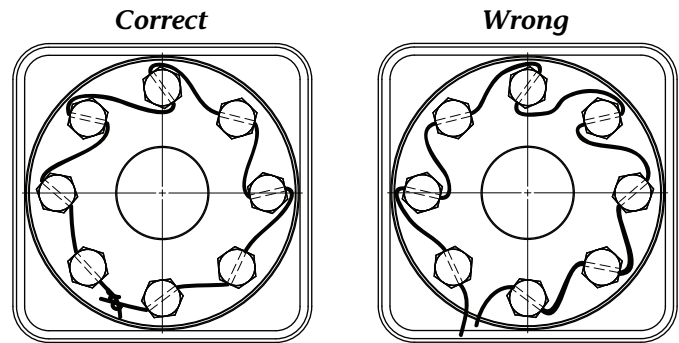

**Figure 1 Lock Wire Installation**

- Wire is tight
- Wire ends are tied
- Wire is wound in correct direction
- Wire is loose
- Wire ends are not tied
- Wire is wound in wrong direction

*These products are covered by Holland's Commercial Products Warranty. Holland reserves the right, without giving prior notice, to change specifications and dimensions as designs are altered or improved.*