



With the Ultimate
Corrosion Protection



HOLLAND CLASSIC LANDING GEAR

YOUR AFTERMARKET LANDING LEG VALUE SOLUTION
WITH PROVEN FEATURES FOR RELIABLE PERFORMANCE



HOLLAND CLASSIC™
LANDING GEAR MERGES
PROVEN AND TRUSTED
TECHNOLOGIES TO CREATE
A REAL WORLD VALUE.



HOLLAND CLASSIC™ LANDING GEAR

SETTING THE STANDARD FOR DEPENDABILITY AND VALUE

The HOLLAND CLASSIC™ Landing Gear merges proven engineering technology with quality and durability to create a new standard in landing gear performance. From the smooth shifting and reliability of the patented Constant Mesh gearbox design, to the durability and toughness of the exclusive FloatingNut™ with Twin-Bulkhead construction; the CLASSIC™ offers a landing gear that was built to carry on the HOLLAND name and tradition of trouble-free performance and exceptional value for years to come.



RELIABLE PERFORMANCE WITH EASY OPERATION

Gearbox Design

- Constant mesh gearing design for durability and long life

High-Strength Ductile Iron Gears

- Ensures impact and fatigue resistance

FloatingNut™ with Twin-Bulkhead Design

- Exclusive FloatingNut feature protects against elevating screw damage, assuring smooth cranking performance
- Reinforced Twin-Bulkhead design for added strength when leg is fully extended

80 ksi Yield High-Strength Steel Leg Tube Material

- Maximum strength upper and lower tube housing for robust performance
- The industry's strongest and lightest weight tube housing material

Standard 5-Year Warranty

- 5-Year warranty covers defects in materials and workmanship

Interchangeable Legs

- Compatible with Kysor-Westran CMS2 Legs

Low Profile Removable Cushion Foot

- Built-in rubber cushion protects the landing gear leg and internal mechanisms from load impact shock

SUPERIOR CORROSION PROTECTION



**BLACK ARMOUR®
IS STANDARD WITH
HOLLAND CLASSIC™**



ECO-FRIENDLY

HOLLAND EXCLUSIVE FEATURES



PATENTED* CONSTANT MESH GEARBOX DESIGN



Eliminates high-to-low shifting problems common to traditional landing gear. Using a crankshaft with a roll pin, only the crankshaft moves to engage the drive gears. No in-or-out movement of drive gears is required - keeping the gears constantly meshed. This design not only provides smooth shifting under loaded conditions, but also prevents slip cranking and difficult high-to-low shifting in cold weather.

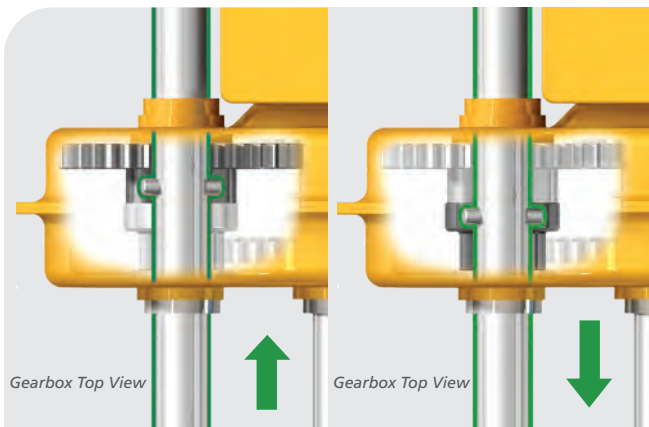

**CRANKSHAFT ENGAGED
IN HIGH DRIVE GEAR**

**CRANKSHAFT ENGAGED
IN LOW DRIVE GEAR**

* Patent Numbers. 4,923,175 & 6,099,016

PATENTED* FLOATINGNUT™ WITH TWIN-BULKHEAD

Twin-Bulkhead design with the FloatingNut feature



When excessive side-load forces occur on the landing gear when fully extended, the FloatingNut allows the lower leg to move within the upper leg housing without causing permanent damage to the elevating screw.

The unique Twin-Bulkheads, above and below the FloatingNut, provide additional structural strength to the top of the lower leg tube.

The FloatingNut™ protects the elevating screw and threads from excessive side loading caused by dock-walk - damage which can cause poor cranking performance or binding. Unique Twin-Bulkheads, above and below the FloatingNut™, further increase structural resistance to side-load forces when landing gear legs are fully extended.

All specified capacities are tested in accordance with AAR M-931.

CLASSIC™ SPECIFICATIONS

CAPACITIES

39,000 lbs. Lift Capacity
 (100 ft./lbs. Input Torque)
 140,000 lbs. Load Capacity
 27,000 lbs. Side Load Capacity

WEIGHT

158 lbs. Cushion Foot Model
 (17" Travel Conventional RCF)
 170 lbs. Sandshoe Model
 (17" Travel Universal Mount
 10" x 10" x 4-1/2" Sandshoe)

NOTE: Weight measurements
 are less hardware.

All specified capacities are tested in
 accordance with AAR M-931.

GEARING

3.2 Turns Per Inch - High Gear
 19.3 Turns per Inch - Low Gear

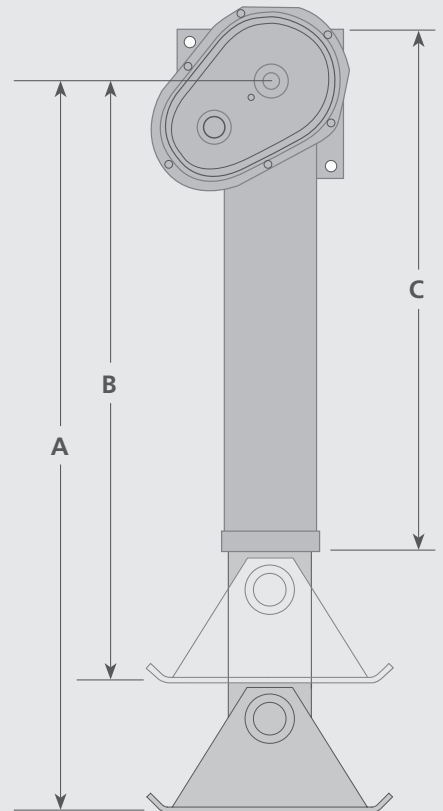

DIMENSIONS	EXTENDED LENGTH (A)	RETRACTED LENGTH (B)	UPPER LEG (C)
LOW PROFILE CUSHION FOOT			
17" Travel (16.87")	46.00	29.00	30.06
19" Travel (19.12")	48.75	29.75	30.06
4.5" SANDSHOE			
17" Travel (16.87")	48.19	31.19	28.06
19" Travel (19.12")	52.69	33.69	30.06
2" SANDSHOE			
17" Travel (16.87")	45.69	28.69	28.06
19" Travel (19.12")	50.19	31.19	30.06

CLASSIC™ ORDERING INFORMATION

EXAMPLE: **LG2 T 0 1 - 7 0 0 0 - XX XXX**

CLASSIC	MOUNTING	SHAFTS	FOOTWEAR	TRAVEL	LEG ASS'Y	RETRACT TUBE	GREASE	LOG NO./ACCY. NO.
LG2	T TWO SHAFT CONSTANT MESH	0 UNIVERSAL	1 SANDSHOE - STD. 4-1/2" X 10" X 10"	7 17"	0 SETS	0 STANDARD	0 STANDARD PACK	CONTACT SAF-HOLLAND FOR SPECIAL OPTIONS AND ACCESSORIES
		2 I-BEAM 6.5" DIA.	3 SANDSHOE - STD. 2" X 10" X 10"		2 RH			
		9 CONVENTIONAL	4 SANDSHOE - STD. 2" X 10" X 12"					
		Z	LOW PROFILE RCF 10" X 10"					

CLASSIC™ ACCESSORIES AND FOOTWEAR OPTIONS

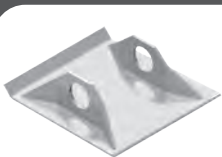

STANDARD DUTY SHOES

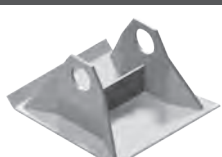

HEAVY DUTY SHOES



SHAFTS AND BRACES



HAND CRANKS



CRANK HANGERS

All landing gear accessories and footwear options can be found in the
 Aftermarket Landing Gear Optional Parts and Accessories Guide (XL-AM10013PM).



TRAILER AXLES AND
SUSPENSION SYSTEMS



COUPLING AND
LIFTING SYSTEMS



SUSPENSIONS FOR
TRUCKS AND BUSES



SUSPENSIONS AND
AXLE SYSTEMS



BUS AIR SUSPENSION
SYSTEMS



V. ORLANDI
TOWING
SYSTEMS



TRAILER AXLES/SUSPENSIONS,
COUPLING AND LIFTING
SYSTEMS

safholland.com

SAF-HOLLAND, Inc.
888.396.6501

SAF-HOLLAND Canada Limited
519.537.3494
Western Canada 604.574.7491

SAF-HOLLAND Mexico
52.55.5456.8641