



*The Original*  
**BINKLEY**™

**SAF** ●

# Z-FRAME ZFX40 SERIES

BINKLEY Z-FRAME SUSPENSION/SLIDER SYSTEM FOR  
CONTAINER CHASSIS AND I-BEAM TRAILERS

# SAF ZFX40 TRAILER SUSPENSIONS

## EXCEPTIONAL PERFORMANCE

The proven Binkley Z-Frame mechanical slider suspension for container chassis and I-beam frame trailers. Equipped with SAF 5.75" drum or disc brake axles for a complete ZFX system configuration.

## PROVEN DESIGNS

SAF trailer axles are the product of the shared expertise and experience of SAF-HOLLAND's global engineering network. From extensive laboratory to rigorous real-world testing, SAF axle designs have been proven against the most challenging conditions. Using state of the art design practices and technologies, SAF-HOLLAND technicians and engineers build performance, durability and value into every mechanical suspension system axle.

**UP TO 50,000 lbs.**  
(25,000 kg) PER AXLE  
**CAPACITY\*\***

*\*\*With properly specified leaf springs*

### QwikRelease™ Pin Pull

The low pull effort of the release handle makes slider adjustment safe, easy and efficient. Patented design allows for single driver slider repositioning and also eliminates the problem of releasing bound-up pins.

### Pin Cage Design

Design enables easy removal of hold-down bolts, and permits entire slide/suspension system to be removed in minutes. Available in two and four pin configurations.

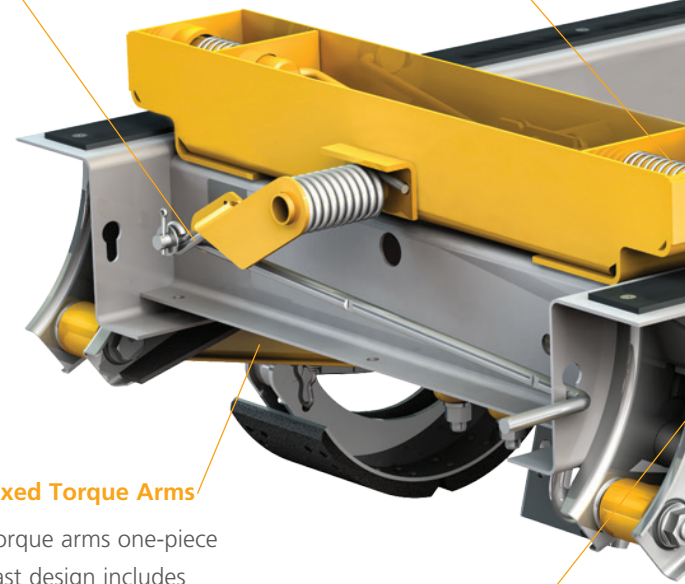

### Fixed Torque Arms

Torque arms one-piece cast design includes robust bushings for increased service life.

### High-Strength Hangers

Hangers are welded at the top and sides for maximum durability and performance.



## BLACK ARMOUR™ IS STANDARD WITH Z-FRAME ZFX SERIES SUSPENSIONS

The BLACK ARMOUR™ metal protection process, unlike a primer, paint or powder coating, chemically bonds with metal to form a protective skin that is impervious to water and anti-icing chemicals. BLACK ARMOUR™ is top coat compatible without pre-sanding and remains flexible to resist gravel impingement. If scraped, BLACK ARMOUR™ inhibits the spread of rust creep.



### Slider Sub-Frame

The sub-frame is constructed from 80,000 lb. yield steel for less weight and greater durability.

### High-Strength Hold-Downs

Hold-downs secure the ZFX40 System to the trailer and is compatible with trailer beam flanges up to 3/4" thick and 6" wide.

### Extra Wide 3" UHMW Pads

Pads provide low breakaway force.

### Hardened Steel Wear Pads

Reduces hanger wear and prolongs life, preventing hanger failure.

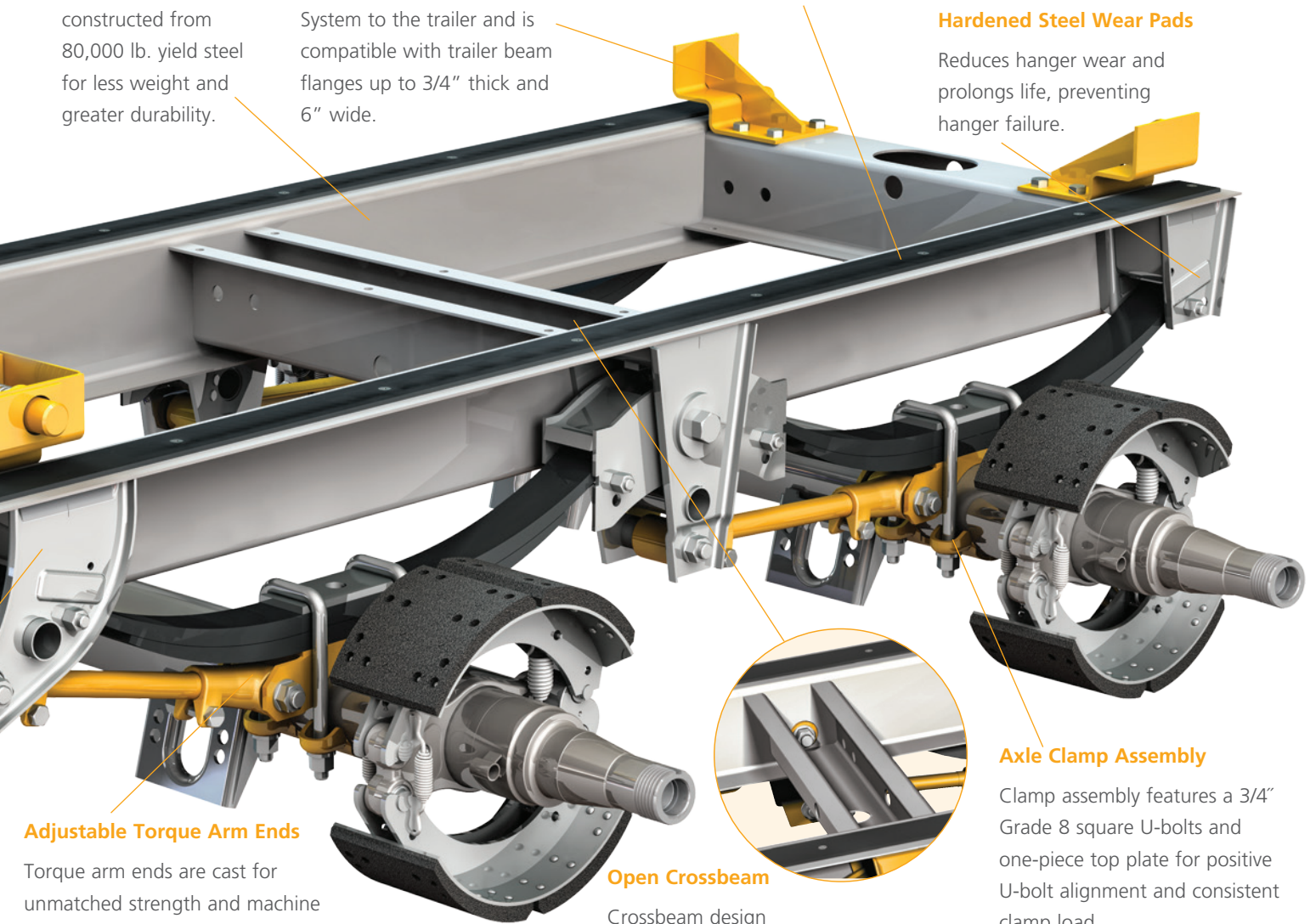

### Adjustable Torque Arm Ends

Torque arm ends are cast for unmatched strength and machine cut full-depth thread.

### Open Crossbeam

Crossbeam design permits easy access to the back side of the center equalizer.

### Axle Clamp Assembly

Clamp assembly features a 3/4" Grade 8 square U-bolts and one-piece top plate for positive U-bolt alignment and consistent clamp load.

## OPTIONAL P89 Series AIR DISC BRAKES

### Two Model Choices to Meet Your Fleet's Specific Needs

The P89 model at a price point that makes sense for fleets of any size. And, the P89 Plus for premium performance. Disc brakes simply provide better performance than drum brakes. They stop shorter for increased safety and reduced maintenance for lower total cost of ownership.



## OPTIONAL SAF SC5 WHEEL ENDS

### Optional SAF SC5 Wheel Ends

Now available with our SAF "SC5" wheel end package that provides an engineered solution for a completely dressed drum brake configuration with a 5-year peace of mind warranty.

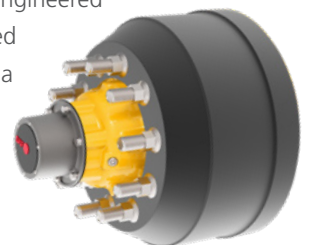

# Z-FRAME ZFX40 SERIES SPECIFICATIONS

## STANDARD SUSPENSION

- Ride heights available from 13.25" to 18"
- Two pin slider repositioning
- Fully assembled
- 36", 38" and 44" standard spring centers
- 7.25" height slider box
- Up to 50,000 lbs. capacity with properly specified leaf springs, axle beams, brakes, and wheel ends

## SUSPENSION OPTIONS

- Four pin slider positioning (90" spacing)

## SUPPORT ITEMS (SOLD SEPARATELY)

- Manual stop bars for 36", 38" and 44" I-Beam centers

Contact a SAF-HOLLAND Trailer Suspension Application Engineer for non-standard configurations and special applications at 888.396.6501.

## STANDARD DRUM BRAKE AXLE PACKAGE

- 5.75" round 71.5" track with ABS blocks
- Tapered spindle axles
- 16.5" x 7" extended service brakes
- 28 spline brake cam, 17.75" length

## DRUM BRAKE AXLE OPTIONS

- 16.5" x 8.625" drum brakes
- Parallel spindle axles
- Prepped for tire inflation
- Dust shields
- 71.5" and other track lengths available
- SC5 dressed drum brake wheel ends
  - Hubs & drums: standard or light weight
  - 5-year warranty
  - Spindle types: Parallel or Tapered
  - Lubrication: synthetic oil or synthetic semifluid grease
- 16.5" x 7" drum brakes only

## OPTIONAL TIRE PILOT PLUS™

Spec Tire Pilot Plus for even more savings – enhanced tire life, fuel efficiency and uptime.



## NO-HOP OPTION

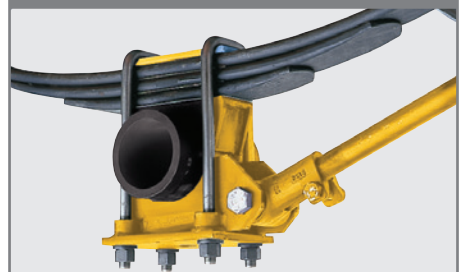

Positioning the torque arms beneath the rear axles keeps the tires on the road during quick, abrupt stops.

# OPTIONAL P89 SERIES AIR DISC BRAKES

The P89 spindle design provides fleets the flexibility to choose the desired wheel end offsets.

**INDUSTRY LEADING  
AIR DISC BRAKE  
WARRANTY**

See XL-AS11002WC warranty statement for complete details.

## P89 –

Proven Design Quality  
with Genuine Value

All the benefits you expect from the world's leading trailer axle disc brake supplier, at a price point that makes sense for commercial fleets of all sizes.

### Featuring:

- Heavy-duty vented rotor
- SAF caliper
- Premium matched set bearings
- Parallel or taper spindle
- 5-Year warranty



## P89 Plus™ –

Premium Performance  
Maintenance Free Design

Featuring the legendary INTEGRAL® rotor/hub and premium sealed bearings for reduced maintenance.

### Featuring:

- INTEGRAL® rotor
- Long-life sealed bearings
- Premium brake chambers
- SAF caliper
- Robust parallel spindle
- Premium spindle nuts
- 7-Year warranty





TRAILER AXLES AND  
SUSPENSION SYSTEMS



COUPLING AND  
LIFTING SYSTEMS



SUSPENSIONS FOR  
TRUCKS AND BUSES



SUSPENSIONS AND  
AXLE SYSTEMS



BUS AIR SUSPENSION  
SYSTEMS



V. ORLANDI  
TOWING  
SYSTEMS



TRAILER AXLES/SUSPENSIONS,  
COUPLING AND LIFTING  
SYSTEMS

[safholland.com](http://safholland.com)

**SAF-HOLLAND, Inc.**

888.396.6501 Fax 800.356.3929

**SAF-HOLLAND Canada Limited**

519.537.3494 Fax 800.565.7753

Western Canada 604.574.7491 Fax 614.574.0244