



PH-200-R

PH-200-R

SPECIFICATIONS



Weight: 44 lbs.



Rigid type pintle hook with air operated plunger, provides a minimum clearance and some shock absorption at the coupling.

18,000 lbs. Maximum Vertical Load
90,000 lbs. Maximum Gross Trailer Weight

SAE J847 Information:

Type I - not applicable. Type II - 90,000 lbs.

⚠ WARNING Maintain adequate vertical (tongue) load to properly control the trailer (generally 10%), but do not exceed the above rated capacities.

TOWING APPLICATIONS:

Trailers, full trailers and doubles operations, especially logging applications, within the stated capacities. For off-road applications, reduce the above capacities by 25% and use in conjunction with a swivel type drawbar.

DRAWBAR EYE DIMENSIONS:

2.44" to 3" I.D. with 1.25" to 1.63" diameter section.

MOUNTING:

- Use a mounting structure of sufficient strength to support the rated capacity of the pintle hook in accordance with SAE J849 and SAE J847, respectively.
- Use the hole pattern described on the reverse.
- Use (4) .75" grade 8 fasteners, properly tightened.
- A Holland XB-165945 air cylinder is recommended for use with Holland pintle hooks.
- Adjustment of Holland's air activated plunger: The Holland XB-165945 air cylinder is preset for mounting structure thickness up to 1.0" with a 1.62" diameter drawbar section. If your mounting structure is different, adjust the plunger as follows:
 - Loosen cylinder rod jam nut (A) as shown in Figure 1.
 - Turn the plunger rod (B) out (counterclockwise) a distance equal to the difference between your mounting structure thickness and 1"

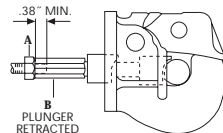

Figure 1

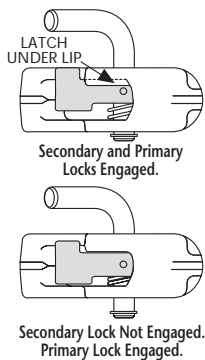

Figure 2

NOTE: Be sure the cylinder rod and plunger rod have .38" minimum thread engagement. (Factory set engagement is approximately 1.38")

- Retighten cylinder rod jam nut (A) securely.
- Mount the air cylinder and plunger assembly, making sure that the air cylinder and plunger assembly are in line with the pintle body. Adjust as required and tighten the cylinder bolts securely.
 - Connect the air supply and check for proper operation.
 - Check the plunger adjustment. When properly adjusted, the plunger should tightly grip a 1.25" round bar (or plunger adjustment toll TF-03147) when energized (see Figure 1) and retract far enough when de-energized to allow easy removal of the drawbar.

OPERATING INSTRUCTIONS:

- Deactivate the plunger by removing air pressure. Check to see that the plunger (XA-04156) is retracted.
- Before using the pintle hook, inspect for proper operation; worn, damaged, or missing parts; and a secure mounting. Correct as required for use.
- Open the latch (XA-03179) by pushing the handle to the left and rotating it up. While keeping the handle rotated up, lift the latch open.
- Position the drawbar eye over the horn of the pintle and lower it into place.

⚠ WARNING DO NOT damage the latch. Be particularly careful with the drawbar when coupling and uncoupling.

- Push the latch closed. Verify that the primary and secondary locks engage. See Figure 2.
- Extend plunger by applying air pressure.

⚠ WARNING Other steps and inspections are also required. Consult OSHA and D.O.T. regulations and American Trucking Association for complete coupling and uncoupling procedures. These cover items such as cargo securement, brakes, lights, safety chains, and other important requirements.

MAINTENANCE:

For proper performance, the following maintenance steps should be performed every 30,000 miles or 3 months, whichever comes first.

1. Clean and check for proper operation. Inspect for worn, damaged or missing parts. Replace as required using only Holland parts.
2. Inspect, in particular, the coupling contact area. Replace when wear exceeds 1/8" (0.125") from the original surface profile.
3. Lubricate latch pivots with a light oil lubricant.
4. Check mounting fasteners for proper torque.
5. Check plunger adjustment. See Item 8 of "Mounting Instructions", described previously.

GENERAL INFORMATION:

1. Do not modify or add to the product.
2. Wear safety goggles during installation, removal and servicing.
3. Never strike any part of the item with a steel hammer.
4. Do not weld on this product without written consent from the factory.



WARNING This equipment must not be used or maintained in a careless manner.

This product is covered by Holland's Commercial Products Warranty. Holland reserves the right, without giving prior notice, to change specifications and dimensions as designs are altered or improved.

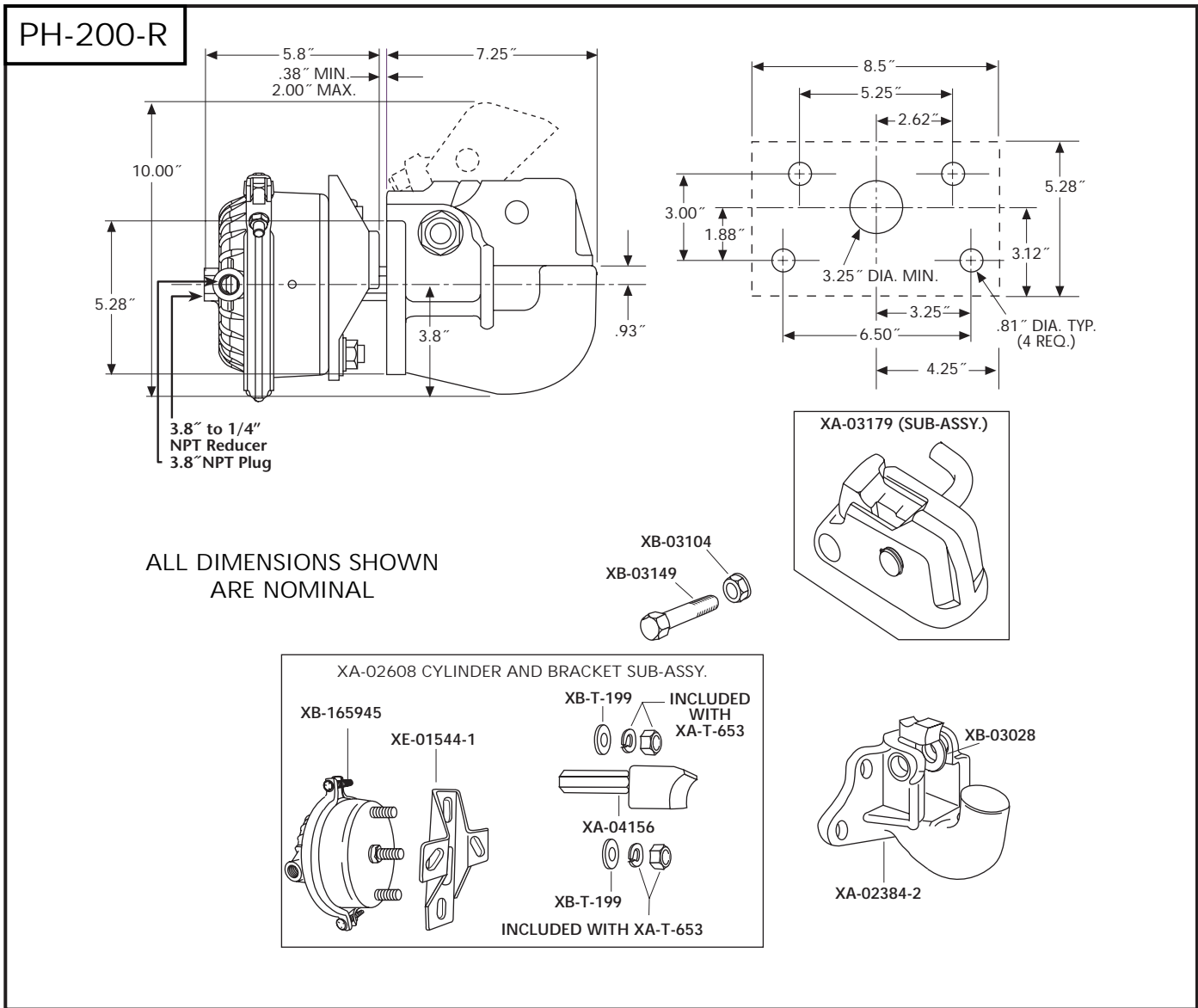

Copyright © April 2007 • The Holland Group, Inc.

Holland USA, Inc. Facilities:
 Dumas, AR Muskegon, MI
 Holland, MI Warrenton, MO
 Monroe, NC Wylie, TX
 Ph: 888-396-6501 Fax: 800-356-3929

Holland International, Inc.
 Holland, MI
 Phone: 616-396-6501
 Fax: 616-396-1511

Holland Hitch of Canada, Ltd.
 Woodstock, Ontario • Canada
 Phone: 519-537-3494
 Fax: 800-565-7753

Holland Equipment, Ltd.
 Norwich, Ontario • Canada
 Phone: 519-863-3414
 Fax: 519-863-2398

Holland Hitch of Canada, Ltd.
 Surrey, British Columbia • Canada
 Phone: 604-574-7491
 Fax: 604-574-0244

www.thehollandgroupinc.com