



# PH-550

## PH-550 SPECIFICATIONS



**Weight:**  
47 lbs.

**⚠ WARNING** Maintain adequate vertical (tongue) load to properly control the trailer (generally 10%) but do not exceed the above rated capacities. This pintle hook must be operated with an air service chamber.

### TOWING APPLICATIONS:

Trailers, full trailers, doubles and triples operations within the stated capacities. For off-road applications, reduce the capacities above by 25% and use in conjunction with a swivel type drawbar.

### DRAWBAR EYE DIMENSIONS:

2.38" to 3" I.D. with 1.62" to 1.75" diameter section.

### MOUNTING:

1. Use a mounting structure of sufficient strength to support the rated capacity of the pintle hook in accordance with SAE J849 and SAE J847, respectively.
2. Use the hole pattern described on the reverse.
3. Use (6) .75" grade 8 fasteners, properly tightened.
4. A Holland XB-165945 air cylinder is recommended for use with Holland pintle hooks.
5. Adjustment of Holland's air-activated plunger: The Holland XB-165945 air cylinder is preset for mounting structure thicknesses of .50" through 1.50" with a 1.62" diameter drawbar section. If your mounting structure is different, adjust as follows:
  - A. Loosen cylinder rod jam nut (A) as shown in *Figure 1*.
  - B. Turn the bullet nose (B) out (counterclockwise) a distance equal to the difference between the mounting structure thickness and 1.50". (It may be necessary to consider drawbar cross section as well).

**NOTE:** Be sure the cylinder rod and bullet nose have .38" minimum thread engagement. (*Factory set engagement is approximately 1.38."*)

- C. Retighten cylinder rod jam nut (A) securely.
6. Mount the air cylinder and bullet nose assembly, making sure that the air cylinder and bullet nose assembly are in line with the plunger (see *Figure 1*). Adjust as required and tighten the air cylinder bolts securely.
  7. Connect the air supply and check for proper operation.
  8. Check the plunger adjustment. When properly adjusted, the plunger should tightly grip a 1.25" round bar or the plunger adjustment tool TF-03147 when energized (see *Figure 1*), and retract far enough when de-energized to allow easy removal of the drawbar.

**FIGURE 1**

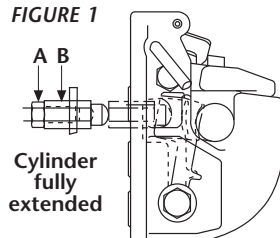

**Rigid type pintle hook with air-operated plunger. Air-operated plunger provides a minimum clearance and some shock absorption at the coupling.**

**25,000 lbs. Maximum Vertical Load**  
**100,000 lbs. Maximum Gross Trailer Weight**  
**(130,000 lbs. Tensile)**

### SAE J847 Information:

Type I - 130,000 lbs. Type II - 105,000 lbs.

### OPERATING INSTRUCTIONS:

1. Deactivate the plunger by removing the air pressure. Check to see that the plunger (XA-05494) is fully retracted.
2. Before using the pintle hook, inspect for proper operation, worn, damaged or missing parts and secure mounting. Correct as required before use.
3. Remove the safety lock pin (C) as shown in *Figure 2*.

**FIGURE 2**



4. Pull the lock handle (D) (see *Figure 3*) until lock (E) is free of the undercut of the base unit. Rotate handle (D) upward.
5. While holding handle (D) up, lift latch (F) so it contacts lock (E) (see *Figure 4*). Release handle (D) until lock (E) captures latch (F).
6. Position the drawbar eye over the horn of the pintle hook and lower into place.

**FIGURE 3**

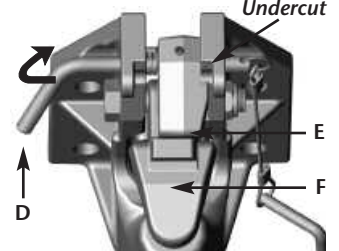

**⚠ WARNING** DO NOT damage the latch. Be particularly careful with the drawbar when coupling and uncoupling.

7. Rotate the lock handle (D) upward and allow latch (F) to disengage from lock (E). Lower latch (F) until it contacts the horn area on the pintle hook body.
8. Release handle (D), making sure that lock (E) engages in top of latch (F) and also that latch (E) engages the undercut of the pintle hook body as shown in *Figure 3*.

**FIGURE 4**

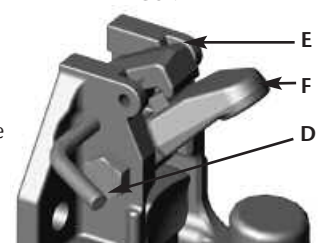

9. Insert the self-locking pin (C) as shown in *Figure 2*.
10. Extend the plunger by applying air pressure.

**⚠ WARNING** Other steps and inspections are also required. Consult OSHA and D.O.T. regulations and American Trucking Association for complete coupling and uncoupling procedures. These cover items such as cargo securement, brakes, lights, safety chains and other important requirements.

## MAINTENANCE:

For proper performance, the following maintenance steps should be performed every 30,000 miles or 3 months, whichever comes first.

1. Clean and check for proper operation. Inspect for worn, damaged or missing parts. Replace as required using only Holland parts.
2. Inspect, in particular, the coupling contact area. Replace when wear exceeds 0.125" from the original surface profile.
3. Lubricate latch pivots with a light oil lubricant.
4. Check mounting fasteners for proper torque.
5. Check plunger adjustment. See Item 8 of "Mounting Instructions," described previously.

## GENERAL INFORMATION:

1. Do not modify or add to the product.
2. Wear safety goggles during installation, removal and servicing.
3. Never strike any part of the item with a steel hammer.
4. Do not weld on this product without written consent from the factory.



**This product must not be used or maintained in a careless manner.**

This product is covered by Holland's Commercial Products Warranty.

Holland reserves the right, without giving prior notice, to change specifications and dimensions as designs are altered or improved.

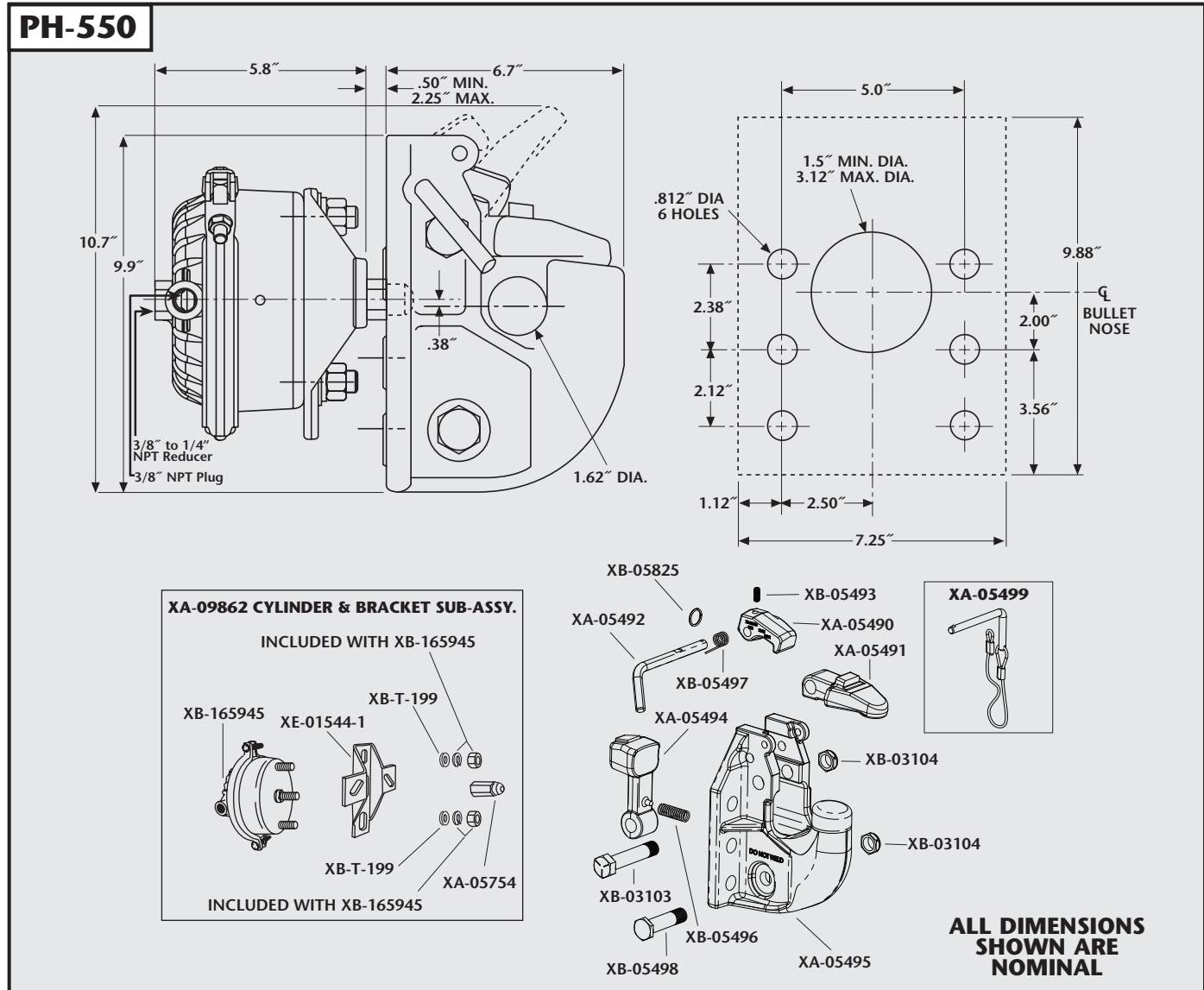

**GO THE DISTANCE.**

Copyright © April 2006 • The Holland Group, Inc.

### Holland USA, Inc. Facilities:

Dumas, AR Muskegon, MI  
Holland, MI Warrenton, MO  
Monroe, NC Wylie, TX

Ph: 888-396-6501 Fax: 800-356-3929

### Holland International, Inc.

Holland, MI  
Phone: 616-396-6501  
Fax: 616-396-1511

### Holland Hitch of Canada, Ltd.

Woodstock, Ontario • Canada  
Phone: 519-537-3494  
Fax: 800-565-7753

### Holland Equipment, Ltd.

Norwich, Ontario • Canada  
Phone: 519-863-3414  
Fax: 519-863-2398

### Holland Hitch of Canada, Ltd.

Surrey, British Columbia • Canada  
Phone: 604-574-7491  
Fax: 604-574-0244

www.thehollandgroupinc.com