



COUPLER PRODUCTS

LATCH REPLACEMENT PROCEDURE



RK-10545

For all PH-210 / PH-310 / PH-410 and PH-775 NoLube Series Pintle Hooks Without a Pin and Lanyard

VERIFY KIT CONTENTS

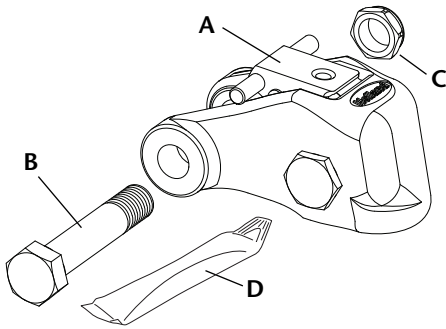

Kit Contains:

ITEM	PART NO.	QTY
A	XA-10545-1	1
B	XB-10537	1
C	XB-03104	1
D	Never-Seez®	1

Never-Seez® is a registered trademark of Bostik, Inc.

PRODUCT IDENTIFICATION

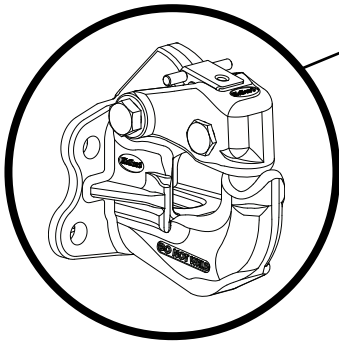
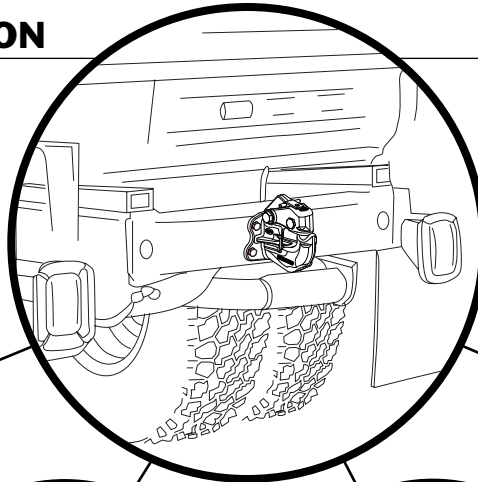

PH-210 SERIES HOOKS
For additional information, reference XL-PH340

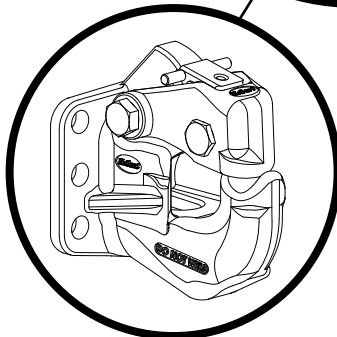

PH-310 SERIES HOOKS
For additional information, reference XL-PH341-ES

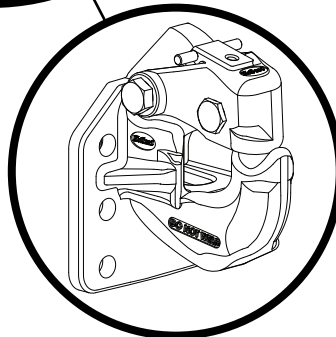

PH-410 SERIES HOOKS
For additional information, reference XL-PH342

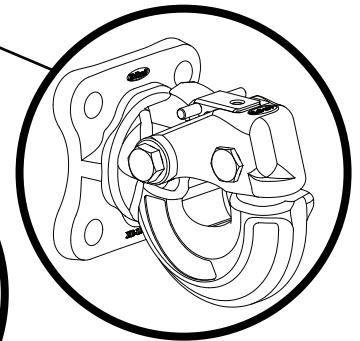

PH-775 SERIES HOOKS
For additional information, reference XL-PH334-ES

PROCEDURE

1. Remove and discard the nut, pivot bolt, and latch assembly.

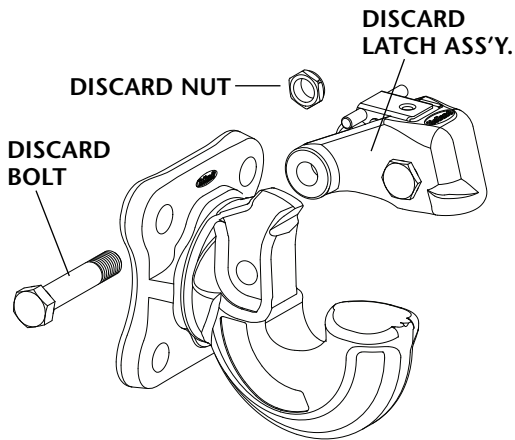

2. Apply Never-Seez® to entire shaft of the new pivot bolt (not on threads).

CLEAN THE BOLT AND APPLY NEVER-SEEZ® HERE

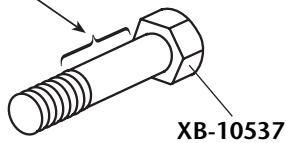

3. Install the new latch assembly using the new pivot bolt and nut.

Torque Specifications:

Torque the lock nut (XB-03104) to 75-100 ft-lbs.

WARNING DO NOT reinstall a removed lock nut. Always install a new lock nut when removing or replacing latch assembly. A reinstalled nut may not retain properly and could result in an unintended trailer separation.

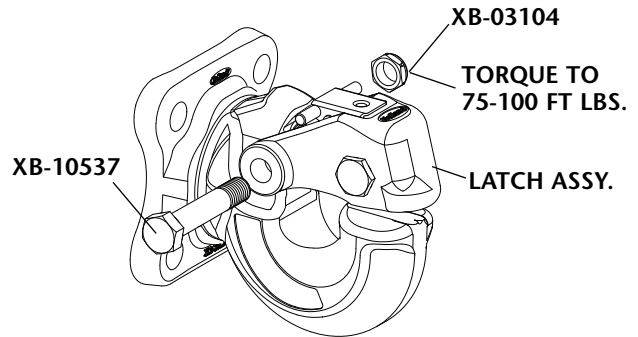

4. Check the latch for proper operation. It should open and close freely. When closed, the lock handle (A) will rotate and move up until it is flush with the top of the latch.

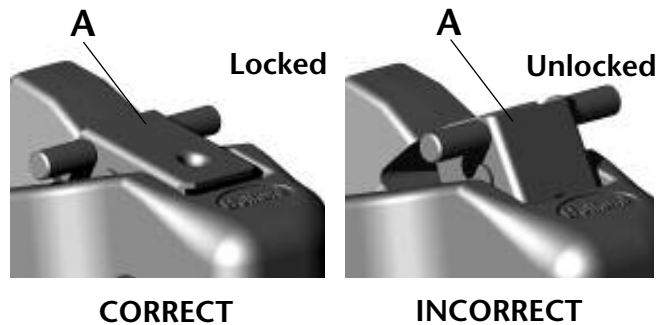

SAF-HOLLAND USA, Inc.
888.396.6501 Fax 800.356.3929

SAF-HOLLAND Canada, Ltd.
519.537.3494 Fax 800.565.7753
Western Canada
604.574.7491 Fax 604.574.0244

SAF-HOLLAND International, Inc.
616.396.6501 Fax 616.356.1511