

PH-10RP51

PH-10RP51 SPECIFICATIONS

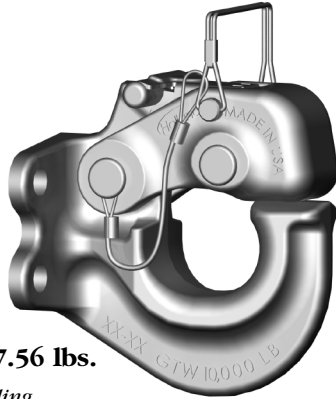

Weight: 7.56 lbs.

Patent Pending

IMPORTANT SAFETY INFORMATION:

Maintain adequate vertical (tongue) load to properly control the trailer (generally 10%) but do not exceed the above rated capacities.

DO NOT damage the latch. Be particularly careful with the drawbar when coupling and uncoupling.

Other steps and inspections are also required. Consult OSHA and D.O.T. regulations and American Trucking Association for complete coupling and uncoupling procedures. These cover items such as cargo securement, brakes, lights, safety chains, and other important requirements.

This equipment must not be used or maintained in a careless manner.

GENERAL INFORMATION

1. Do not modify or add to the product.
2. Wear safety goggles during installation, removal and servicing.
3. Never strike any part of the item with a steel hammer.
4. Do not weld on this product.

This product is covered by SAF-HOLLAND's Commercial Products Warranty. SAF-HOLLAND reserves the right, without giving prior notice, to change specifications and dimensions as designs are altered or improved.

TOWING APPLICATIONS

Trailers and equipment designed for over-the-road towing within the stated capacities. For off-road applications, reduce the capacities above by 25% and use in conjunction with a swivel type drawbar.

DRAWBAR EYE DIMENSIONS

Compatible with drawbar eyes with the following dimensions:

Internal eye diameter from 2-3/8" (2.375") to 3" (3.0")

Drawbar eye cross sections from 1-1/4" (1.250") to 1-5/8" (1.625") diameter

Rigid type pintle hook.

2,000 lbs. Maximum Vertical Load

10,000 lbs. Maximum Gross Trailer Weight

Tested in accordance with SAE J847 (Type II)

MOUNTING

1. Use a mounting structure of sufficient strength to support the rated capacity of the pintle hook in accordance with SAE J847 and SAE J849.
2. Use the hole pattern described on the reverse.
3. Use (4) 1/2" Grade 8 fasteners, properly tightened — recommended minimum torque is 60 ft-lb.

OPERATING INSTRUCTIONS

1. Before operating, inspect for proper operation, worn, damaged or missing parts and a secure mounting. Correct as required before use.
2. Make sure the pintle is in the proper coupling position as shown (with latch on top).
3. Open latch (A) by removing lock pin (B) and lifting the lock handle (C).
4. Position the drawbar eye over the horn of the pintle and lower into place.
5. Push the latch (A) closed and insert the lock pin (B) in the hole provided in the latch.

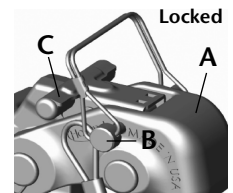

CORRECT

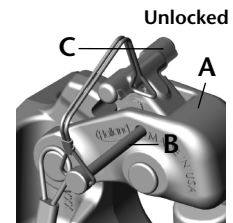

INCORRECT

MAINTENANCE

For proper performance, the following maintenance steps should be performed every 30,000 miles or 3 months, whichever comes first.

1. Clean and inspect for worn, damaged or missing parts. Replace as required using only SAF-HOLLAND Original Parts.
2. Inspect the hook (XA-11047) and latch (XA-10632-1 sub-assembly) in areas where contact is made with the drawbar for excessive wear. Replace the hook when wear exceeds 1/8" (0.125") from the original surface profile.
3. With the latch closed, measure the gap between the hook and the latch while lifting up on the latch. Replace the latch (XA-10632-1 sub-assembly) when the gap exceeds 1/4" (0.25"). See Detail A.
4. Check mounting fasteners as instructed in Step 3 of the "Mounting" section.

PH-10RP51

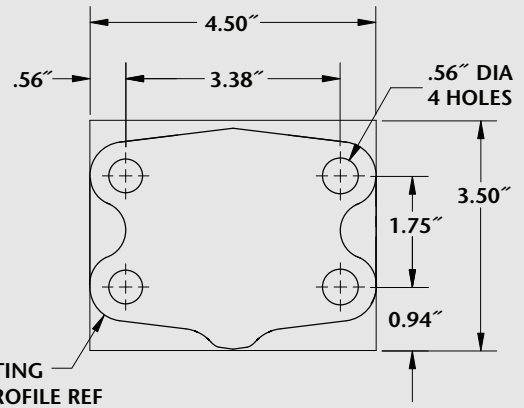
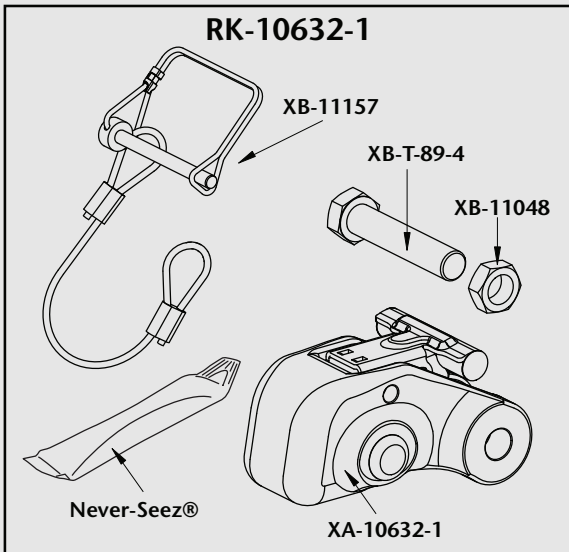
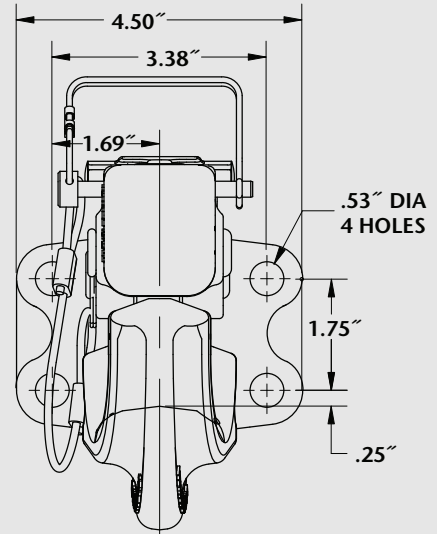
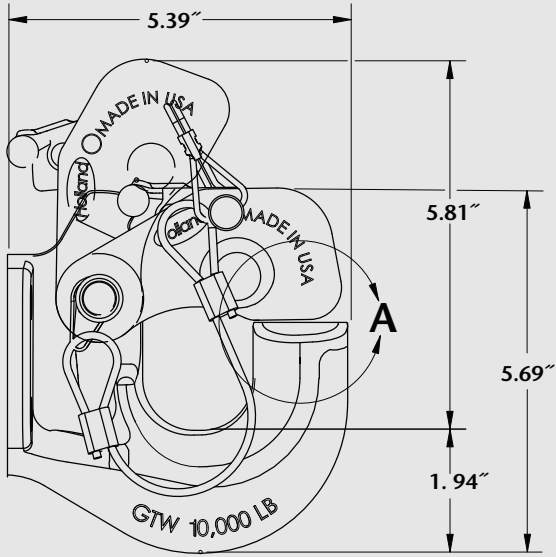

REQUIRED MOUNTING INTERFACE

