

SAF Trailer Drum Brake Axles

Camshaft Enclosure Design Improvement

Attention

SAF-HOLLAND is pleased to introduce a series of design improvements to the camshaft enclosure option on all X-Series 5-3/4" axles.

The main tube thickness has been increased from 0.125" to 0.219" and a larger 1/8" NPT grease purging hole has been added. The mounting bracket has been redesigned to use four (4) attachment bolts, and larger/longer welds are used to secure the mounting plate to the tube.

This new camshaft enclosure system is used on all CBX and CBXu air ride suspensions manufactured after September 2016. The camshaft enclosure is covered by a 3-year parts and 1-year labor warranty.

Retro-fit kits are available to convert older generation camshaft enclosures to this new design:

- Short Cams (17-3/8"): 51830041
- Medium Cams (20-3/8"): 51830042
- Long Cams (23-7/8"): 51830043
- Extra Long Cams (26-7/8"): 51830044

If you have any questions or require additional product assistance, please contact your SAF-HOLLAND sales or service representative at 888.396.6501, or visit our website at www.safholland.us

Figure 1 – New Design

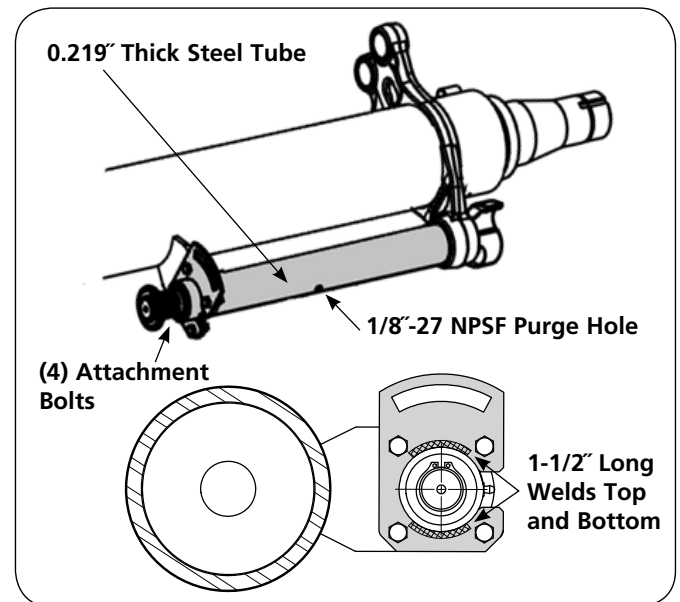

Figure 2 – Old Design

