

Maintenance and Repair Manual for SAF Disc Brakes

SK RB 9022 H with HALDEX brake calliper

SK 1000 ET 120



Edition 01/2006



Manufacturer.....

Address.....

Body type.....

Chassis no.....

Year of manufacture

Registration date.....



Spare parts service for SAF axles and suspension systems

When ordering spare parts, correct type designations are essential.

Please enter the vehicle identification data in the type plates shown below so that correct information is available when required.



Identification of axles without type plate
Production No. of axle on right of stub axle as seen in direction of forward travel.

Type plate (on the inside of the trailing arm or axle beam)

SAF		OTTO SAUER ACHSENFABRIK KEILBERG	
		D-63854 BESSENBACH / G E R M A N Y	
TYP			
Ident.-No. / Prod.-No.			
zul. Last kg perm. cap. charge adm.	STAT.	TECH.	v max. km/h max. speed vitesse maxi.
TDB-No.	Grundtyp		

This manual is intended for the technical workshop personnel responsible for maintenance and repair.

	Page
SAF axle identification.....	2
Notes.....	4/33-34
A) General safety instructions	5
B) Maintenance instructions	
Maintenance instructions for SAF axles SK RB 9022 H - SK 1000 ET 120.....	6
Maintenance schedule for SAF axles SK RB 9022 H - SK 1000 ET 120.....	7
Brake testing (fault-finding procedure)	8
Adjuster check	9
Brake pad check	10
Special notes.....	11
C) Spare part illustrations/spare part designation	
Spare part illustration and spare part designation SK RB 9022 H - SK 1000 ET 120	12-13
D) Installation instructions	
Repairing the brakes.....	14-20
Replacing the tappets with tappet boots	21
Installing the tappets with tappet boots	22
Replacing the guide pin/slides.....	22-24
Installing the guide pin/slides.....	24-26
Replacing the brake cylinder.....	26
Replacing the tensioning unit	27
Installing the new tensioning unit.....	27-28
Synchronising the adjustment screws of the tensioning unit	29
Overview of hub unit components	30
E) Service tools	31
F) Bolt / Nut torque values	32

The item numbers indicated are given only for identification and to distinguish between different versions.

Use the part numbers from the valid spare parts documents for identification of spare parts.

SAF axles and suspension units are subject to continuous further development; the data and drawings contained in the manual may therefore differ from the details given in the operating permit.

The contents of the manual does not constitute the basis for a legal claim.

Reprinting, reproduction or translation in whole or in part is not permitted.

The issue of this publication invalidates all earlier maintenance and repair manuals.

Note: We wish to thank HALDEX for providing various illustrations!

Please observe the following safety instructions in order to maintain the operational and road safety of your SAF axles and suspension systems:

1. The wheel contact surfaces between the wheel disc and wheel hub and the wheel nut contact surface at the wheel disc must not be additionally painted. The contact surfaces must be clean, smooth and free from grease. Failure to observe this may result in the wheel coming loose. Any additional instructions of the wheel manufacturer must also be observed.
2. Only the wheel and tyre sizes approved by the trailer builder may be used. The tyres must always have the specified inflation pressure.
3. The brake systems of the tractor and the trailer/semi-trailer must be synchronised by means of a tractor/trailer brake synchronisation not later than 5,000 km after the initial start of operation of the trailer/semi-trailer in order to ensure a safe and uniform braking behaviour and uniform brake pad wear. Tractor/trailer brake synchronisations should be carried out by appropriately qualified and equipped brake workshops.

The use of an additional braking system, such as a trailer anti-jackknife brake is forbidden by law on vehicles with type approval after January 1999.

4. Before starting a journey, ensure that the maximum permissible axle load is not exceeded and that the load is distributed equally and uniformly.
5. On trailers with air suspension, ensure that the air bags are completely filled with air before starting the journey. Incompletely filled air bags may result in damage to axles, suspension, frame and superstructure and impair road safety.
6. Ensure that the brakes are not overheated by continuous operation.

With drum brakes, overheating can result in a hazardous deterioration in the braking efficiency.

With disc brakes, overheating can result in damage to surrounding components – in particular the wheel bearings. This can result in a significant deterioration in road safety, e.g. failure of wheel bearings.

7. The parking brake must not be immediately applied when the brakes are hot, as the brake discs and brake drums may be damaged by different stress fields during cooling.
8. Use the supports provided when loading and unloading in order to avoid damage to the axle.
9. Observe the operating recommendation of the trailer builder for off-road operation of the installed axles and suspension systems.

The SAF definition of OFF-ROAD means driving on non-asphalted / non-concreted routes, such as e.g. gravel roads, agricultural and forestry tracks, on construction sites and in gravel pits.

Off-road operation of SAF axles and suspension systems not designed for the purpose may result in damage and hence to an impairment of road safety.

10. SAF axles and suspension systems require continuous care, service and maintenance in order to maintain operational and road safety and to be able to recognise natural wear and defects in good time.

The daily inspection of the trailer for road safety before starting the journey is one of the driver's obligations.

SAF recommends that at least the inspections and maintenance operations described on page 6 should be carried out.

We recommend the use of original SAF spare parts.

A close-knit service network of SAF partner companies is available for the technical support of the SAF axle and suspension systems and for the supply of original SAF spare parts (see rear cover or on the Internet under www.saf-axles.com).

Updates will be published as necessary on the Internet under www.saf-axles.com.

SK 1000 Disc/ET 120 SK RB 9022 H - SK 1000 ET 120

Maintenance intervals		After first 5,000 km or	Periodic checks		
			every 30,000 km	every 75,000 km	every 150,000 km
whichever comes first	Mileage intervals >				
	Time intervals >	After first month	every 3 months	every 6 months	every 12 months

Mechanical check

Note: Be sure to retighten wheel nuts to the prescribed torque after the first 50 km and 150 km (and after every wheel removal).

Visual and safety inspection

Hub unit maintenance-free. Visual inspection for grease leaks.				●
Inspect the brake calliper guide system. Check for free movement and sliding action.				●
Check rubber dust covers for cracks and damages. Check adjuster cap for correct seating.				●
Inspect the brake pad thickness at regular intervals (e.g. when ever tyre pressure is checked) but at least every 3 months.		●		
Inspect the brake disc for cracks.			●	
– Perform general annual inspection (brakes, air bags, tyres, etc.)				●
– Perform general annual safety check (tractor/ (semi-) trailer brake compatibility, ABS etc.)				●

Special service conditions

Vehicles with long standing periods:

service at specified time intervals

Vehicles used under extreme conditions:
e.g. construction site operation, multi-shift operation

shorten the service interval to 6 months /
75,000 km

Warranty claims will only be accepted as long as the operating and maintenance instructions have been complied with and if SAF approved spare parts have been fitted.

NOTE!

If the sealmark on the hub nut is broken before the end of the 1,000,000 km this will invalidate all warranty coverage unless the repair works have been carried out in an SAF-authorized workshop.

SK 1000 Disc / ET 120 SK RB 9022 H - SK 1000 ET 120

Hub Unit

Hub Unit maintenance free.

Inspect for signs of wear at each brake disc change (e.g. escape of grease).

After brake relining, observe the following points:
Inspect the seals on the brake calliper.

Never use high-pressure cleaners or cleaning fluids on the brake disc or hub unit.

Clean stub axle of any old grease and apply fresh SAF fitting paste.

Lubricant specifications:

Copper paste
SAF Part No. 4 387 0020 00

Grease:
SAF Part No. 4 387 0018 00

Sealing compound:
SAF Part No. 4 387 0019 00

Stub axle:
SAF Part No. 4 387 0015 06
SAF fitting paste

Tightening the hub nut

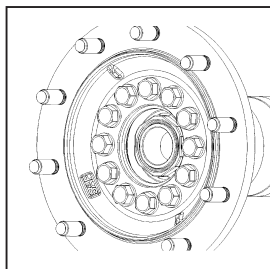

On LH side as seen in direction of travel –
LH thread

On RH side as seen in direction of travel –
RH thread

Tightening torque 900 Nm. Each hub unit must be rotated smoothly at least twice while tightening the bolts.

Hub nuts with LH thread are marked:
Groove on the face.

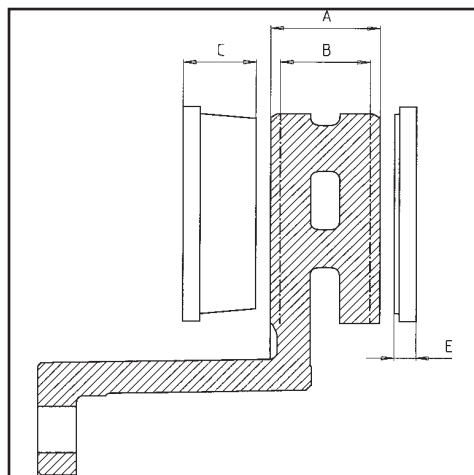

NOTE!

Failure to observe these instructions may result in an accident risk!
Worn brake linings or excessively worn brake discs result in a reduction in the braking efficiency or in a complete failure of the brake system.

Brake type	Thickness of brake disc "A"	Wear limit of brake disc "B"	Thickness of linings "C"	Lining wear "E"	Disc diameter in mm	No. of brake pads per axle
SBH 2243	45	≤37	30	11	430	4

Item No.		Tightening torque (Nm)	Spanner size (W.A.F.)	Hexagon	
				outside	inside
44	Wheel flange mounting M18 x 1.5 x 75 or 65	450	27	X	–
44	TORX screw with head M18 x 1.5 x 75 or 65	Tightening process: pre-tighten to 50 Nm diagonally, turning angle of 90° diagonally tightened (1 1/2 nut corners)	External torx E24	–	–
Caution! Bolts must not be oiled!					
	Guide pin bolts on brake calliper 4 hex. socket head screws M14 - 10,9	220 ^{±20}	External torx E18	–	–
	Brake chamber/spring brake chamber 2 hex. nuts M16 x 1.5	210	24	X	–
	Brake calliper mounting on axle M16 x 1.5 x 55	290	24	X	–
63.2	Lining retainer hoop fixing screws	20 ^{±3}	13	X	–

Assembly tools

Hub nut wrench

Puller for hub unit

Tool box compl.

3/4" spanner external torx shape

SAF Part No.

2 012 0023 01

4 434 3822 00

3 434 6000 00

4 434 3824 00

Brake testing

Fault-finding procedure

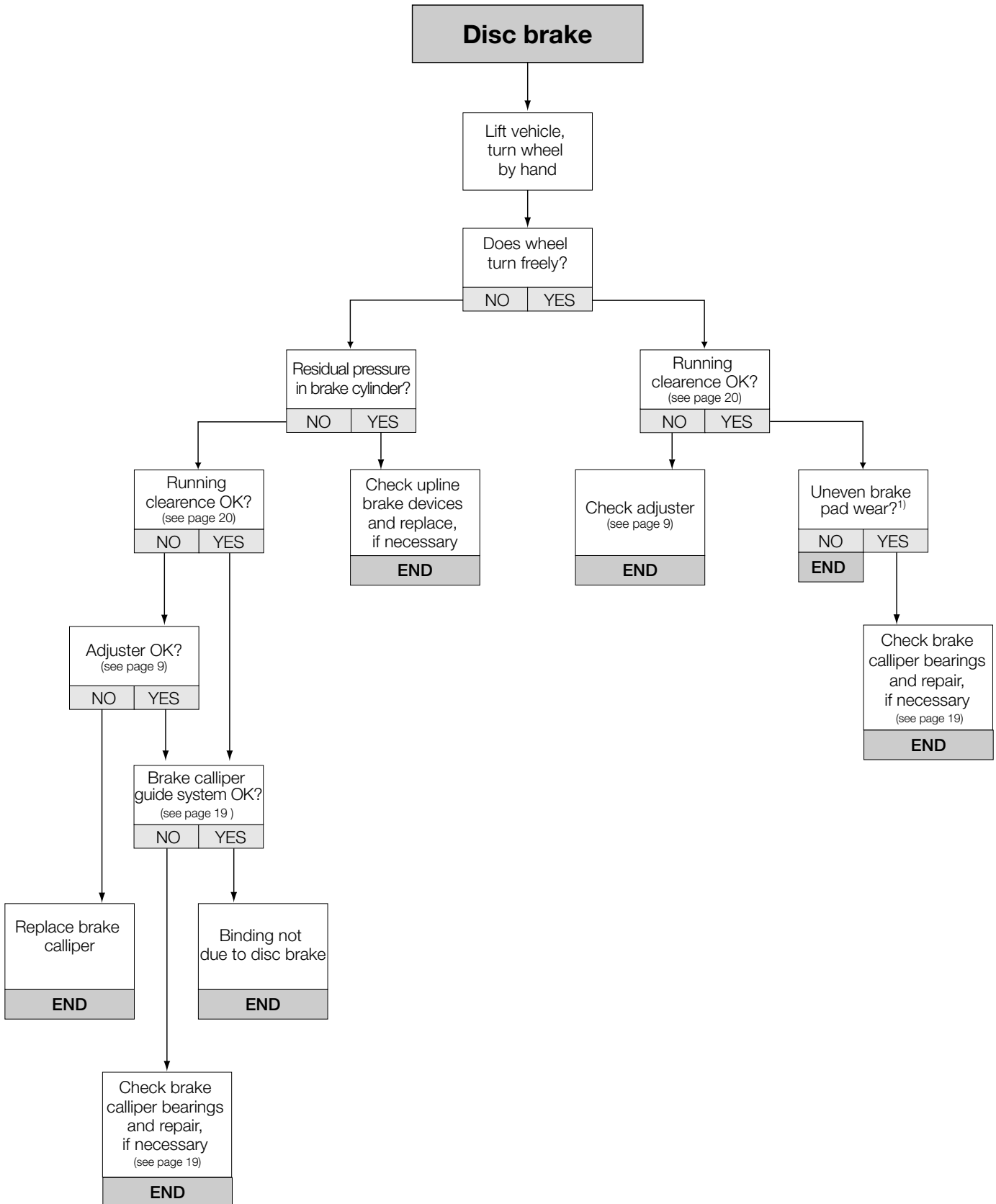

¹⁾ Difference between wear of inboard and outboard pad, and diagonal wear ≤ 2 mm.

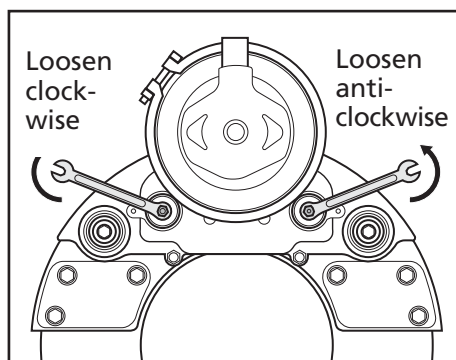

Functionality test

Remove the plugs. Loosen the brake. Using an SAF 8 mm ratchet wrench to turn the return shaft by approx. $\frac{3}{4}$ revolution.

Note that loosening the brake can be carried out in both clockwise and anti-clockwise directions independent of which of both holes the adjusting rods are situated in. If the disc brake can be seen with the membrane cylinder at the top and from the side, from which the hexagon of the adjuster rod is reached, then the adjuster rod is to be turned ant-clockwise if it is situated in the right hand hole, and clockwise if it is situated in the left hand hole.

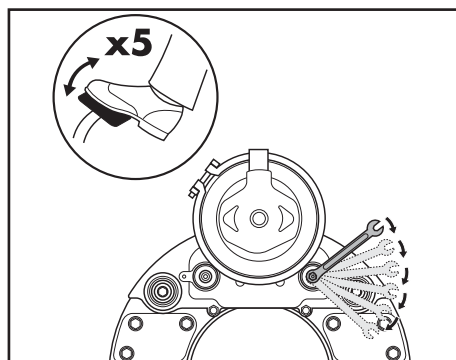

Do not remove the SAF ratchet wrench. Actuate the brakes approx. 5 times. The ring spanner must move after each actuation of the brake = the automatic adjustment is working correctly.

Note!

The area in which the SAF ratchet wrench moves must be free!

Should the SAF ratchet wrench turn backwards and forwards or not at all, the tensioning unit is defect and must be replaced (see pages 27 - 28).

Carry out basic adjustment (see page 29).

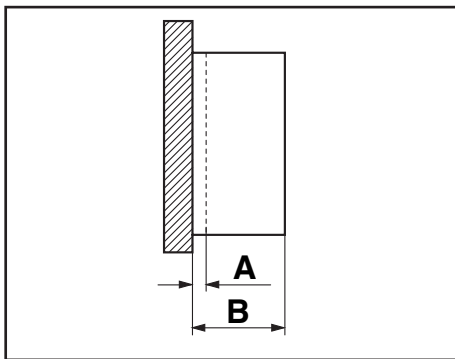

Brake pad check

Caution!

Observe the wear limits of the brake pads.

Check the thickness of the brake pads for compliance with the legal requirements at regular intervals, but at least every three months, depending on the operation of the vehicle.

A = Minimum residual lining thickness 2 mm

B = Total lining thickness of new pads 21 mm

When the residual lining thickness is $A \leq 2$ mm, replace the brake pads.

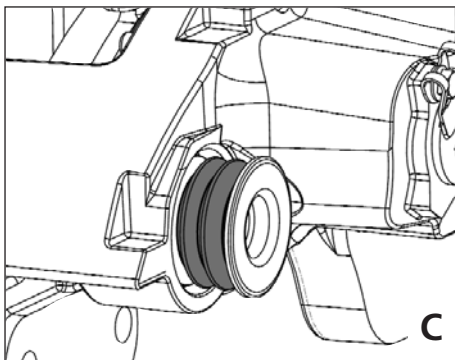

Wear indicator

The amount of life left in the linings can be determined at the point of the inner brake calliper guide when the wheels are still fitted.

When new, the rubber sealing element can be seen with both lips (position C).

When worn, the brake calliper is in position D. In this case a check is necessary on the brake linings and brake discs with the wheels removed.

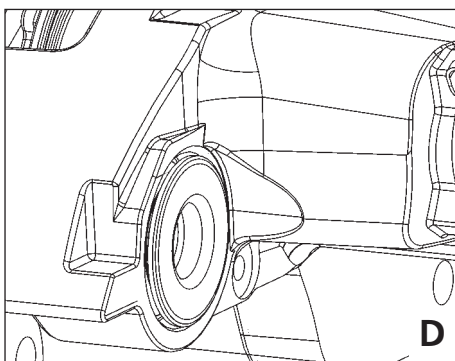

Special notes

Storage instructions

During storage outdoors, ensure that moisture cannot enter the inside of the brake caliper through the brake cylinder connection.

Painting instructions

During painting work, all rubber parts must be covered as otherwise the rubber will become brittle and thus be damaged.

**Only brake cylinders approved by the brake
or axle manufacturer may be used**

SK 1000 Disc/ET 120 SK RB 9022 H - SK 1000 ET 120

Torque wrench settings

Use a torque wrench.
The use of impact wrenches
is strictly forbidden.

Wheel nuts:
Hub-centred fixing:
M 22 x 1.5/600 Nm

U-bolts:
(diagonally in three stages)
M 22/650 Nm

Shock absorber:
M 24/400 Nm

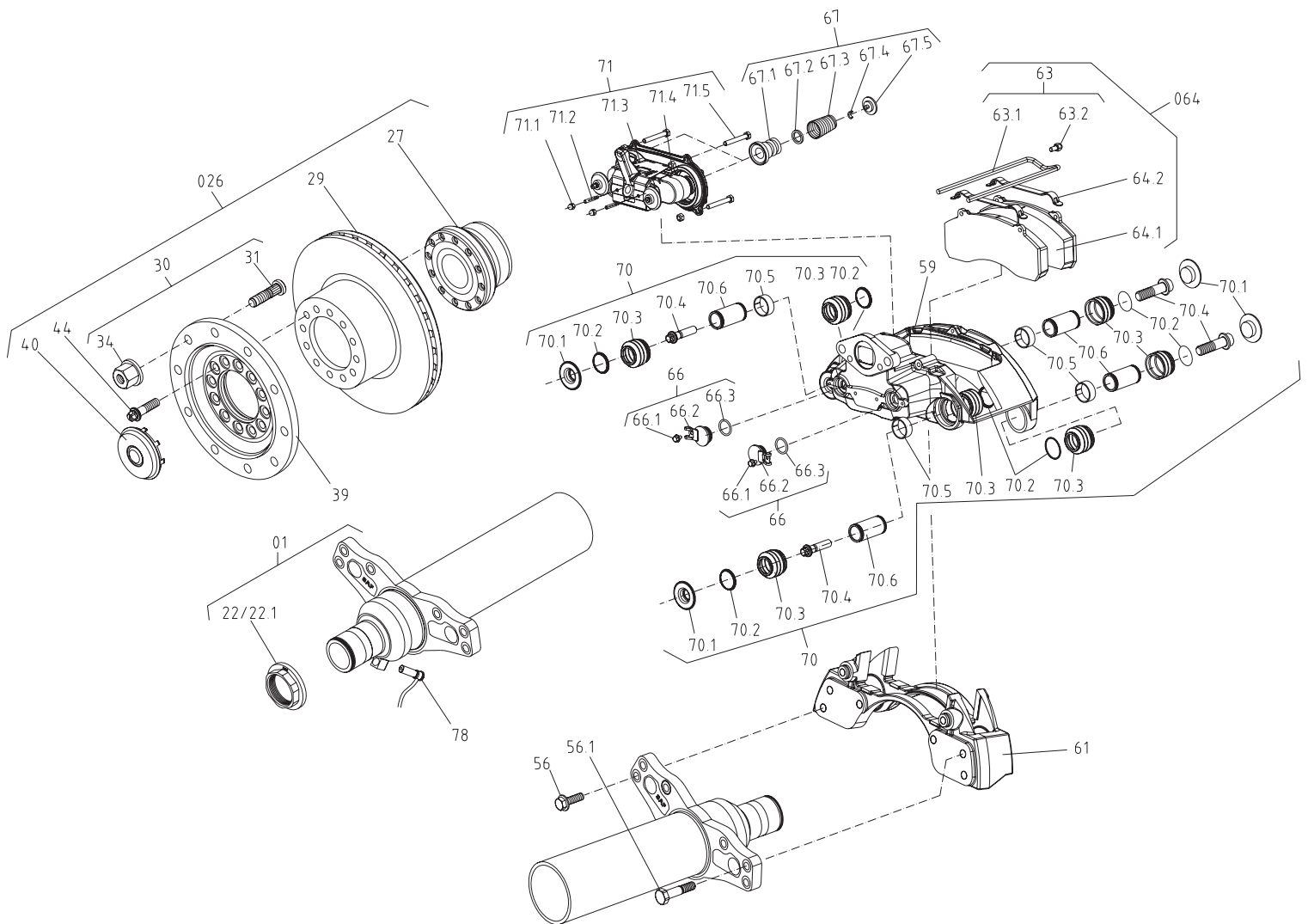

SK 1000 Disc / ET 120 SK RB 9022 H - SK 1000 ET 120

Item	Parts designation	Item	Parts designation
01	Axle beam assembly	59/60	Brake calliper group including items 61 - 70.6
22	Axle nut, RH, W.A.F. 85	59	Brake calliper group, RH
22.1	Axle nut, LH, W.A.F. 85	60	Brake calliper group, LH
56	Hexagon head bolt with collar	61	Brake calliper carrier, RH
56.1	Shoulder bolt	62	Brake calliper carrier, LH
026	Axle end assembly including items 26 - 44	63	Lining retainer set including items 63.1 - 63.2
27	Hub Unit	064	Brake pad set including items 63, 64.1, 64.2
29	Brake disc	66	Cap for adjuster
30	Wheel bolt assembly	67	Tappet with boot
31	Wheel bolt	70	Guide set
34	Wheel nut with pressure plate	71	Tensioning
39	Wheel flange	78	ABS sensor
40	Hub cap with gasket		
44	Torx screw		

Repair kits for SAF disc brake SBH 2243

The following repair kits are available:

Designation	Content (Item No.)
AT brake calliper, RH	incl. pads
AT brake calliper, LH	incl. pads
AT brake calliper, RH	without pads
AT brake calliper, LH	without pads
Brake calliper carrier with guide kit, RH	61
Brake calliper carrier with guide kit, LH	62
Guide set	70
Sealing set for slides	65, 67, 69 and 70.5
Lining fixing hoop (per axle)	064
Tappet with boot	67
Cap for clearance adjuster	66
All kits available only as complete sets!	

When ordering spare parts quote correct axle identification serial no., refer to the axle type plate.



Repairing the brakes

Remove the brake calliper.

Park the vehicle on level, solid ground and chock the wheels to prevent the vehicle from rolling away.

Lift the axle using a jack.

Loosen the wheel nuts and remove the wheel.

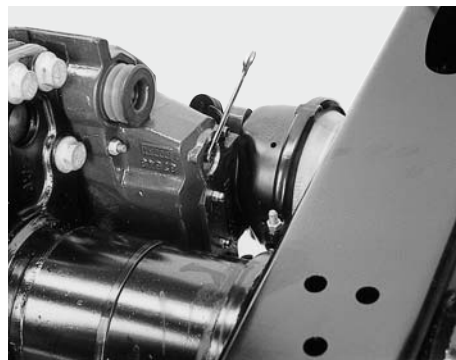
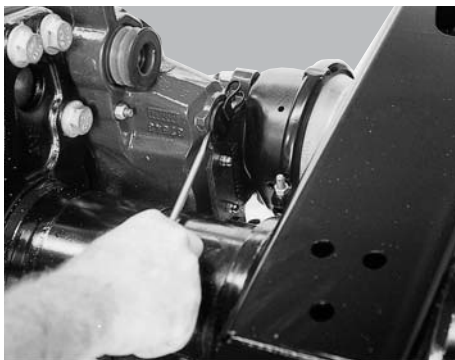

Remove cap.

Turn adjuster either clockwise or anti-clockwise until the stop, so that the linings become free.

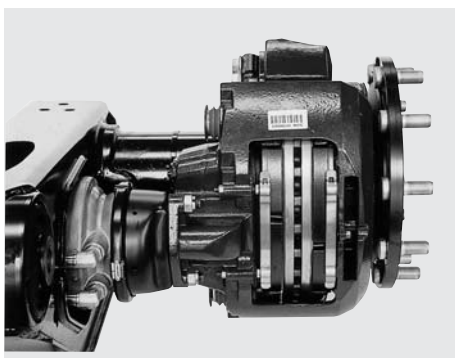

Remove the safety screws from the retainer hoop.

Remove the lining retainer hoop.

Remove the brake linings

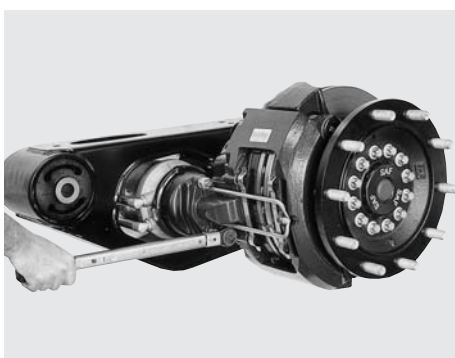

Unbolt the spring pressure or diaphragm cylinder from the brake calliper. Then loosen bolts (6 bolts M 16 x 1.5) and remove the brake calliper.

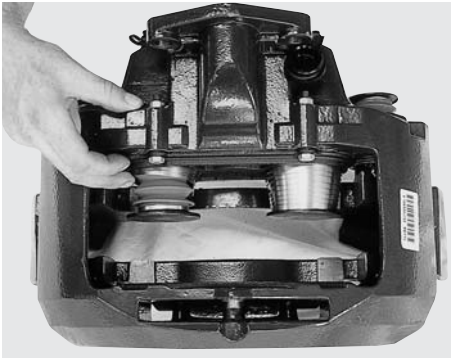

Check the brake calliper for free and easy movement.
Screw out the pressure pin on the adjuster so far until the folding bellows with the compression spring is visible.
Perform a visual inspection of the boots and all seals.
Screw in the tappets again completely.

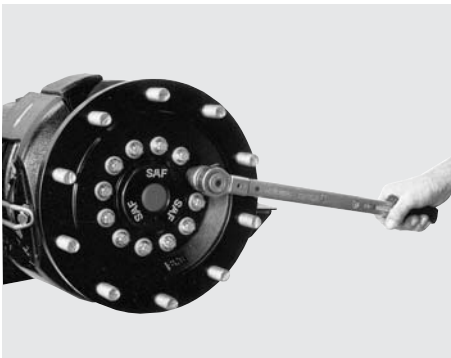

Replacing the brake disc

Screw out the M 18 x 1.5 Hex. screws or the M 18 x 1.5 headed TORX screws and remove the wheel flange.

Note:
Bolts must not be oiled!
(Observe tightening torques)



Press the brake disc off the hub unit with 3 hexagon head bolts M 12 x 30.



Clean contact surfaces before assembly.

Caution!
Seal on axle nut must not be damaged as this would invalidate all warranty claims.

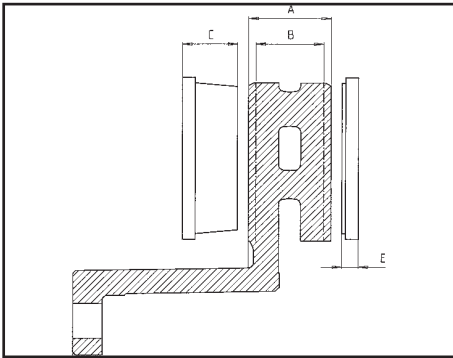

Brake disc

Brake disc diameter

Permissible wear, see table in chapter "Maintenance instructions".

The brake disc may only be cleaned using a dry cleaning agent.

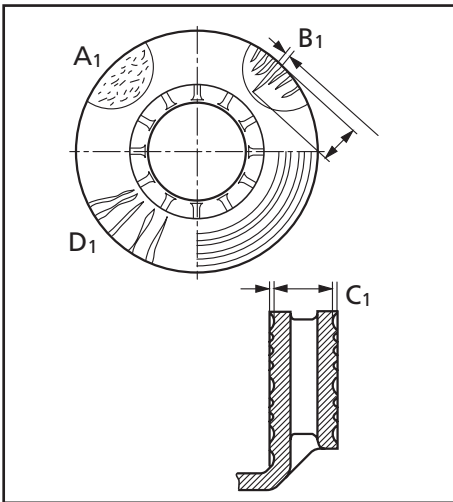

Inspecting the brake disc

Inspect the braking surface of the brake disc carefully for serviceability.

A₁ – Network-like cracks are permissible.

B₁ – Cracks up to max. 1.5 mm (width and depth) running towards the middle of the hub are permissible.

C₁ – Unevenness in the disc surface up to 1.5 mm is permissible.

D₁ – Cracks going right through the disc are not permissible.

Check the brake disc thickness and turn down, if necessary. For safety reasons, the minimum thickness for turning down the brake discs is 39 - 40 mm.

Permissible wear, see table in chapter "Maintenance instructions".

Note:

The compact wheel bearing unit and the brake calliper are not removed for turning down the brake disc.

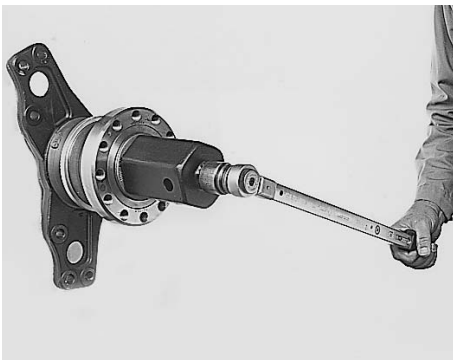

Replacing the Hub Unit

Loosen axle nut and unscrew from stub shaft.

Axle nut wrench, SAF Part No. 2 012 0023 01.

Note:

Axle nut W.A.F. 85

– on left-hand side as seen in direction of forward travel = left-hand thread.

The axle nut with left-hand thread has a milled groove on the outer face for identification.

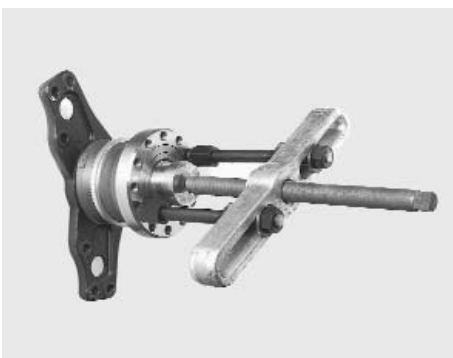

The complete hub unit can be pulled off the stub shaft using a puller, SAF Part No. 4 434 3822 00.

(The hub unit cannot be overhauled and has to be replaced complete with the bolts of the wheel flange).



Installing the Hub Unit

Emery the seating surfaces of the Hub Unit on the stub shaft down to the bare metal and coat with SAF fitting paste (SAF Part No. 4 387 0015 06).

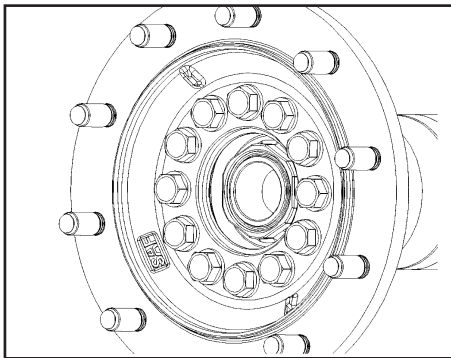

Coat the hub unit bearing surfaces with SAF fitting paste (SAF Part No. 4 387 0015 06) and push onto the stub shaft. Tighten the axle nut to the prescribed torque.

On LH side as seen in direction of travel – LH thread
On RH side as seen in direction of travel – RH thread
Tightening torque 900 Nm. Each hub unit must be rotated smoothly at least twice while tightening the bolts.
Hub nuts with LH thread are marked:
Groove on the face

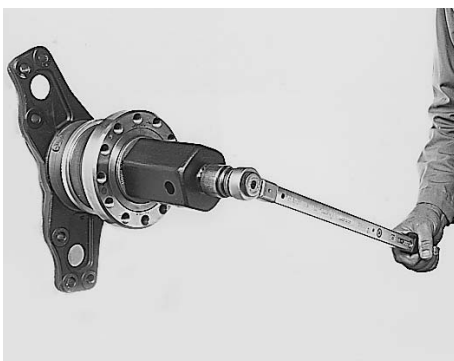

Axle nut W.A.F. 85:
 On left-hand side of vehicle (as seen in direction of forward travel) – left-hand thread.

Identification of axle nut with left-hand thread: Milled groove on outside of hexagonal head.
 Groove on the face.

Tighten the axle nut.
 Axle nut wrench: SAF Part No. 2 012 0023 01

Tightening torque 900 Nm. Each hub unit must be rotated smoothly at least twice while tightening the bolts.
 Special locking of the axle nut is not necessary.



Place the wheel flange onto the hub unit and tighten the new, uncoiled bolts to the prescribed torque.

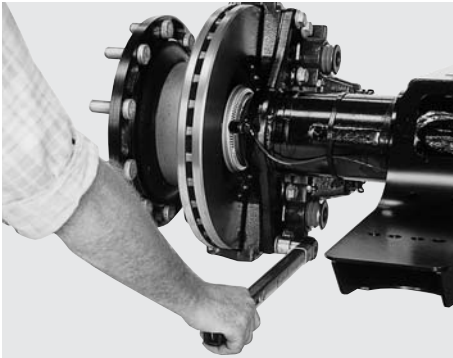

Bolting on the brake calliper

Position the brake calliper and screw in M 16 x 1.5 x 55 collared bolts (tightening torque 290 Nm).

Coat ABS sensor (see arrow) all around with copper paste and install in the sensor holder.

Push in the ABS sensor until it contacts the exciter.

Measure the output voltage at the ABS sensor cable using a voltmeter (approx. 100 mV) while turning the brake disc or wheel flange.

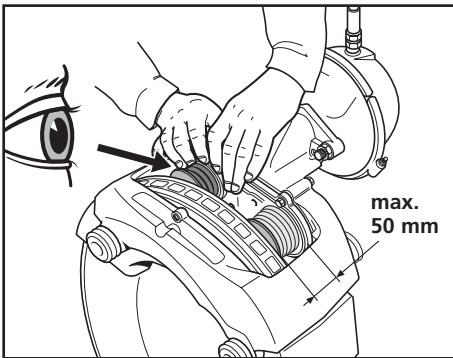

Checking the folding bellows on the pressure pins

The check is to be carried out with the brake linings removed (see page 14).

Turn the adjuster rod using an 8 mm ring spanner until the protection spring is completely visible.

Note!

The pressure pin may only be screwed out to a max. of 50 mm!

Check the protection spring. Finally replace the protection spring and check the folding bellows.

If the folding bellows or protection spring is torn or show signs of other damage then they must be replaced.

Loosen the adjuster rod. **Do not tighten!**

Should work be required (see page 21 - 22)

Fit the brake linings (see page 19)

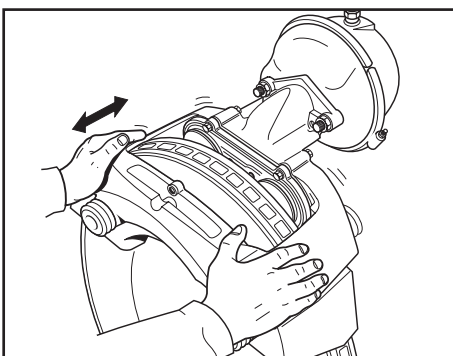

Inspection

Sliding function

Check the sliding movement of the brake calliper over the guide pins.

The brake calliper must be easy to move manually.

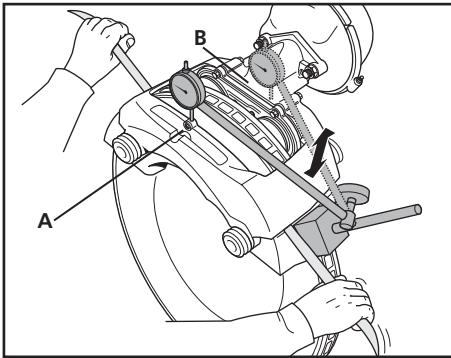

Check for wear in the guide pins. To measure the outer guide pin fit a magnetic holder with dial indicator onto the brake mounting. Set the tip of the indicator on point A, and raise and lower the brake calliper alternatively as shown in the illustration. Finally carry out measurement of the inner guide pin behind the brake disc several times measuring at point B. The maximum play should not exceed **1,0 mm**.

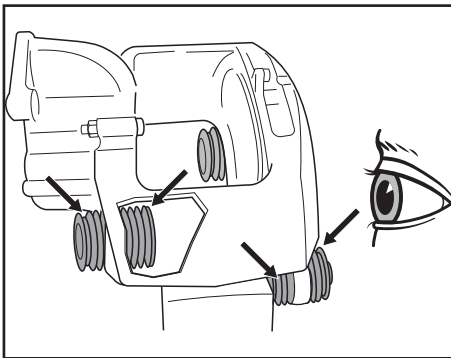

Visible check

Check protection cap and folding bellows guide pins (2 each per guide pin).

the folding bellows and protection cap must be replaced if they show signs of tearing or other damage.

Should work be required see page 22 – 24.

Fit the brake linings (see below).

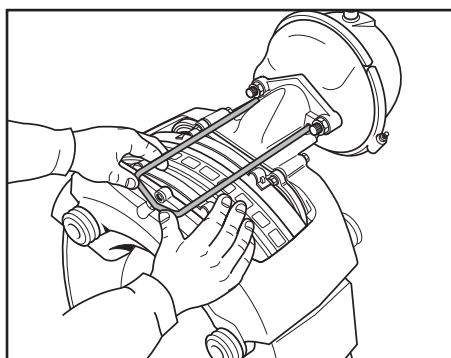

Fitting brake linings

Note!

The brake must be completely adjusted in the back position before fitting the linings.

Clean brake lining cavity.

Push the brake calliper in the direction of the outside of the vehicle and fit the outer brake lining.

Push the brake calliper finally in towards the inside of the vehicle and fit the inner brake linings, (connect wear indicator if applicable)

Fit lining retainer springs.

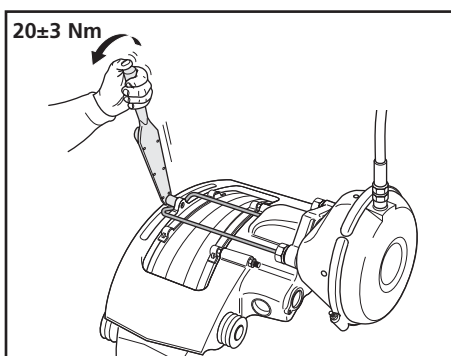

Fitting retainer hoop

Fit the lining retainer hoop in the brake calliper and fix with the safety screws (20 ± 3 Nm).

Carry out basic adjustment (see page 20).

Note!

The wheel hub must be free to be moved manually after actuating the brake (adjust play if necessary).

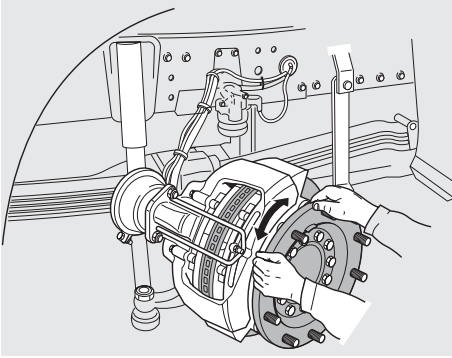

Basic adjustment

Check whether the brake disc can be moved easily.

Using an SAF 8 mm ratchet wrench, turn the adjuster rod until the brake linings come into contact with the brake disc. Then loosen by approx. 1/4 turn to keep a basic play between the brake linings and the brake disc. Check whether the brake disc can be moved easily.

Re-fit the plugs and "O" ring of the adjuster rod (greased).

To achieve the correct play between the brake disc and the brake lining, carry out a series of braking movements in order to let the automatic adjusting mechanism set itself to a finer adjustment setting.



Fit the wheels.

Tighten the wheel nuts using a torque wrench.

Caution!

Tighten the wheel nuts using a torque wrench again after driving 50 km and 150 km!

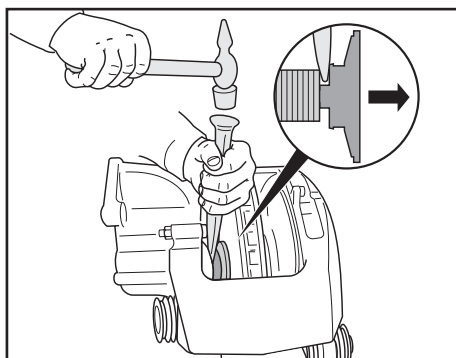

Removal of the folding bellows

Using an 8 mm ring spanner turn the adjuster rod until the pressure pin is approx. 40 mm out of its fully screwed back position. Withdraw the protection screw and cut the bellows in order to gain access to the gap between the pressure pin and the adjusting screw. Remove the pressure pin from the adjusting screw by driving the forked lever into the gap.

Note!
Use issued tools only!

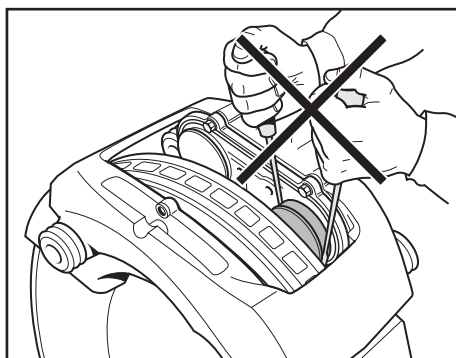

Clean the pressure pin. Remove the protection spring. Turn the adjuster rod until the adjuster screws are screwed fully back.

Note! Do not tighten!

Remove the folding bellows from the cover using an assembly lever.

Note!
Do not damage the adjuster screw and / or the mounting surface of the bellows!
Ensure that no dirt enters through the adjuster screw opening!

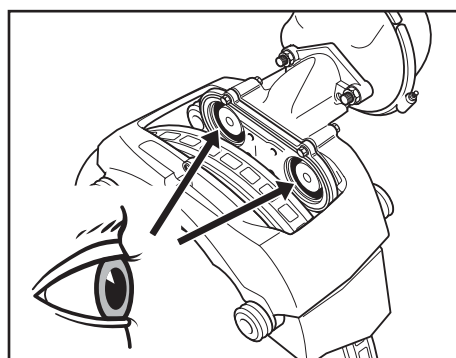
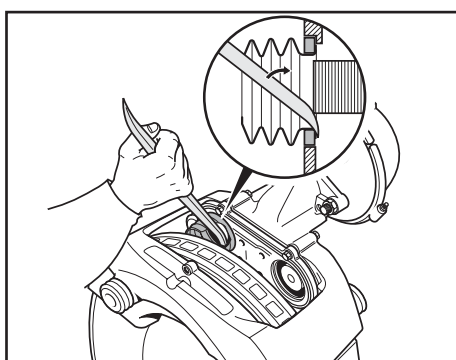

Visible check

Check the mounting surfaces of the bellows on the cover and on the pressure pin. Check the visible part of the tensioning unit for corrosion. Replace if necessary. See page 27. If necessary check the lever for ease of movement.

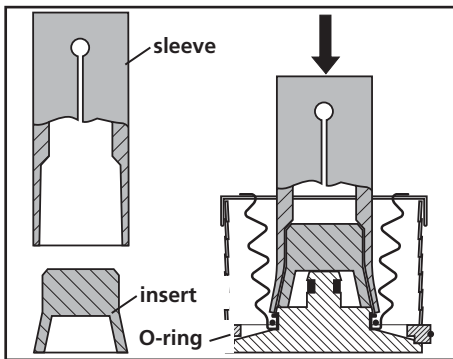

Fitting the folding bellows

Remove the securing ring from the pressure plate. Next, lay the pressure plate on a flat surface with the required tools on top. Place the conical part of the special tool on top. Fit the protection springs with their small ends at the bottom onto their position on top of the special tool. Fit the securing ring into position on the folding bellows. Using the outer part of the special tool, push the folding bellows/securing ring unit into position onto the pressure plate. Remove both parts of the special tool. Re-fit the securing ring. Do not remove the special tool P/N 81926.

Check whether the adjuster screws are fully screwed back.

Note! Do not tighten!

Finally position the special tool P/N 81926 onto its place on the cover.

Press in the bellows unit into the cover using a "G" clamp. Use the special tool P/N 81928 in the adjuster rod hole as support.

Remove the "G" clamp and special tool P/N 81926 and 81928.

The folding bellows and the pressure plate must be pressed fully home.

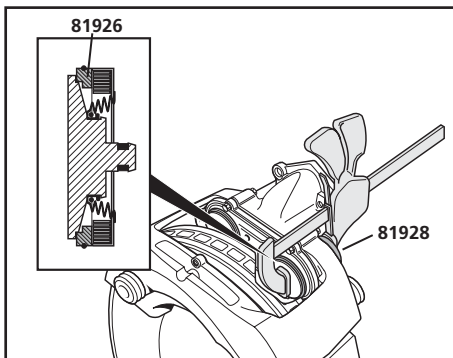

Removal of the guide pins / slides

Secure the disc brakes in a vice.

Remove the 4 cover plates with a hammer and chisel.

The cover plates may not be used again.

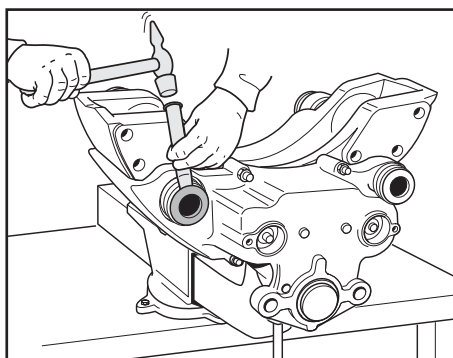
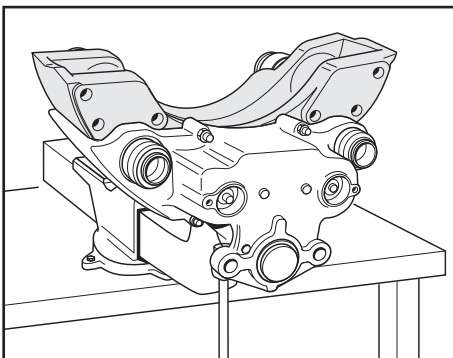

Should any part of the cover plate remain in the guide pin, it can be used with e.g. the help of an inside bearing puller (standard tool).

Remove the 4 screws of the guide pins with the special tool (TORX E 18 nut).

Set the guide pins so far back using a backwards and forwards motion so that the brake calliper can be removed.

Note!

Do not use pipe wrenches or similar tools as the folding bellows' surfaces could be damaged.

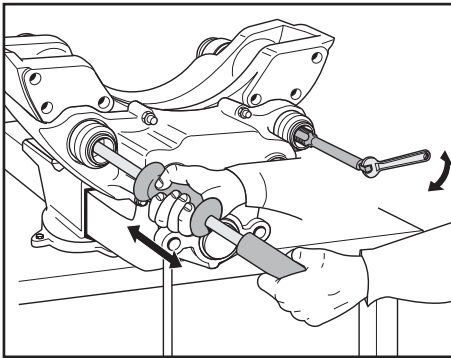

Should the guide pins become seized in the brake mounting, they can be removed by cutting an M16 thread in the guide pin and withdrawing them using an M16 sliding hammer.

Remove the brake mounting from the brake calliper.

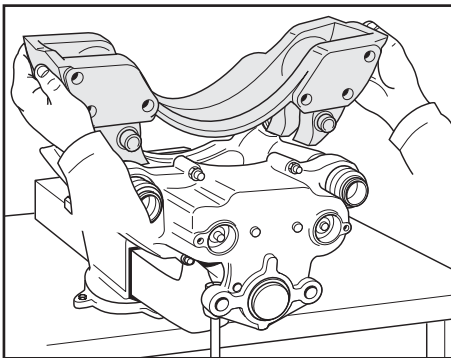

Note!

Danger of injury, hold only on the outsides!

Clean the parts of dirt and dust. Use the recommended dust remover or vacuum cleaner, in no case use compressed air - breathing in of the dust particles can be hazardous to health.

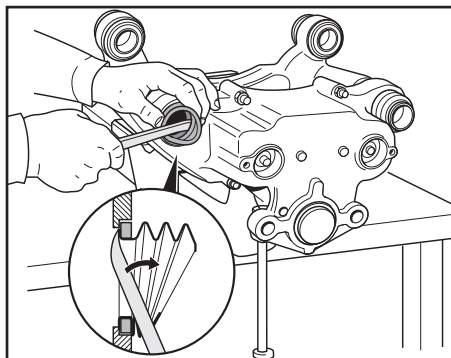

Press out the 4 guide pins from the brake calliper.

Carefully remove the 8 folding bellows using a removal tool.

Note!

The fitting surface must not be damaged!

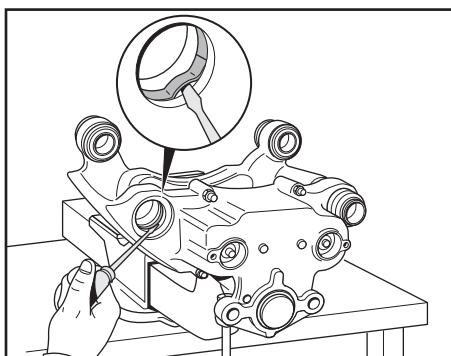

Remove the 4 slotted slides with the help of a small removal tool. Start at the division.

Note!

The fitting surface must not be damaged!

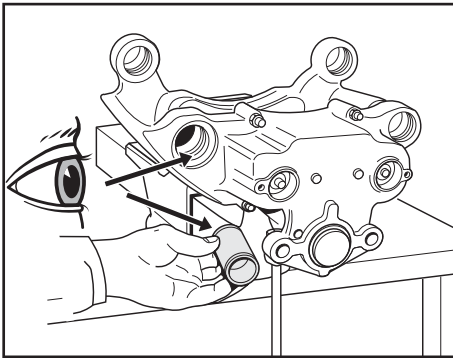

Visible check

The mounting surfaces of the slides and the bellows must be undamaged.

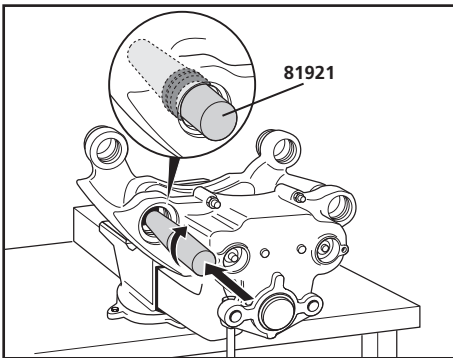

Fitting of the guide pins and the slides.

Fit 4 new slides into the brake calliper.

Push the special tool P/N 81921 into the slide and expand the slide by turning the tool in the slide.

Smear grease (SAF Part No. 4 387 0018 00) thinly onto the slide.

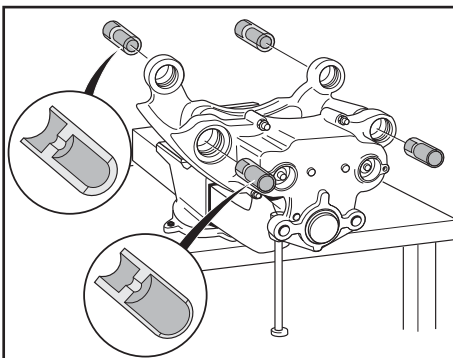

Grease the guide pins with grease (SAF Part No. 4 387 0018 00) and push them into the slides as illustrated.

Note the direction of the guide pins (different hole depths).

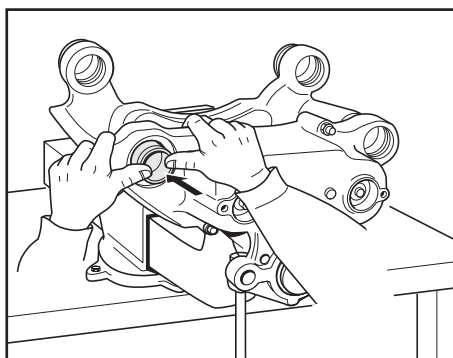

The guide pins should slide easily in the slides so that the brake calliper is easy to move.

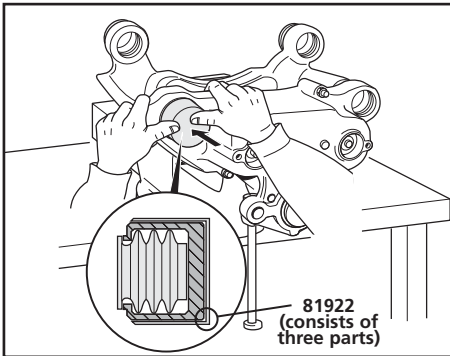

Fit the bellows using the special tool P/N 81922 into the brake calliper.

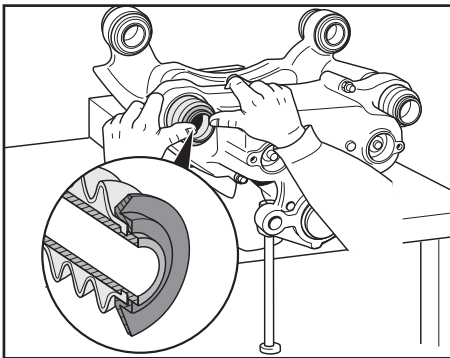

Push the outer part of the folding bellows into the slot of the guide pin and secure with the bellows ring.

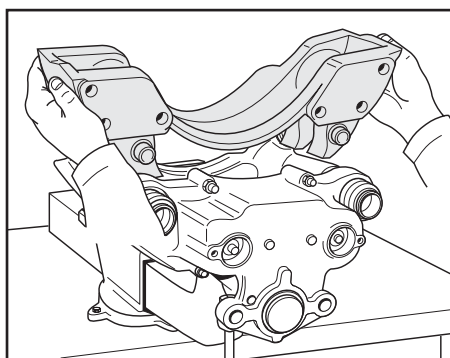

The mounting surfaces - the linings in the brake mounting on the pressure plate; if these are to be used again then they are to be cleaned with a wire brush. **Do not grind or sand.**

Lubricate the fitting surfaces of the guide pins on the brake mounting with copper paste (SAF Part No. 4 387 0020 00).

Push out the guide pins so that they are free for the brake mounting to be assembled.

Set the brake mounting in place on the brake calliper and press in the guide pins so that they slide into the lead in of the brake mounting.

Note!

Danger of injury! Grip only from the outside! Do not damage the bellows!

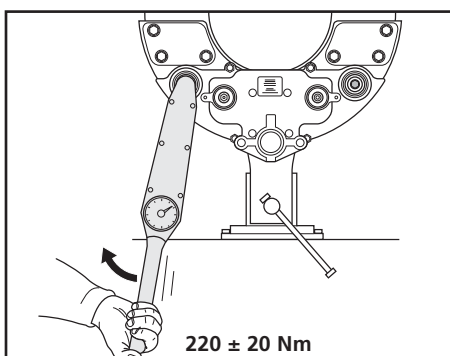

Lubricate the threads of the 4 guide pins with copper paste (SAF Part No. 4 387 0020 00) and screw in.

Tighten to **220 ± 20 Nm** using a torque wrench and the special tool (TORX E 18 nut).

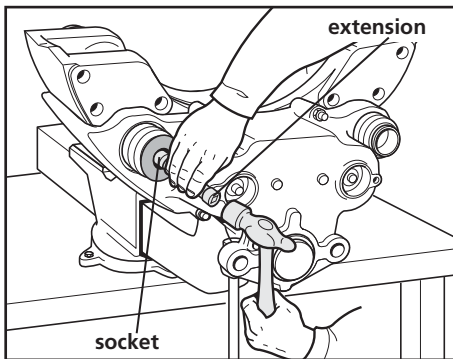

Fit **new** covers to the ends of the guide pins using a **17 mm socket** with extension.

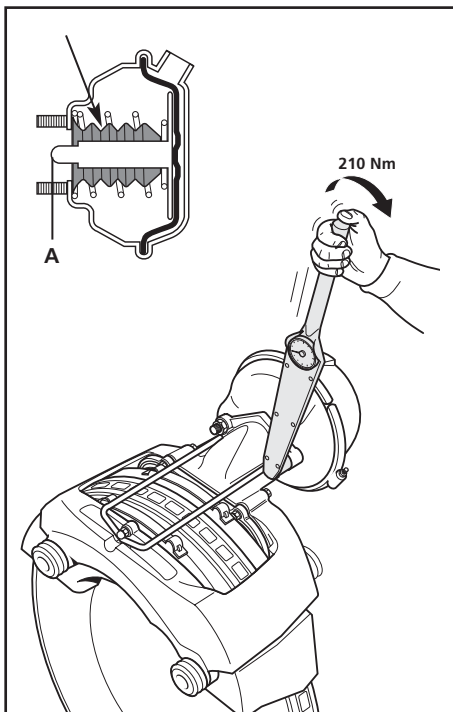

Replacing the brake cylinder

Caution!

Do not repair the brake cylinder due to the "inner sealing". Use only an original replacement cylinder.

Removing the diaphragm cylinder

Unscrew the air connection from the diaphragm cylinder.

Remove the hex. nuts from the diaphragm cylinder.

Remove the diaphragm cylinder.

Installing the diaphragm cylinder

Note:

On the new diaphragm cylinder, the rubber plug in the bore facing downwards must be removed for secondary chamber venting (see arrows).

All other venting bores must remain closed.

Before installing the new diaphragm cylinder, grease the ball in the lever with grease (SAF Part No. 4 387 0018 00)

Caution!

Do not use molybdenum disulphide-saponified grease!

Use only diaphragm cylinders complying with the vehicle manufacturer's specifications.

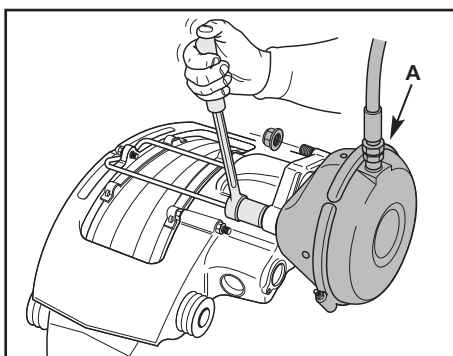

Install the diaphragm cylinder.

Tighten the new hex. nuts of the diaphragm cylinder to 210 Nm.

Connect the brake hose to the diaphragm cylinder, ensuring that the hose is now twisted or kinked and is laid so that chafing is not possible.

Check the air connection for leaks.

Caution!

Carry out a function and efficiency test of the brake system.

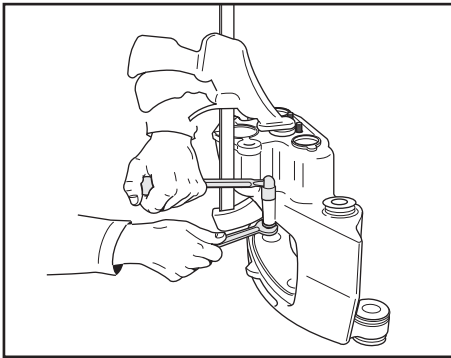

Removing the tensioning unit

The brake calliper must be laid onto a workbench with the fixings of the cylinder facing upwards.

Secure the bearings of the tensioning unit with a "G" clamp before the screws are loosened.

Remove the sealing collar on the adjusting rod.

Remove the two nuts.

Remove the 4 screws of the tensioning unit with their nuts.

Release the clamps and remove the tensioning unit from the brake calliper.

Note!

Do not release the clamp from the tensioning unit - assembled under high spring pressure!

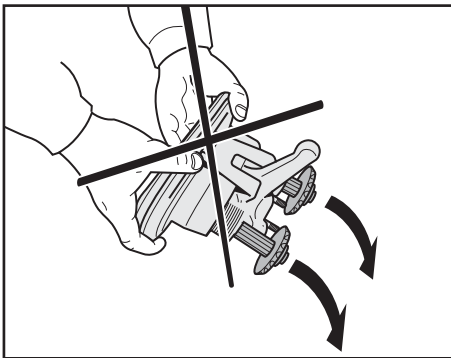

Clean the brake calliper on the inside as well as the sealing surfaces.

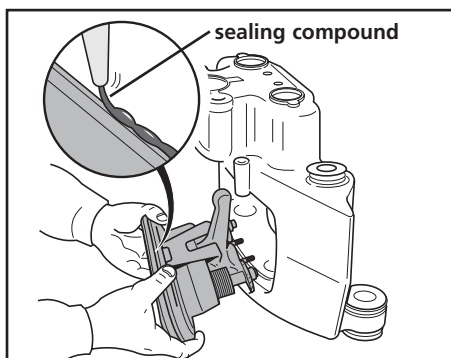

Fitting a new tensioning unit

Note!

Ensure that the new adjusting rods of the new tensioning unit do not slide out of the adjuster screws, as the adjusting mechanism is synchronised from side to side!

If the adjusting rods do slide out see "synchronisation of the adjusting rods" at the end of this chapter.

Lay the brake calliper on a workbench again with the cylinder fixings facing upwards.

Apply sealing compound (SAF Part No. 4 387 0019 00) so that the brake calliper is sealed.

Insert the new tensioning unit into the brake calliper. Ensure that the adjuster rods and both screw pins are located correctly in the brake calliper.

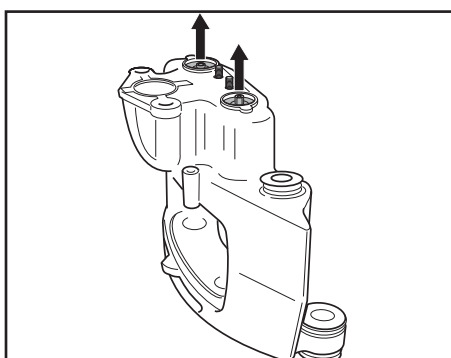

SAF D) Installation instructions

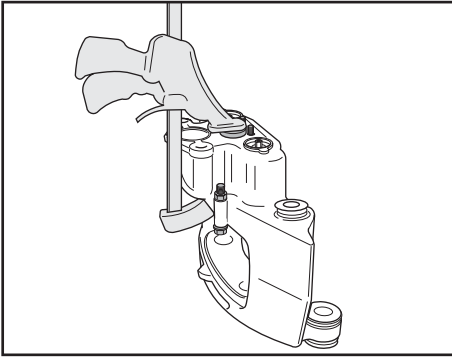

Secure the position of the tensioning unit in the brake calliper with "G" clamps.

Fit the 4 screws and nuts and carefully tighten until they contact the cover and the brake calliper.

Remove the clamps and check that the tensioning unit is located correctly.

Note!

Fit into the brake calliper with the unit un tensioned.

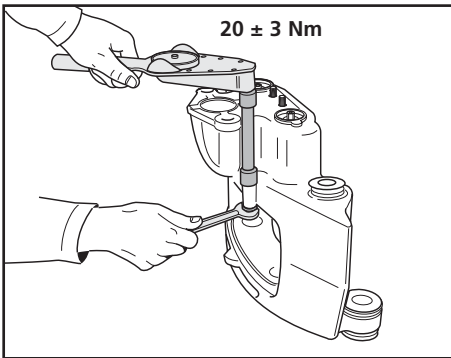

Tightening torque of the screw up to 20 ± 3 Nm.

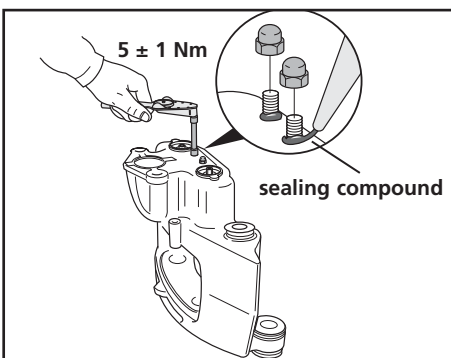

Smear the screw pins thinly with sealing compound (SAF Part No. 4 387 0019 00) and fit the nuts.

Tightening torque 5 ± 1 Nm.

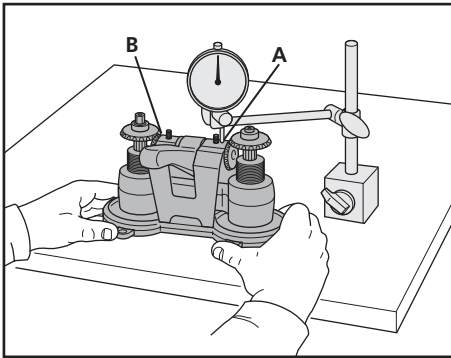

Synchronising the adjustment screws of the tensioning unit

Synchronisation is carried out with the tensioning unit removed.

Check that the pressure plates are fully pushed back against the stops.

Lay the tensioning unit on a surface plate with the pressure plates facing downwards.

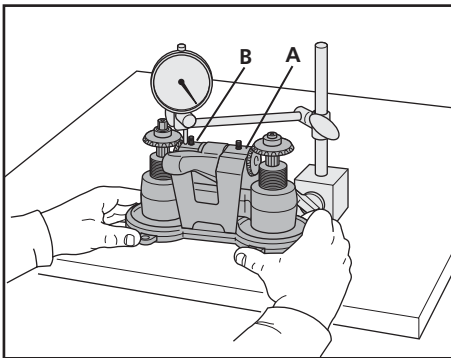

Using a dial indicator with magnetic base, set the tip of the indicator onto the clamp at "A". Set the indicator dial to "0" (zero).

Move the mechanism now until the tip sits on the clamp at "B".

Note!

The dial indicator must remain stationary.

Lift the adjuster rod so that the toothed wheel runs free from the bevel gear. Using the adjuster rod, turn the adjusting screw until the indicator reads "0" (zero).

Return the adjuster rod to its position. If the toothed wheel does not mesh correctly with the bevel gear, lift the adjuster rod and locate it in another position on the adjuster screw. Keep trying **WITHOUT** turning the adjuster rod, until the toothed wheel and the bevel gear mesh together correctly.

Check the measurements again at point "A" and "B" to make sure that they are within 0 ± 0.2 mm of each other.

If the difference is more than 0.2 mm then a new synchronisation must be carried out.

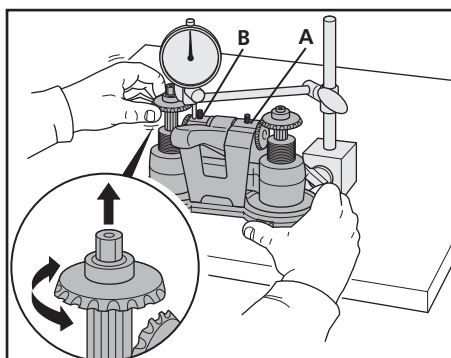

Overview of Hub Unit components



Hub Unit



Hub Unit



Hub cap



Axle nut, RH / LH thread



Wheel flange



Brake disc

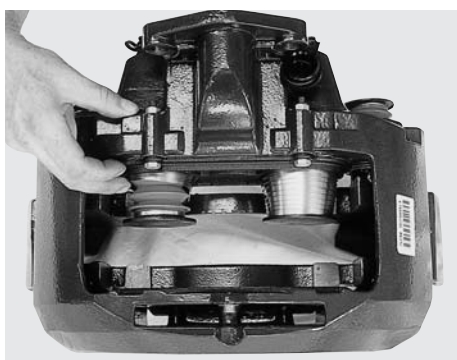

Brake calliper



1. Axle nut wrench WAF 85
SAF Part No. 2 012 0023 01

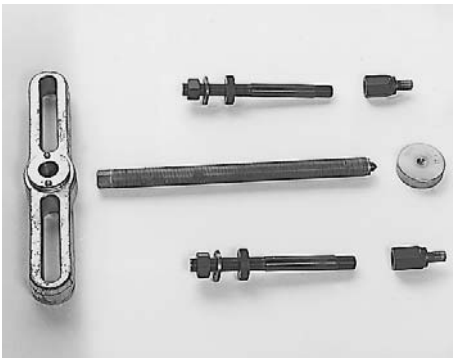

2. Wheel hub puller
SAF Part No. 4 434 3822 00



3. Tool box
SAF Part No. 3 434 6000 00



4. SAF ratchet wrench
SAF Part No. 3 434 3327 00

SAF F) Bolt / Nut torque values

The following tightening torques are only valid if no other values are given in the axle maintenance chart.

Torque wrenches settings, impact wrench not permissible.

Thread	 W.A.F.	Material			
			8,8	10,9	12,9
M 8	W.A.F. 13	25	35	41	
M 8 x 1		27	38	45	
M 10	W.A.F. 17 / 16	49	69	83	
M 10 x 1		52	73	88	
M 12	W.A.F. 19 / 18	86	120	145	
M 12 x 15		90	125	150	
M 14	W.A.F. 22 / 21	135	190	230	
M 14 x 1.5		150	210	250	
M 16	W.A.F. 24	210	300	355	
M 16 x 1.5		225	315	380	
M 18	W.A.F. 27	300	405	485	
M 18 x 1.5		325	460	550	
M 20	W.A.F. 30	410	580	690	
M 20 x 1.5		460	640	770	
M 22	W.A.F. 32	550	780	930	
M 22 x 1.5		610	860	1050	
M 24	W.A.F. 36	710	1000	1200	
M 24 x 2		780	1100	1300	
M 27	W.A.F. 41	1050	1500	1800	
M 27 x 2		1150	1600	1950	
M 30	W.A.F. 46	1450	2000	2400	
M 30 x 2		1600	2250	2700	
M 36 x 2	W.A.F. 55	2450	3450	4150	

Wheel fixing:

Wheels see appropriate axle maintenance chart.

TRILEX wheels	M 18	270 - 300 Nm
	M 20	320 - 350 Nm

Soforthilfe im Pannenfall

NonStopService 24

Support in the case of service

- Im Servicefall wählen Sie bitte **immer** die Rufnummer Ihres **Heimatlandes**.
- In the case of service please **always** dial the number of your **own country**.

Inland home country		Vom Ausland from abroad
03 62 27 23 21	(A)	+43 3 62 27 23 21
0 59 33 07 07	(B)	+32 59 33 07 07
+30 21 09 40 19 80	(BG)	+30 21 09 40 19 80
+386 26 16 58 35	(BIH)	+386 26 16 58 35
0 19 08 64 90	(CH)	+41 19 08 64 90
2 61 10 45 06	(CZ)	+42 02 61 10 45 06
0800 72 37 37 84 / 0 73 33 80 81 58	(D)	00800 72 37 37 84 / +49 73 33 80 81 58
75 72 74 74	(DK)	+45 75 72 74 74
9 02 18 19 92	(E)	+34 9 13 82 68 41
697 91 96	(EST)	+372 697 91 96
03 88 72 06 43	(F)	+3 33 88 72 06 43
0 93 51 31 33	(FIN)	+35 8 93 51 31 33
+41 19 08 64 90	(FL)	+41 19 08 64 90
0 87 02 42 02 37	(GB)	+44 87 02 42 02 37
21 09 40 19 80	(GR)	+30 21 09 40 19 80
06 13 45 17 27	(H)	+36 13 45 17 27
+386 26 16 58 35	(HR)	+386 26 16 58 35
02 66 16 55 74	(I)	+39 02 66 16 55 74
+44 87 02 42 02 37	(IRL)	+44 87 02 42 02 37
+32 59 33 07 07	(L)	+32 59 33 07 07
+372 697 91 96	(LT)	+372 697 91 96
+372 697 91 96	(LV)	+372 697 91 96
+33 3 88 72 06 43	(MC)	+33 3 88 72 06 43
+386 26 16 58 35	(MK)	+386 26 16 58 35
+45 75 72 74 74	(N)	+45 75 72 74 74
+32 59 33 07 07	(NL)	+32 59 33 07 07
+34 9 13 82 68 41	(P)	+34 9 13 82 68 41
06 18 31 98 70	(PL)	+48 6 18 31 98 70
02 12 50 02 60	(RO)	+40 2 12 50 02 60
+39 02 66 16 55 74	(RSM)	+39 02 66 16 55 74
+45 75 72 74 74	(S)	+45 75 72 74 74
+42 02 61 10 45 06	(SK)	+42 02 61 10 45 06
0 26 16 58 35	(SLO)	+386 26 16 58 35
0 21 22 75 13 21	(TR)	+90 21 22 75 13 21
+386 26 16 58 35	(YU)	+386 26 16 58 35

www.saf-axles.com

Otto Sauer Achsenfabrik GmbH · Hauptstraße 26 · D-63856 Bessenbach
Tel +49 (0) 60 95 / 301-0 · Fax +49 (0) 60 95 / 301-259 · www.saf-axles.com

