

CBXA40 AeroBeam™

The Lightest and Toughest Tandem Slider Air Suspension Solution Available for Van and Reefer Trailers Featuring P89 Series Air Disc Brakes

 *Featuring Haldex Calipers and Actuators*



The CBXA40 Aerobeam™ Tandem Slider Air Suspension System

The SAF CBX40 AeroBeam™ is the lightest weight slider air suspension available and features a streamlined design for tough performance and reduced weight. The P89™ air disc brake systems are available as options to increase performance and reduce the maintenance costs of your equipment.

**THE INDUSTRY'S LIGHTEST
WEIGHT SLIDER AIR
SUSPENSION AXLE SYSTEM.**



Optional Upper Body Rails
Roll formed body rails are manufactured from high strength 80,000 lb. yield steel.

Streamlined Design
Streamlined suspension and shock absorber design for a compact suspension package with cast steel durability.

Slider Sub-Frame
80 ksi steel construction with 16 strategically placed reinforcements improves resistance to damage caused by curb strikes, slider repositioning and drag turns.

40,000 - Pound Capacity System

Air Release
is a simple, effective pin-pull system. The air release design is compact, durable, and allows easy manual operation in the event of an air-down situation.

Air Spring
TOFC compatible with a standard pneumatic dump valve.

Swing Align™
The fastest and most convenient axle alignment system in the industry. No replacement parts or disassembly is required. Axle alignment adjustment is made directly by the lead screw, Requires less than 250 ft. lbs. of torque to adjust.

Haldex Spring Brake Actuators
feature the premium LifeSeal+ combination model, the only truly sealed actuator on the market for extended life. Drum brake systems come standard with GoldSeal+ combination actuators which set the industry standard for reliable performance.

Haldex

PosiLok™
minimizes dock walk and suspension squat. Creates a stable and safe loading and unloading operations.

Haldex Single Piston Caliper
is the industry's lightest weight single piston design with a T-shaped, wide thrust plate to ensure even force distribution and sufficient support to the pad back plate.

Multi-functional Pivot Bushing
A robust bushing with its exterior void design limits the twisting movement that could lead to premature bushing and tire wear.

OPTIONAL P89 Series™ AIR DISC BRAKES

Two Model Choices to Meet your Fleet's Specific Needs
The P89 model at a price point that makes sense for fleets of any size. And, the P89 Plus for premium performance. Disc brakes simply provide better performance than drum brakes. They stop shorter for increased safety and reduced maintenance for lower total cost of ownership.

SUPERIOR CORROSION PROTECTION

BLACK ARMOUR™ IS STANDARD WITH AEROBEAM

SAF Holland

ECO-FRIENDLY

Optional P89 Series Air Disc Brakes

**INDUSTRY LEADING
AIR DISC BRAKE
WARRANTY**
See XL-AS11002WC warranty
statement for complete details.

Premium Performance Maintenance Free Design

Featuring the legendary INTEGRAL® rotor/hub and premium sealed bearings for reduced maintenance.

Featuring:

- INTEGRAL® rotor
- Premium brake chambers
- Robust parallel spindle
- 7-Year warranty (see warranty for complete details)
- Long-life sealed bearings
- Haldex calipers and actuators
- Premium spindle nuts

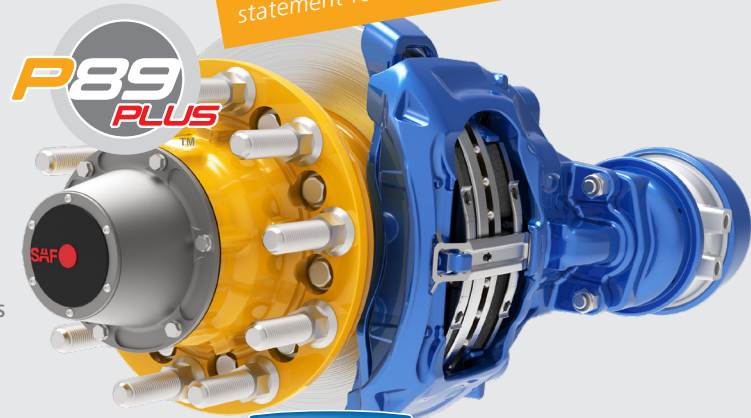

Haldex Featuring Haldex Calipers and Actuators

Proven Design Quality with Genuine Value

All the benefits you expect from the world's leading trailer axle disc brake supplier, at a price point that makes sense for commercial fleets of all sizes.

Featuring:

- Heavy-duty vented rotor
- Premium matched set bearings
- Standard 5-Year warranty (see warranty for complete details)
- Optional P89 PSP7 wheel end package 7-Year warranty (see warranty for complete details)
- Haldex calipers and actuators
- Parallel or taper spindle

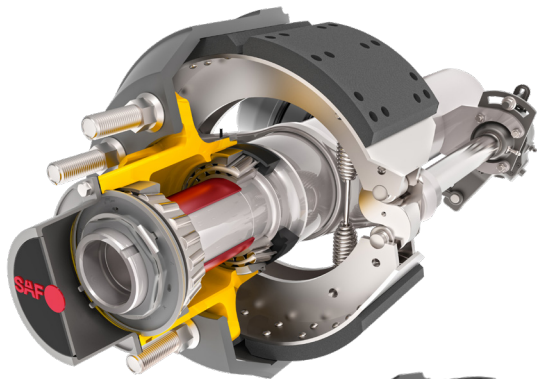

Optional SAF SC7 Wheel End Package

Now available with dressed drum brake configuration, complete your CBX AeroBeam Suspension/Axle system with SAF SC7 wheel ends. Featuring 16½" x 7" extended life brake linings, heavy-duty pre-adjusted hub assembly, optimized bearing spacers, advanced long lasting seals and bearings, and an extended peace of mind 7-year warranty.

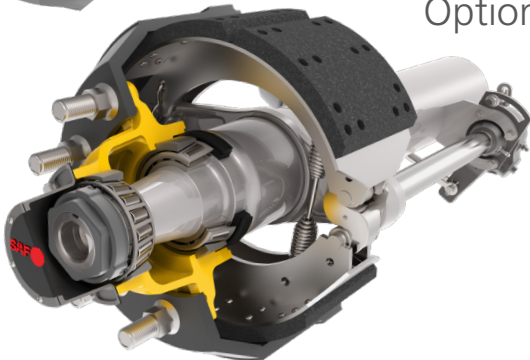

Optional SAF SC5 Wheel End Package

Now available with dressed drum brake configuration, complete your CBX AeroBeam Suspension/Axle system with SAF SC5 wheel ends. Featuring 16½" x 7" extended life brake linings, industry standard hub, long lasting seals and bearings, and a peace of mind 5-year warranty.

Optional Enhanced Tire Pressure Management System



The Tire Pilot™ Plus system is now electronically controlled for enhanced fuel economy and tire life.

Optional Tire Pilot™ Plus not only controls pressure through inflation, but also maintains equal pressure across all wheels and features high pressure relief for overinflated tires. The robust design sets it apart from competitive designs with durable components.

- Automatically responds to small leaks caused by road hazards like nails and metal debris.
- System warning light alerts the driver ONLY when there is a need to immediately seek service.
- Diamond knurled hose connections at both hubcaps and tire valve ends allow installation and replacement without a wrench.
- The stainless steel air hose connections are ported through the sides of the hubcap and are protected between the integrated fins.
- High Pressure Relief feature maintains equal and proper pressure for all tires.
- Tire Pilot Plus can easily be specified on CBX and ULX Series suspensions, or is available as a simple retrofit on existing trailers.
- Can save over \$750 per year per trailer*.



Proper Air Pressure is Critical to Tire Life

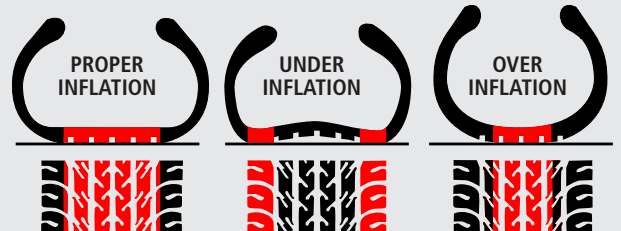

Full Contact
optimizes traction, handling and maximizes tire life.

Outside Contact
accelerates irregular tread wear, increases rolling resistance, and reduces fuel efficiency by up to 2%.

Center Contact
Only reduces tire life and traction. Tire is susceptible to tread damage and punctures.

* TMC RP235 reports the following – Tires underinflated by 10% will wear 9% to 16% faster than properly inflated tires. Underinflated tires add roll resistance that can reduce fuel economy by as much 2%. The average fleet loses \$750 per trailer each year due to improperly inflated tires.

Additional Features

Optional
Auto-PosiLift™
for 1% Savings
in Fuel*

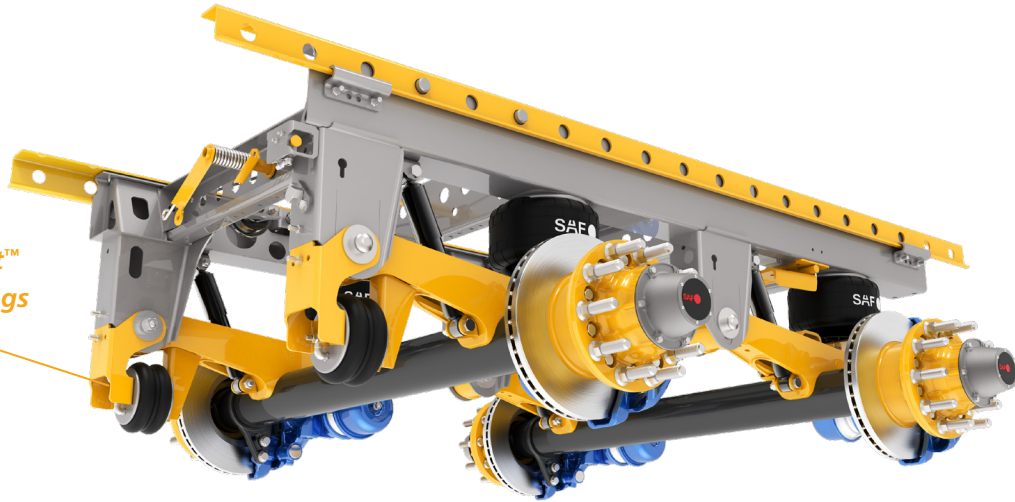

Spec the Auto-PosiLift™ system – tested and proven to provide up to a 1% fuel savings!*

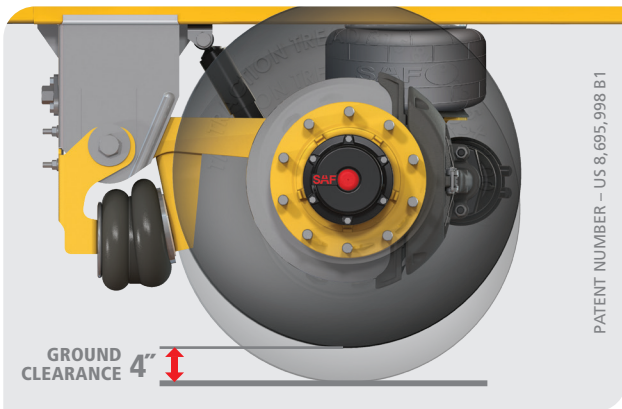

The patented Auto-PosiLift™ feature functions through a programmable ABS with lift axle control to automatically lift the front axle when the system senses that only one axle is necessary to carry the load.

Significant Bottom Line Benefits

- Up to a 1% fuel mileage savings when axle is lifted
- Increased tire life and reduced tire scrub
- No driver interaction required
- Reduction in toll fees
- Increased suspension component life
- Longer wheel end service intervals

* Fuel savings calculated per SAE J1526 Type III. Comparison of a less than loaded trailer with and without an Auto-PosiLift™ system.

SAF drum brake axle is standard equipment

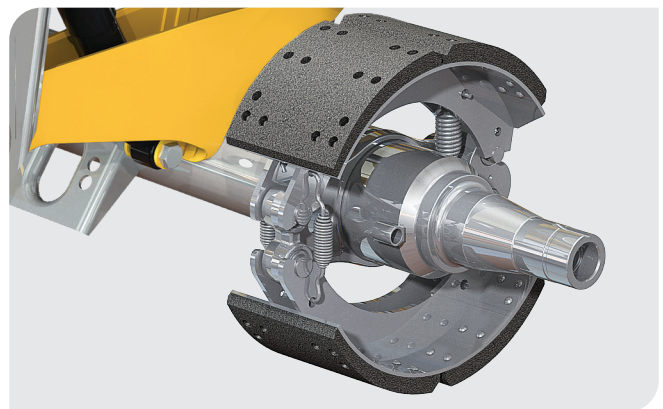

The SAF CBX40 AeroBeam standard configuration features SAF X-Series 5¾" diameter axles with 16½" x 7" extended life brake linings, short cams, and industry standard taper spindles. Optional 16½" x 8⅝" parallel spindles available.

SUSPENSION SYSTEM WEIGHTS**	CBXA40
SAF Undressed Drum Brake Axle (16.5" x 7" braked axle only – no slack adjusters or brake actuators)	1,267 lbs.
SAF Dressed Drum Brake Axle (Includes steel hubs/drums, bearings, oil, slack adjusters and brake actuators)	2,037 lbs.***
SAF P89 Series Air Disc Brake Axle	1,967 lbs.

** Weights shown for a base configuration. 48" wide slider, 16" ride height, 77.5" taper spindle axles, air release, no PosiLok™.

*** Optional lightweight dressed drum brake wheel ends available - 130 lbs. lighter.

CBXA40 AeroBeam™ Specifications

CBXA40 AeroBeam™		
FEATURES	STANDARD	OPTIONS
Ride Heights	16", 16½", 17" & 18"	Upon Request
Slider Width	48"	42" & 54"
Air Release Pin Puller	•	
Patented Qwik Release® Manual Pin Puller		•
Swing Align™	•	
Assembled System	•	
Height Control Valve with Dump	•	
Height Control Valve without Dump		•
Air Springs w/1/4" Ports	•	
PosiLok™ – Anti Dock Walk Device	•	
Auto-PosiLift™		•
Slider Configured to Accommodate 6" Center 1⅜" Body Rails	•	
Slider Configured to Accommodate 4" Center 1⅜" Body Rails		•
Air Tank, Mud Flap & Stinger Brackets		•
Holland Upper Slider Rails		•
Manual Stop Bars		•

DRUM BRAKE AXLE PACKAGE	STANDARD	OPTIONS
Axle Track	77½"	71½", 81½", 83½"*
Spindle	Taper	Parallel
Drum Brake	16½" x 7"	16½" x 8⅝"
Extended Life Linings	SAF Standard 20k	SAF Standard 23k
Tire Inflation Prep: Drilled & Tapped Only	•	
Tire Pilot Plus™		•
Cam Enclosures		•
Dust Shields		•
SAF SC5 Wheel End Package (5-Year System)		•
SAF SC7 Wheel End Package (7-Year System)		•

OPTIONAL P89 SERIES AIR DISC BRAKE AXLE PACKAGE	STANDARD	OPTIONS
Axle Track	77½"	71½", 81½", 83½" *
P89 (5-Year System)	•	
P89 PSP7 (7-Year System)		•
P89 Plus (7-Year System)	•	
Spindle – P89	Parallel	Taper
Spindle – P89 PSP7	Parallel	Taper
Spindle – P89 Plus	Parallel	NA
Calipers – Haldex Single Piston	•	NA
Dust Shields		•
Tire Inflation Prep: Drilled & Tapped Only	•	
Tire Pilot Plus™		•

* Other axle tracks available upon request.

Engineering Your Road to Success

The SAF-HOLLAND® Group is one of the leading international manufacturers of suspension-related assemblies and components for trailers, trucks and buses. Our innovative products increase the efficiency, safety and environmental friendliness of commercial vehicles, contribute to the success of our customers. With around 3,000 employees worldwide, we are at the forefront of shaping the future of the transportation industry.



Trailer Axles and
Suspension Systems



Coupling and Lifting
Technologies



Brake Solutions &
Air Valve Technologies



Suspensions and Components
for Commercial Vehicles



Suspensions for
Trucks and Buses



Trailer
Telematics



Coupling and Lifting
Technologies



Trailer Axles and
Suspensions Systems

safholland.com

SAF-HOLLAND, Inc

Tel 800.876.3929

SAF-HOLLAND Canada Limited

Tel 519.537.3494

Western Canada 604.574.7491

SAF-HOLLAND Mexico

Tel 52.55.5456.8641