

Rebuild/Repair Manual

Yard Spotter Fifth Wheel Top Plates

- FW35TT/XA-351-TT Series
- FW67/XA-351-UBT Elevating Series





Contents Page

Introduction 3

Notes, Cautions and Warnings 3

Section 1 – General Safety Instructions 4

Section 2 – Model Identification 5

Exploded View 6

Parts List 7

Section 3 – Top Plate Removal 8

Section 4 – Yoke Installation 9

Section 5 – Lock Installation 10

Contents Page

Section 6 – Cam Plate Installation 11

Section 7 – Secondary Lock Installation 13

Section 8 – Cam Spring Installation 14

Section 9 – Air Cylinder Installation 15

Section 10 – Upshock Cushions, Pocket Inserts
and Brackets Inspection 16

Section 11 – Top Plate Installation 18

Section 12 – Operation Check 19

Introduction

This manual provides the information necessary to properly rebuild FW35TT/XA-351-TT Series top plates, and FW67/XA-351-UBT elevating fifth wheel top plates.

Read this manual before using or servicing this product. Updates to this manual, which are published as necessary, are available on the internet at www.safholland.us.

When replacement parts are necessary, SAF-HOLLAND® requires the use of only SAF-HOLLAND Original Parts. A list of technical support locations that supply SAF-HOLLAND Original Parts and an Aftermarket Parts Catalog are available on the internet at www.safholland.us or contact Customer Service at 888-396-6501.

Notes, Cautions, and Warnings

Before starting work on any SAF-HOLLAND fifth wheel assembly, read and understand all the safety procedures presented in this manual. This manual contains the terms "NOTE", "IMPORTANT", "CAUTION", and "WARNING" followed by important product information. These terms are defined as follows:

NOTE: Includes additional information to enable accurate and easy performance of procedures.

IMPORTANT: Includes additional information that, if not followed, could lead to hindered product performance.

CAUTION

Used without the safety alert symbol, indicates a potentially hazardous situation which, if not avoided, could result in property damage.

⚠ CAUTION

Indicates a potentially hazardous situation which, if not avoided, could result in minor or moderate injury.

⚠ WARNING

Indicates a potentially hazardous situation which, if not avoided, could result in death or serious injury.

1. General Safety Instructions

- Read and observe all Warning and Caution hazard alert messages. The alerts provide information that can help prevent serious personal injury, damage to components, or both.

⚠ WARNING Failure to follow the instructions and safety precautions in this manual could result in improper servicing or operation leading to component failure which, if not avoided, could result in death or serious injury.

- All repair and maintenance should be performed by a properly trained technician using proper/special tools, and safe procedures.

NOTE: In the United States, workshop safety requirements are defined by federal and/or state Occupational Safety and Health Act (OSHA). Equivalent laws could exist in other countries. This manual is written based on the assumption that OSHA or other applicable employee safety regulations are followed by the location where work is performed.

NOTE: Before rebuilding the HOLLAND® Fifth Wheel review the model number on the serial tag. This rebuild procedure applies only to the FW35TT/XA-351-TT and FW67/XA-351-UBT elevating fifth wheel top plates.

IMPORTANT: All maintenance **MUST** be performed while the tractor is uncoupled from the trailer.

IMPORTANT: These instructions apply to the proper rebuild of FW35TT/XA-351-TT Series and FW67/XA-351-UBT elevating fifth wheel top plates only. There are other important checks, inspections, and procedures not listed here that are necessary, prudent, and/or required by law.

- For proper installation procedures, refer to Installation Manual XL-FW10008BM-en-US available on the internet at www.safholland.us.

IMPORTANT: Prior to operation of the fifth wheel, verify that the fifth wheel has been properly installed on the vehicle.

⚠ WARNING Failure to properly repair and install the fifth wheel could adversely affect performance resulting in tractor trailer separation which, if not avoided, could result in death or serious injury.

2. Model Identification

This manual contains the installation procedures for SAF-HOLLAND rebuild kits RK-351-TT and RK-351-UBT. Prior to rebuilding, verify the correct rebuild kit by identifying the fifth wheel model number, which can be found on the fifth wheel serial tag.

The fifth wheel serial tag is located on the side of the fifth wheel top plate, above the bracket pin location or near the pickup ramps (**Figure 1**). The fifth wheel model number and serial number are listed on the tag as illustrated (**Figure 2**).

For **FW35TT/XA-351-TT** Series fifth wheels (**Figure 3**), use the RK-351-TT Rebuild Kit.

For **FW67/XA-351-UBT** Series fifth wheels (**Figure 4**), use the RK-351-UBT Rebuild Kit.

Figure 1

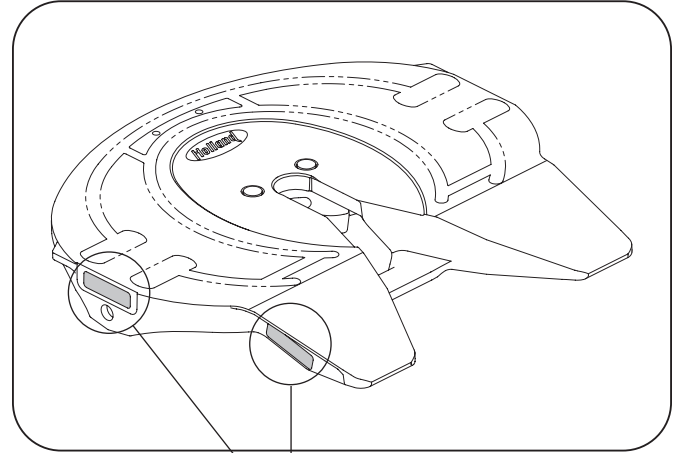

Figure 2

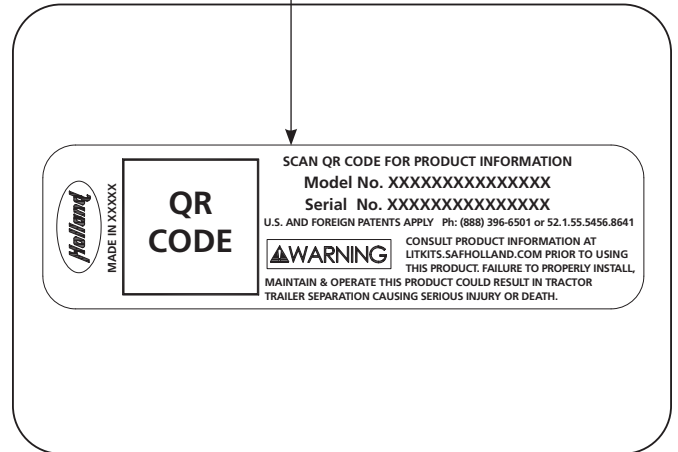

Figure 3

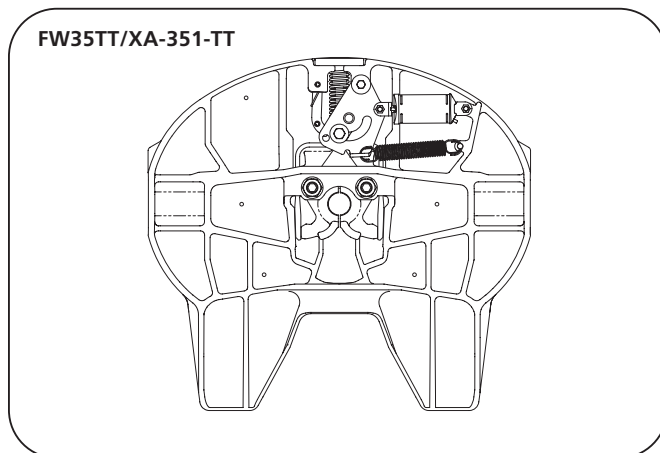
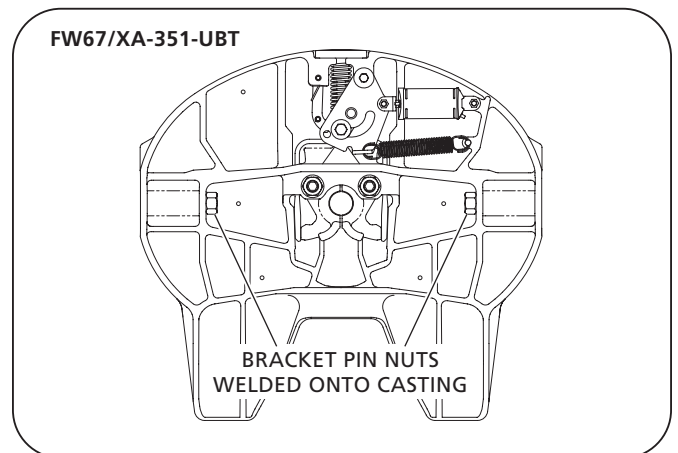
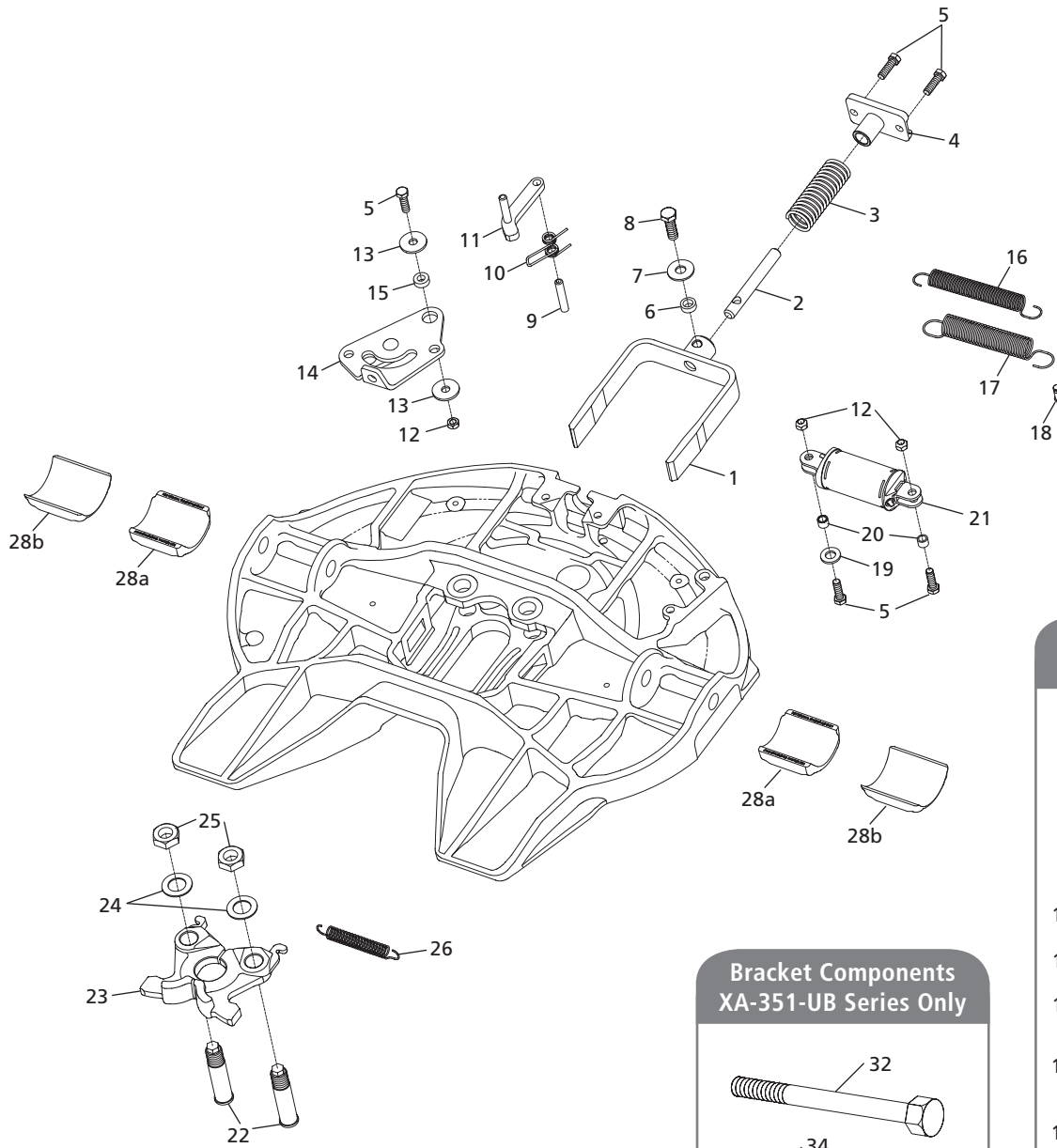

Figure 4





RK-12196

5
6
7
8
12
13
15
18
16
17
19
20
14

**Bracket Components
XA-351-UB Series Only**

32
34
33

Two (2) of each required

**RK-PKT-5
Pocket Inserts**

28a
28b
35

**RK-12058
XA-351-TT Series Only**

29
30
31

Two (2) of each required

RK-12197

26
25
24
22
23

Service Tools

36
37

RK-351-TT AND RK-351-UBT PARTS LIST			
ITEM	DESCRIPTION	PART NUMBER	QTY
1	Yoke	XA-12044-P	1
2	Yoke Shaft	XA-12038-ST	1
3	Yoke Spring	XB-1505-P	1
4	Spring Block	XD-12028-P	1
5	Hex Head Cap Screw, M12 x 1.75 x 40 mm	XB-HCS-M12-40-Z	5
6	Roller, 5/8" I.D.	XA-1507-1-P	1
7	Washer, 5/8" I.D. x 1-3/4" O.D.	XB-460	1
8	Hex Head Cap Screw, M16 x 2 x 50 mm (Yoke/Cam Connection)	XB-12049	1
9	Roll Pin, Ø1/2" x 2-3/4"	XB-21-S-500-2750P	1
10	Torsion Spring	XB-2149-P	1
11	Secondary Lock	XA-3542-T-P	1
12	Lock Nut, M12 x 1.75	XB-HLN-M12-Z	3
13	Washer, 14 mm I.D. x 45 mm O.D.	XB-76004	2
14	Cam Plate Assembly	XA-12036-A	1
15	Roller, 1/2" I.D.	XA-1029-P	1
16	Cam Spring, Inner	XB-10087-P	1
17	Cam Spring, Outer	XB-10088-P	1
18	Clevis Pin	XA-12039-P	1
19	Washer, 5/8" I.D. x 1-1/4" O.D.	XB-06180	1
20	Bushing	XA-10810-P	2
21	Air Cylinder	XA-12057	1
22	Lock Pin	XA-12046-P	2
23	Lock Set	XA-08332-1-P	1
24	Lock Pin Washer, 1-1/8" I.D. x 2" O.D.	XB-10249	2
25	Lock Nut, M27 x 3	XB-12027	2
26	Lock Spring	XB-07628-P	1
27	Never-Seez® (Not Shown)	XB-02967	1
28a	Pocket Insert (included with RK-351-TT kit)	XD-12026-P	2
28b	Pocket Insert (included with RK-351-UBT kit)	XD-08908-P0	2

RK-12197 PARTS LIST			
ITEM	DESCRIPTION	PART NUMBER	QTY
22	Lock Pin	XA-12046-P	2
23	Lock Set	XA-08332-1-P	1
24	Lock Pin Washer, 1-1/8" I.D. x 2" O.D.	XB-10249	2
25	Lock Nut, M27 x 3	XB-12027	2
26	Lock Spring	XB-07628-P	1
27	Never-Seez® (Not Shown)	XB-02967	1

Note: Kits available from a local SAF-HOLLAND Distributor.

RK-12196 PARTS LIST			
ITEM	DESCRIPTION	PART NUMBER	QTY
2	Yoke Shaft	XA-12038-ST	1
5	Hex Head Cap Screw, M12 x 1.75 x 40 mm	XB-HCS-M12-40-Z	3
6	Roller, 5/8" I.D.	XA-1507-1-P	1
7	Washer, 5/8" I.D. x 1-3/4" O.D.	XB-460	1
8	Hex Head Cap Screw, M16 x 2 x 50 mm (Yoke/Cam Connection)	XB-12049	1
12	Lock Nut, M12 x 1.75	XB-HLN-M12-Z	3
13	Washer, 14 mm I.D. x 45 mm O.D.	XB-76004	2
14	Cam Plate Assembly	XA-12036-A	1
15	Roller, 1/2" I.D.	XA-1029-P	1
16	Cam Spring, Inner	XB-10087-P	1
17	Cam Spring, Outer	XB-10088-P	1
18	Clevis Pin	XA-12039-P	1
19	Washer, 5/8" I.D. x 1-1/4" O.D.	XB-06180	1
20	Bushing	XA-10810-P	1

RK-12058 PARTS LIST (XA-351-TT SERIES ONLY)			
ITEM	DESCRIPTION	PART NUMBER	QTY
29	Clinch Pin	XB-12043	2
30	Bracket Pin	XA-12037-P	2
31	Rubber Bushing	XB-0011	2

BRACKET COMPONENTS (XA-351-UBT SERIES ONLY)			
ITEM	DESCRIPTION	PART NUMBER	QTY
32	Hex Head Cap Screw, 1-1/8"-7 x 7"	XB-BR-118-C-7	2
33	Lock Washer, 1-1/8"	XB-E-536	2
34	Rubber Bushing	XB-1604-5	2

RK-PKT-5 PARTS LIST (XA-351-TT SERIES ONLY)			
ITEM	DESCRIPTION	PART NUMBER	QTY
28a	Pocket Insert	XD-12026-P	2
35	Double Face Tape	XB-09422	4

RK-PKT-2 PARTS LIST (XA-351-UBT SERIES ONLY)			
ITEM	DESCRIPTION	PART NUMBER	QTY
28b	Pocket Insert	XD-08908-P0	2
35	Double Face Tape	XB-09422	4

SERVICE TOOLS			
ITEM	DESCRIPTION	PART NUMBER	QTY
36	Kingpin Gauge	TF-0110	1
37	Kingpin Lock Tester	TF-TLN-5001	1

3. Top Plate Removal

IMPORTANT: The FW35TT/XA-351-TT Series fifth wheel assembly has replaceable pocket inserts installed between the fifth wheel top plate and mounting base. When removing the top plate, the pocket inserts will either remain inside of the top plate pockets, on top of the mounting bracket caps, or may fall out.

CAUTION Failure to prevent pocket inserts from falling out of the top plate could cause a potentially hazardous situation which, if not avoided, could result in minor or moderate injury.

1. Remove the clinch pins from the bracket pins on both sides of the fifth wheel top plate (**Figure 5**).
2. Using a pry bar, pull the bracket pins out on both sides of the fifth wheel top plate (**Figure 5**).
3. Disconnect the air lines from the air cylinder under the fifth wheel top plate. If the fifth wheel is equipped with auto-lube, disconnect the grease lines.
4. Using a lifting device capable of lifting 500 lbs. (227 kg), remove the top plate from the mounting base. Place the fifth wheel upside down on a flat, clean working area.

NOTE: Follow the instructions published by the lifting device manufacturer for proper operation of the lifting device.

5. Completely remove all components from the fifth wheel and discard.

IMPORTANT: DO NOT reuse old parts that were removed during disassembly.

CAUTION Do not hit steel parts with a steel hammer as parts could break, sending steel fragments flying in any direction creating a hazard which, if not avoided, may result in minor to moderate injury.

6. Thoroughly steam clean the top plate.
7. Inspect the fifth wheel top plate for cracks, damage, distortion, and loose lock pin holes. Fifth wheels with cracks, damage, distortion or loose lock pin holes **MUST** be replaced.

Figure 5

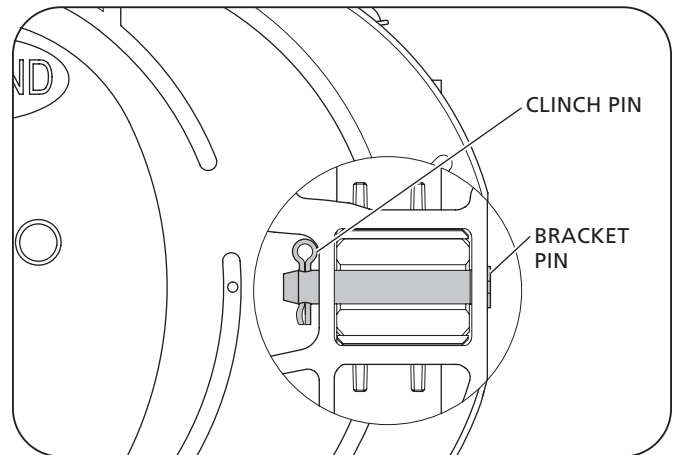

WARNING Failure to replace a cracked, damaged or distorted top plate could result in improper fifth wheel operation and trailer separation which, if not avoided, could result in death or serious injury.

4. Yoke Installation

1. Lubricate tips of the yoke with a water-resistant lithium-based grease (**Figure 6**).
2. With the fifth wheel top plate upside down and the threaded hole of the yoke facing up, slide the yoke into the top plate casting (**Figure 6**).
3. Lubricate the inside tube of the spring block with a water-resistant lithium-based grease (**Figure 7**).
4. Set the spring block into place, ensuring the angled end of the spring block is facing toward the top face of the top plate casting (**Figure 7**). Start two (2) M12 x 1.75 x 40 mm hex head cap screws to hold the spring block in position.
5. Install the yoke spring over the spring block tube, as illustrated in **Figure 8**.
6. Finish securing the spring block by tightening the hex head cap screws, alternating back and forth, until each is torqued to 80 ft-lb. (108 N•m) (**Figure 8**).
7. Slide the yoke shaft, through the spring block and yoke spring, into the yoke. Align the recessed hole in the yoke shaft with the threaded hole in the yoke (**Figure 8**).

Figure 6

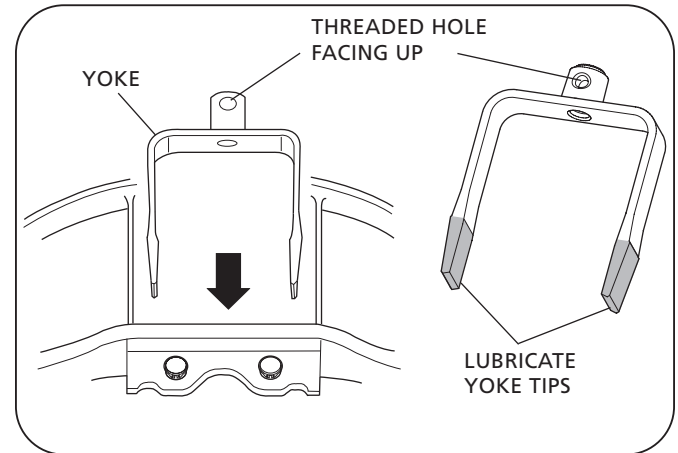

Figure 7

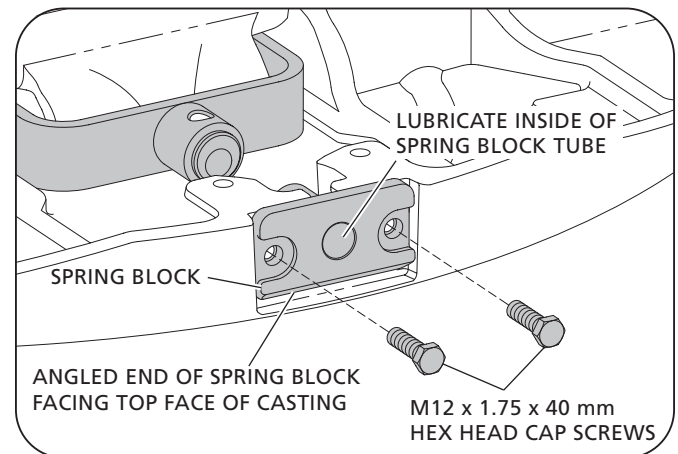
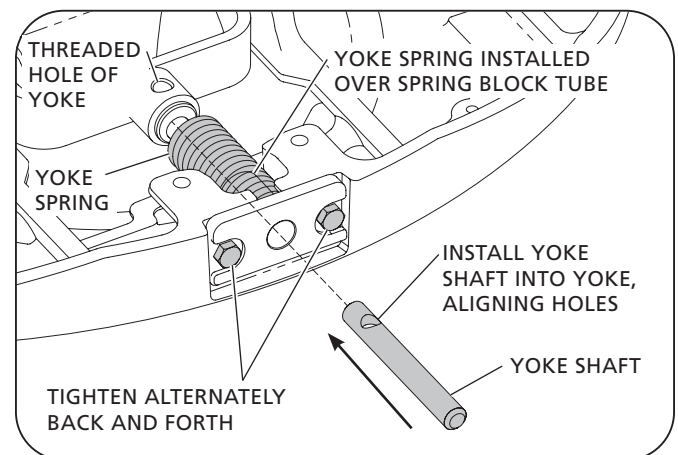

Figure 8



5. Lock Installation

1. Lubricate the lock pin holes of the lock jaws with Never-Seez (provided with the kit) (**Figure 9**).

IMPORTANT: Only use Never-Seez when lubricating the lock pin holes of lock jaws. DO NOT use a substitute lubricant.

2. Attach the lock spring onto the lock jaws and force them closed, extending the lock spring (**Figure 9**).
3. Slide the closed lock jaws into the top plate casting, lining up the lock pin holes of the lock jaws with the lock pin holes in the casting. Be sure to position the lock jaws with the kingpin guides facing away from the casting (**Figure 9**). The yoke will hold the locks closed once they are in place.
4. With the lock jaws properly positioned in the casting, drive the lock pins up from underneath the casting, through the aligned lock pin holes of the casting and lock jaws until the heads are flush with the casting (**Figure 10**).

NOTE: The spring on the lock jaws may pull the lock pin holes out of alignment when installing the lock pins. If needed, insert a bracket pin through the lock pin holes from the top to align the lock pin holes while installing the lock pin from the bottom.

5. Install the lock pin washers and M27 x 3 lock nuts onto the lock pins to secure (**Figure 10**). Torque to 140-160 ft-lb (190 to 217 N•m). Use the hex feature on the end of the lock pins to hold the lock pin stationary while torquing the lock nut.

Figure 9

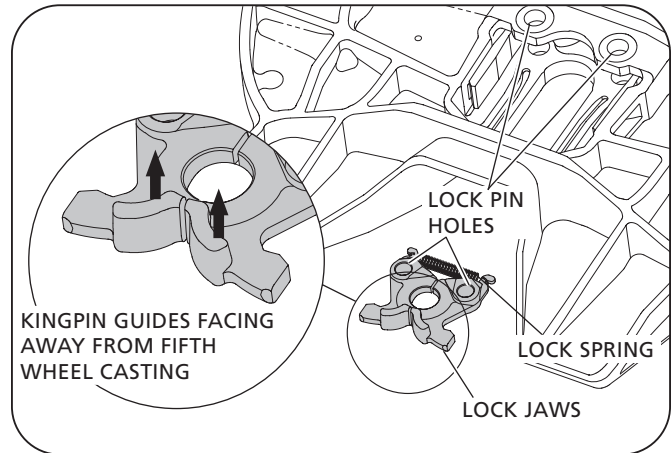
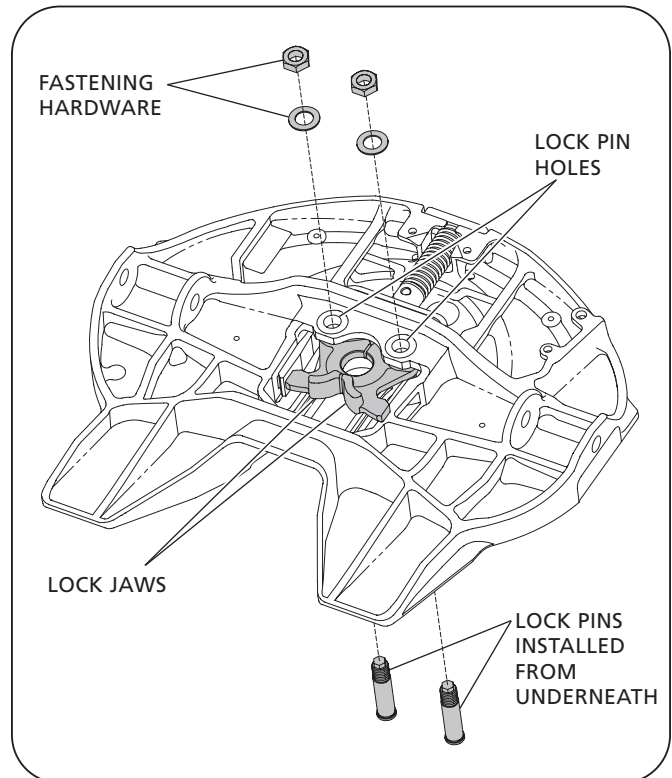

Figure 10



6. Cam Plate Installation

IMPORTANT: For the steps outlined in Section 6, SAF-HOLLAND recommends the use of hand tools ONLY, instead of air tools.

1. Lubricate the cam plate pivot hole and track with a water-resistant lithium-based grease (**Figure 11**).
2. Position the cam plate pivot hole over the casting lug hole, as shown (**Figure 12**).
3. Place the first 14 mm I.D. x 45 mm O.D. washer between the cam plate and casting lug hole with the rounded side of the washer facing the cam plate (**Figure 12**).

NOTE: When installing washers, the rounded edge of the washers must ALWAYS face the cam plate.

4. Install the 1/2" I.D. roller into the cam plate and place the second 14 mm I.D. x 45 mm O.D. washer on top of the roller with the rounded side of the washer facing the cam plate (**Figure 13**).
5. Install the M12 x 1.75 x 40 mm hex head cap screw through the washers, roller and casting lug hole (**Figure 13**).
6. Secure the hex head cap screw with a M12 x 1.75 lock nut and torque to 80 ft-lb. (108 N•m). Check for free movement of the cam plate (**Figure 13**).

Figure 11

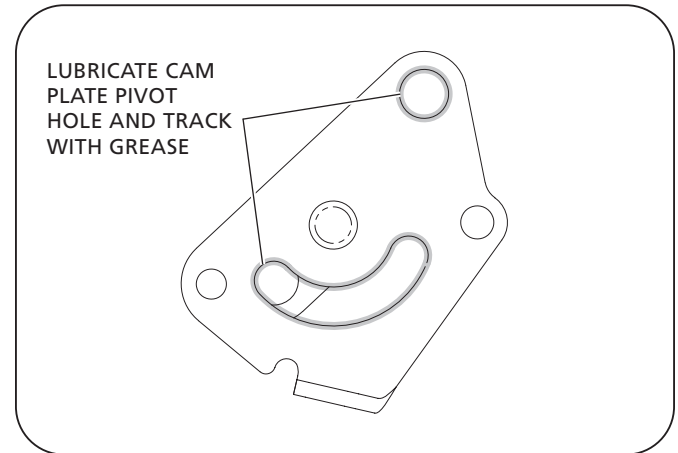

Figure 12

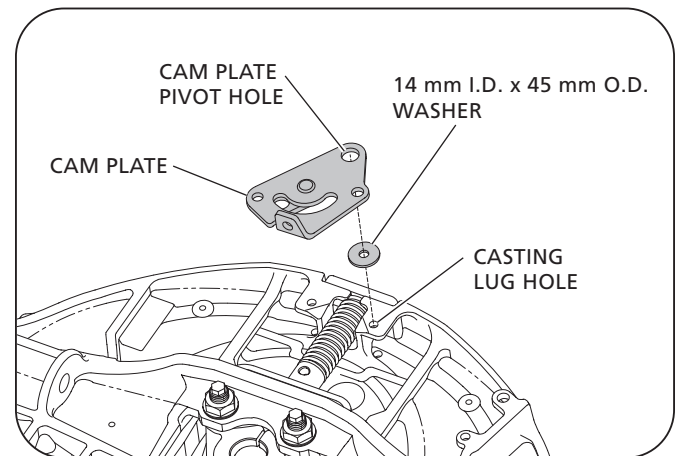
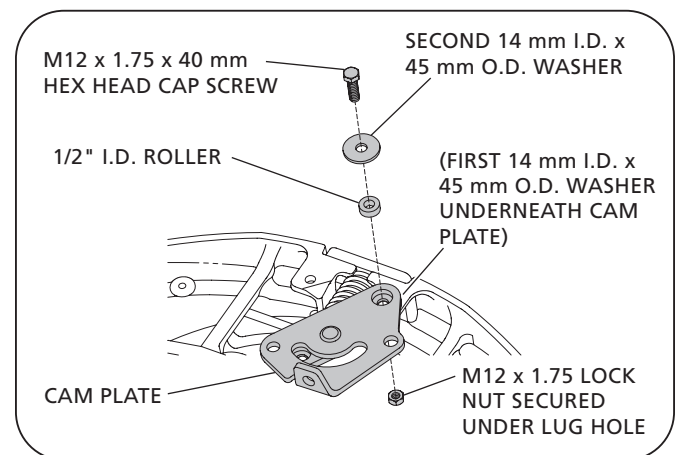

Figure 13



7. The cam plate has a link pre-installed beneath it. Align the hole in the link and the cam plate track over the threaded hole in the yoke (**Figure 14**).
8. Place a 5/8" I.D. roller into the hole in the link. Then place the 5/8" I.D. x 1-3/4" O.D. washer over the cam plate and above the roller with the rounded side of the washer facing the cam plate (**Figure 14**).
9. Check the alignment of the threaded hole in the yoke with the recessed hole in the yoke shaft. (Refer back to **Figure 8**.)
10. Install the M16 x 2 x 50 mm hex head cap screw through the washer, cam plate track, cam plate link, and roller, into the threaded hole in the yoke (**Figure 14**). Hand tighten until the hex head cap screw enters the recessed hole in the yoke shaft.
11. Tighten the hex head cap screw further until it bottoms out in the yoke shaft. Ensure the gap between the washer and the cam plate is no more than .120" (3.04 mm) and no less than .06" (1.52 mm). Then check for free movement of the cam plate (**Figure 15**).

Figure 14

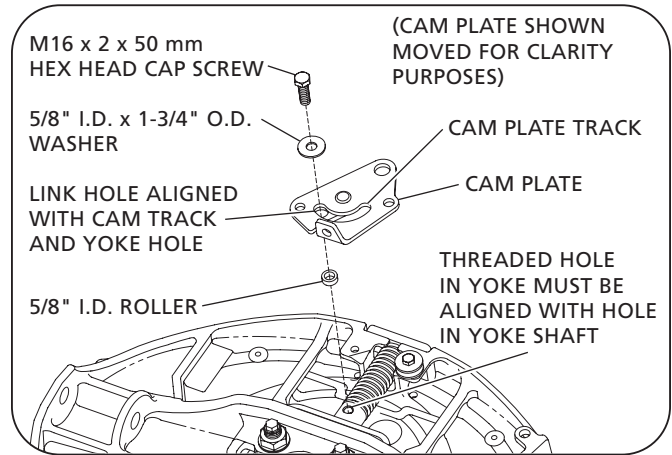
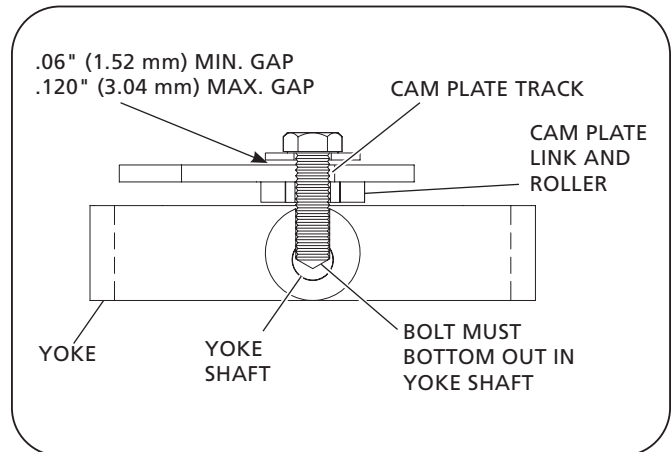

Figure 15



7. Secondary Lock Installation

1. Start the roll pin into the casting lug hole, opposite where the cam plate is installed (**Figure 16**).
2. Assemble the secondary lock to the torsion spring as illustrated (**Figure 16**), then position and align between the casting lug and the casting hole beneath (**Figure 17**). The spring flats must rest against the casting post underneath the casting lug (**Figure 17**).
3. Drive the roll pin through the casting lug hole, torsion spring, and secondary lock, and then into the next hole in the top plate casting until flush with the casting lug (**Figure 17**).
4. Check for proper spring tension and operation by pulling the secondary lock out and allowing the spring to snap it closed.
5. Lubricate the post (roll pin) on the secondary lock where it contacts the cam plate (**Figure 16**), with water-resistant lithium-based grease.

Figure 16

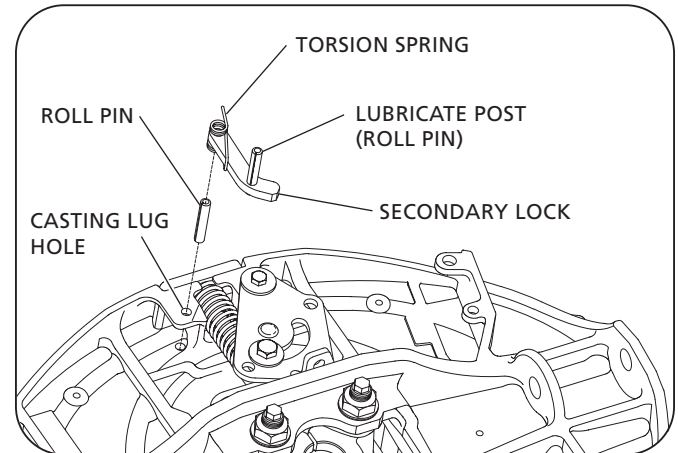
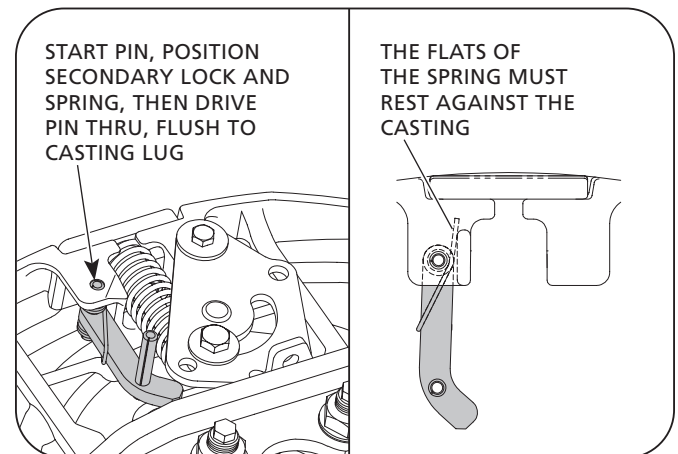

Figure 17



8. Cam Spring Installation

1. Insert the smaller cam spring through the larger cam spring and align the flats of the spring loops (**Figure 18**).
2. Insert the clevis pin through the hole in the mounting tab shown in **Figure 18**, with the head of the pin nearest the fifth wheel top plate surface (**Figure 19**).
3. With the flats of the cam springs nearest the fifth wheel top plate surface, loop the larger cam spring end through the hole in the clevis pin followed by the smaller spring in the opposite direction, as illustrated (**Figure 19**).
4. Insert the opposite ends of the cam springs through the spring tab on the cam plate in the same manner (**Figure 18**).

Figure 18

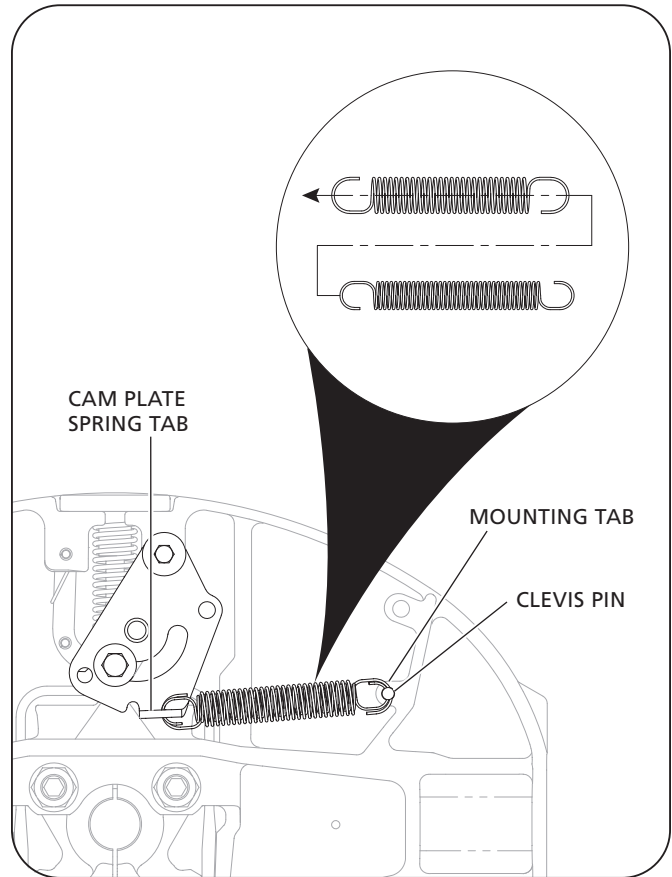
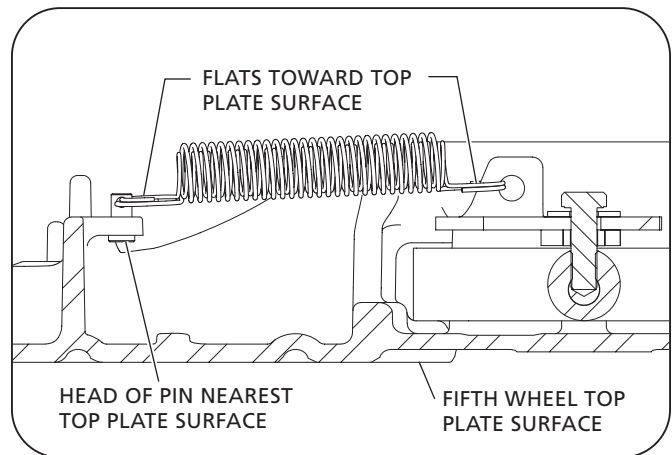

Figure 19



9. Air Cylinder Installation

Refer to **Figure 20** for the following steps for air cylinder installation:

1. Install a bushing into the hole of the cam plate. Place the 5/8" I.D. x 1-1/4" O.D. washer on the underside of the cam plate, aligned with the bushing. Orient the air cylinder so the air fitting port faces the cam springs (see illustration) and position the air cylinder clevis over the cam plate, bushing and washer, aligning the holes.

NOTE: Ensure that the air cylinder clevis in this step is the one on the rod end of the air cylinder.

2. Feed a M12 x 1.75 x 40 mm hex head cap screw up through the aligned holes, and loosely secure with a M12 x 1.75 lock nut. (The head of the cap screw **MUST** be toward the fifth wheel top plate surface.)
3. Install the remaining bushing into the hole of the mounting tab on the casting and position the remaining air cylinder clevis over it, aligning the holes.
4. Feed the remaining M12 x 1.75 x 40 mm hex head cap screw up through the aligned holes, with the head of the cap screw toward the fifth wheel top plate surface, and secure with the remaining M12 x 1.75 lock nut. Complete installation of the air cylinder by tightening the first lock nut.

Figure 20

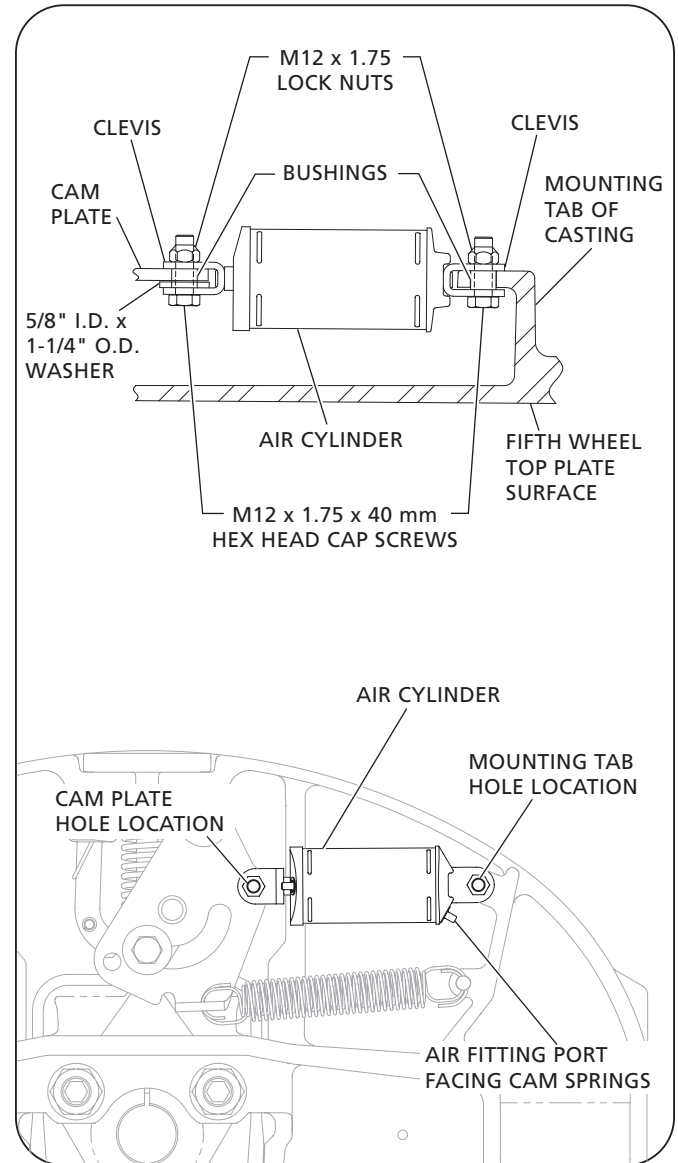

10. Upshock Cushions, Pocket Inserts and Brackets Inspection

To determine if upshock cushions, pocket inserts and/or brackets require replacement, pry up on the fifth wheel top plate pivot ear using a small bar (**Figure 21**). If there is more than 1/4" (6.4 mm) free vertical movement, the top plate should be removed for further inspection. (Refer to Section 3 for top plate removal instructions.)

Upshock Cushions:

1. Standard Cushion (**Figure 22**):

Replace if:

- The hole is elongated to more than 1-3/8" (34.9 mm).
- The upshock cushions are cracked, cut or otherwise severely damaged.

2. ILS-Style Cushion (**Figure 23**):

Replace if:

- The hole is elongated to more than 1-1/2" (38.1 mm).
- The upshock cushions are cracked, cut or otherwise severely damaged.

Figure 21

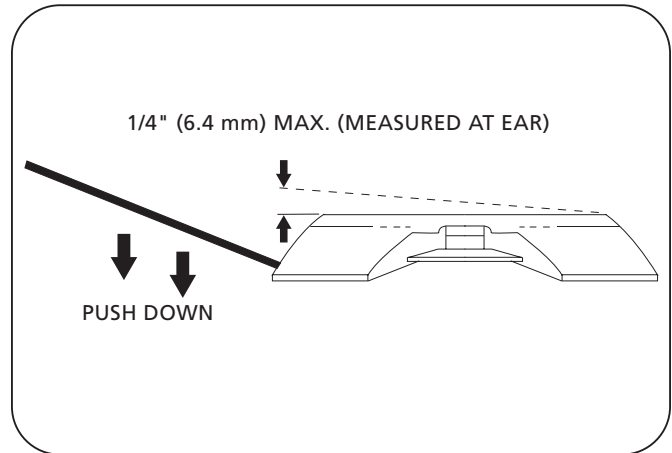

Figure 22

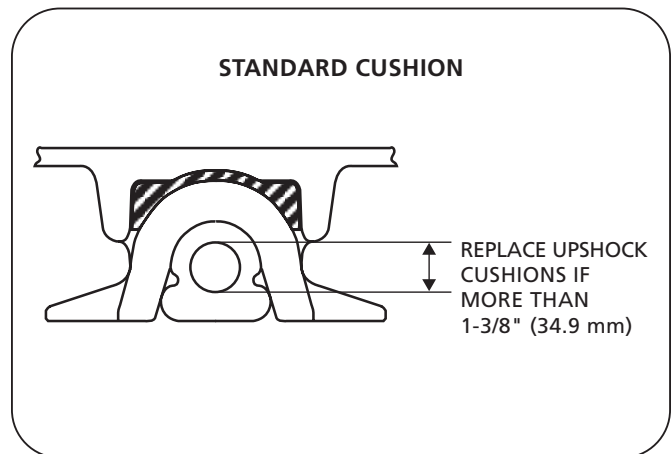
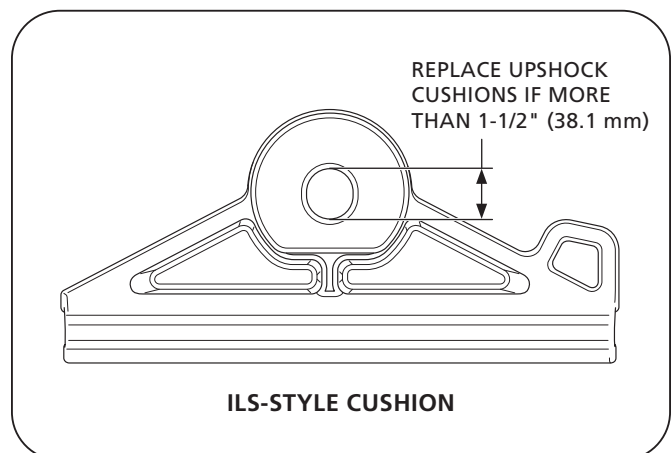

Figure 23



Pocket Inserts (Figure 24):

Replace if:

- The thickness of the pocket insert is 1/16" (1.6 mm) or less.
- The pocket inserts are severely chipped, cracked or gouged.

Brackets:

1. Standard Bracket (Figure 25) and ILS-Style Bracket (Figure 26):

Replace if:

- The thickness of the bracket cap at the top is less than 3/8" (9.5 mm) when measured approximately 1/4" (6.4 mm) in from the edge.
- The brackets are gouged, cracked or otherwise severely damaged.

Figure 24

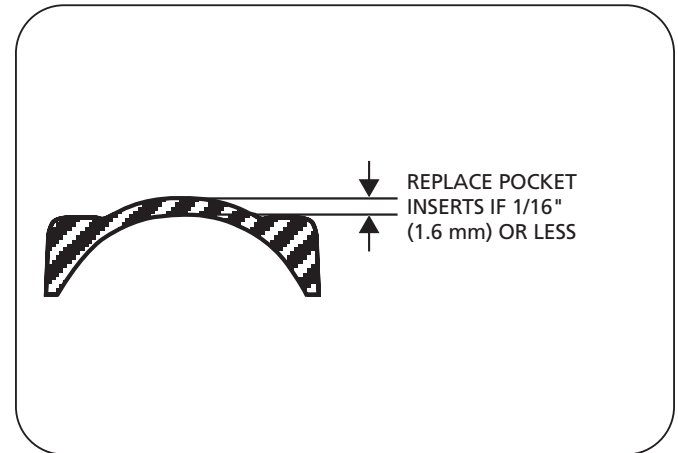

Figure 25

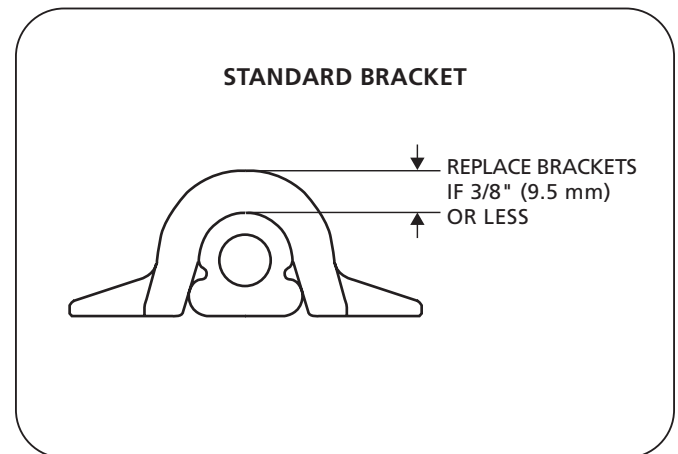
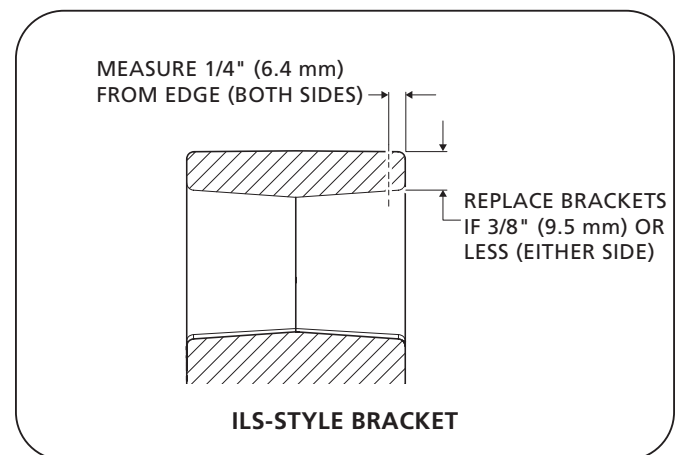

Figure 26



11. Top Plate Installation

1. If the pocket inserts are dislodged from the fifth wheel casting, clean the pocket areas of the casting and apply a strip of double-face tape into the bottom of each pocket. Install the pocket inserts by pressing them down firmly into the pocket areas (**Figure 27**).
2. Check the air lines for signs of chafing or other damage, and check the control valve for proper operation.
3. Using a lifting device capable of lifting 500 lbs. (227 kg), install the fifth wheel top plate onto its mounting base.

NOTE: Follow the instructions published by the lifting device manufacturer for proper operation of the lifting device.

4. Install the bracket pins through the fifth wheel casting and mounting base and secure by installing a clinch pin into each bracket pin (**Figure 28**).
5. Reattach air lines and lube lines as necessary.

Figure 27

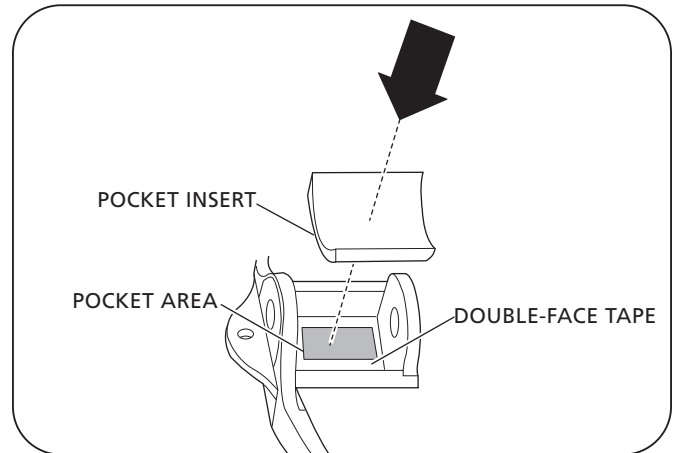
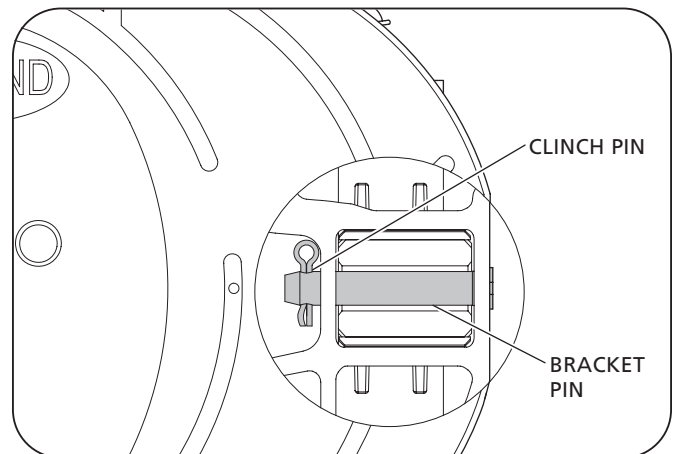

Figure 28



12. Operation Check

1. To check operation of the fifth wheel, use HOLLAND lock tester (Part No. TF-TLN-5001) to close the fifth wheel locks. Verify that the locks are properly closed around the lock tester. Activate the fifth wheel release switch and remove the lock tester. Repeat this step three (3) times to verify proper operation (**Figure 29**).

NOTE: HOLLAND lock tester (Part No. TF-TLN-5001) is available from a local HOLLAND distributor.

NOTE: To operate a TF-TLN-5001 lock tester, refer to Document No. XL-FW10082ST-en-US, available on the internet at www.safholland.us, which contains specific lock tester instructions.

After three (3) successful operational checks, the fifth wheel will be ready for operation.

IMPORTANT: Before using the fifth wheel, visually inspect all components of the fifth wheel for proper operation while coupling and uncoupling the fifth wheel with the lock tester.

⚠ WARNING Failure to repair an improperly operating fifth wheel could result in tractor-trailer separation which, if not avoided, could result in death or serious injury.

IMPORTANT: Be sure to read and understand the fifth wheel operation instructions published in Document No. XL-FW20135UM-en-US (XA-351-TT and XA-351-UBT Owner's Manual) available on the internet at www.safholland.us prior to use.

⚠ WARNING Failure to read and understand fifth wheel operation instructions prior to use could result in improper operation of the fifth wheel which, if not avoided, could result in death or serious injury.

Figure 29

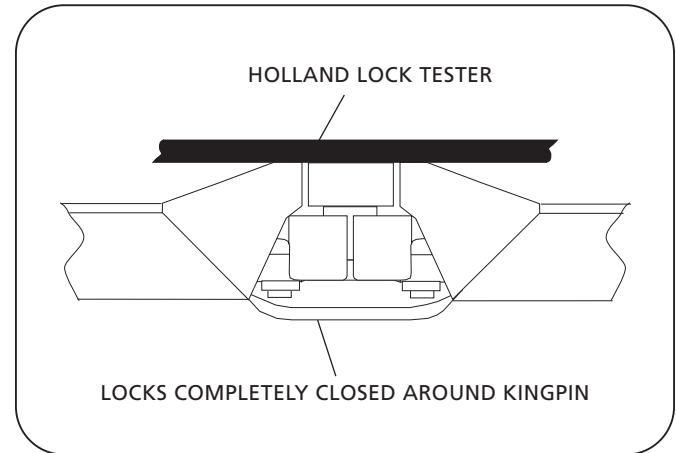



From fifth wheel rebuild kits to suspension bushing repair kits, SAF-HOLLAND Original Parts are the same quality components used in the original component assembly.

SAF-HOLLAND Original Parts are tested and designed to provide maximum performance and durability. Will-fits, look-alikes or, worse yet, counterfeit parts will only limit the performance potential and could possibly void SAF-HOLLAND's warranty. Always be sure to spec SAF-HOLLAND Original Parts when servicing your SAF-HOLLAND product.

SAF-HOLLAND USA • 888.396.6501 • Fax 800.356.3929
www.safholland.us

SAF-HOLLAND CANADA • 519.537.3494 • Fax 800.565.7753
WESTERN CANADA • 604.574.7491 • Fax 604.574.0244
www.safholland.ca

SAF-HOLLAND MEXICO • 52.55.5362.8743 • Fax 52.55.5362.8743
www.safholland.com.mx

info@safholland.com