

### FW6170 Railcar Hitch

Vertical Load: 15 tonnes

Coupling Height (adjustable):  
880, 980 and 1130 mm

Weight: 353 kg

Suitable for trailers with 2" Kingpin



### WARNING

Failure to read, understand and follow the important information contained herein may result in a hazardous condition, or cause a hazardous condition to develop.

Relative to railcar hitch operations, there are other checks, inspections and procedures not listed here which are necessary, prudent and /or required by law. The following is in

addition to these and pertain to the railcar hitch only.

Perform these procedures with the area clear of obstacles and other personnel.

This product is designed and intended for use only with a "reach stacker" or crane type trailer loading and unloading.

## OPERATING INSTRUCTIONS:

### COUPLING PROCEDURES (Loading):

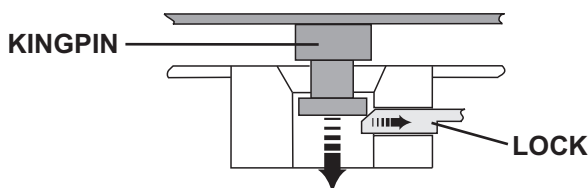
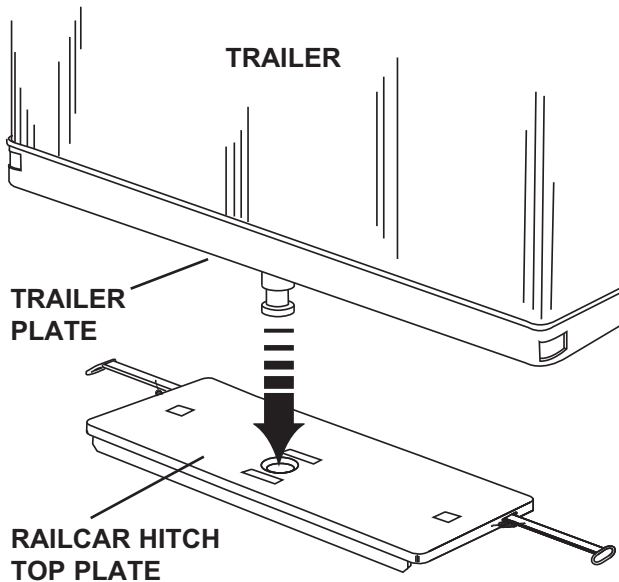

Kingpin automatically retracts lock upon entering "lock opening"

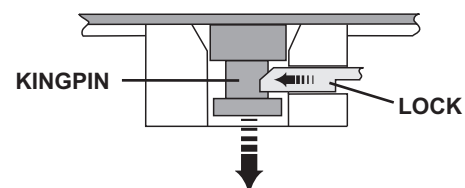

Lock automatically engages as kingpin is lowered into "lock opening"

1. **Check out the railcar hitch before coupling.**
  - A. Inspect the railcar hitch for visible damage prior to each loading operation.
  - B. The railcar hitch must be properly lubricated.
  - C. Check that the correct railcar hitch height has been selected.
  - D. The railcar hitch is locked prior to loading and must not be opened.
2. **Coupling operation.**
  - A. The trailer must be positioned over the railcar hitch, so that the kingpin is directly above the guide ring.
  - B. The trailer should be lowered until the trailer plate is in contact with the railcar hitch top plate and the kingpin is correctly located in the guide ring.

**NOTE:** The locking mechanism automatically opens when the kingpin is entered into the guide ring and subsequently locks automatically.

**COUPLING PROCEDURE (continued):**

**3. Inspection of the railcar hitch after loading.**

A. The kingpin must be fully inserted into the guide ring and there must be no gaps between the trailer plate and the railcar hitch top plate.

**✓ CORRECT**

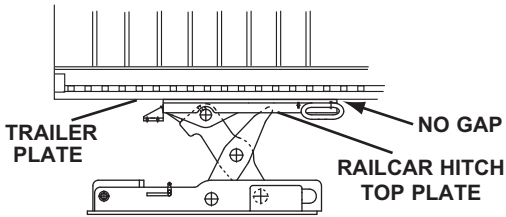

Kingpin is properly engaged.

**✗ WRONG**

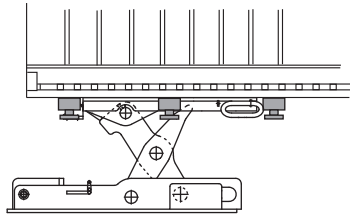

Kingpin is in front of, behind, or to the side

**✗ WRONG**

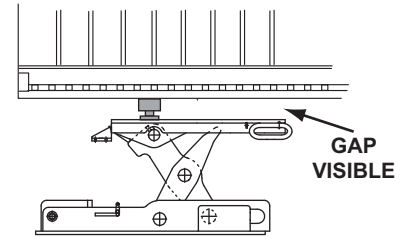

Kingpin is on the top.

B. The operating handle is in the fully retracted position and the retaining notch no longer visible.

**✓ CORRECT**

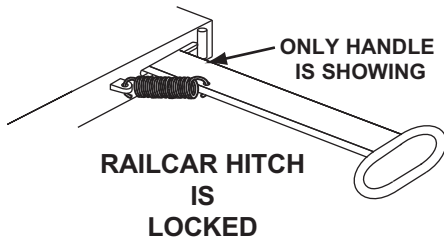

**✗ WRONG**

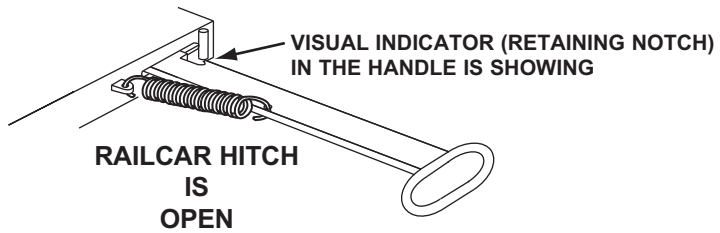

**UNCOUPLING PROCEDURE (Unloading):**

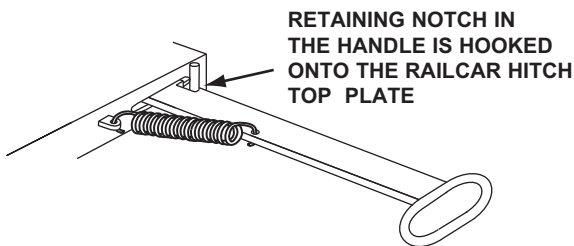

A. Pull the operating handle fully outwards and hook it on to the retaining notch - The railcar hitch is now open and the trailer can be lifted off

**NOTE:** After the trailer is lifted off the railcar hitch the locking mechanism returns into the locked position

## SETTING UP THE RAILCAR HITCH HEIGHT:

The railcar hitch FW6170 can be set at three coupling heights in order to be loaded with different types of trailers. In the lowered position the railcar hitch allows the wagon to be loaded with standard containers

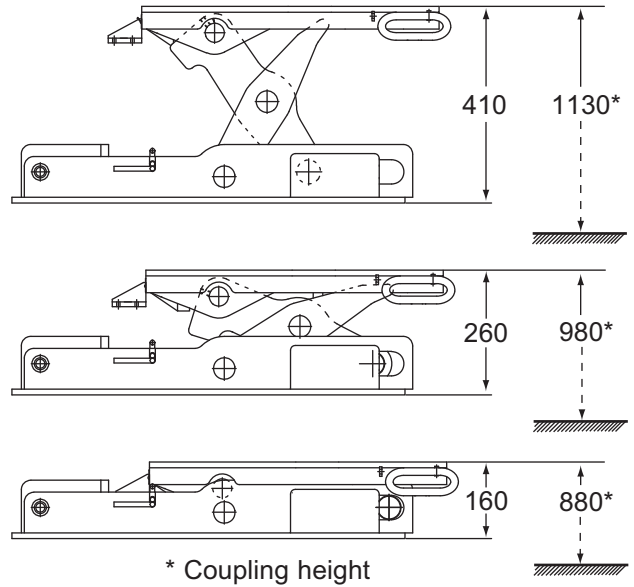

1. In order to adjust the height of the railcar hitch the operating handle (1) has to be pulled out (A) and then hung up by moving it upwards
2. Put the crank on the driveshaft (2) and set the favoured height by turning the crank set. Once the operation handle snaps back inwards the next height has been reached.
3. In order to be correctly locked the control lever must be located completely under the square block. This will be visible to the correlation of the markings on the locking lever and the base plate (3). If the square is not parallel to the base plane, so the crank must be turned further until the locking lever can pass under the square block. Ignoring this feature may lead to damage of the height lock (For a better understanding the control lever and the square block is shown in the pictures without the cover plate)

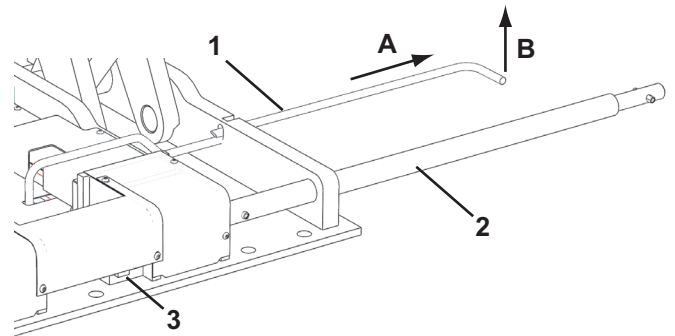

**HEIGHT ADJUSTMENT LOCKED**

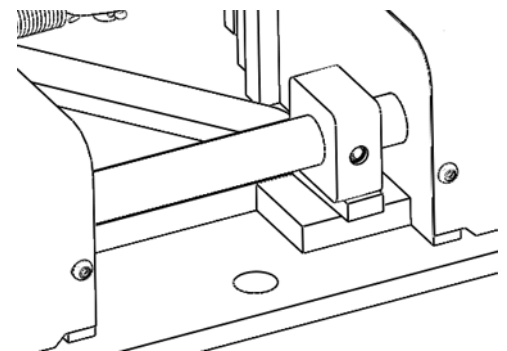

**HEIGHT ADJUSTMENT UNLOCKED**

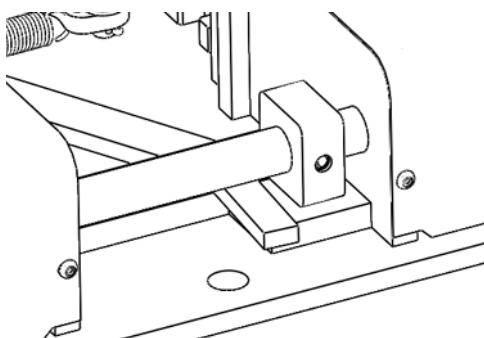

**HEIGHT ADJUSTMENT UNLOCKED**

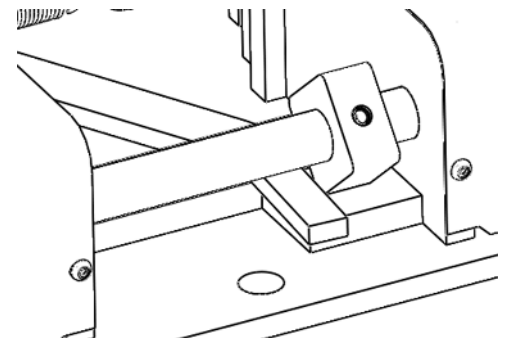

## LUBRICATION

Periodic lubrication of the railcar hitch FW6170 is to be conducted at least every four months by using a water resistant, lithium based grease. We recommend a long-term pressure grease NLGI class 21 with MoS2 or, e.g. MOTOREX. The lubrication intervals must be adapted to the respective operating conditions, shorter and longer intervals are possible. Make sure that all moving parts are clean and adequately lubricated. Attention should be paid especially to the following lubrication points:

1. All parts of the locking mechanism
2. Bevel gear (every 8 months or if required)
3. Spindle
4. Outer surface of the lifting arms
5. Contact surface of sliding frame guide shaft

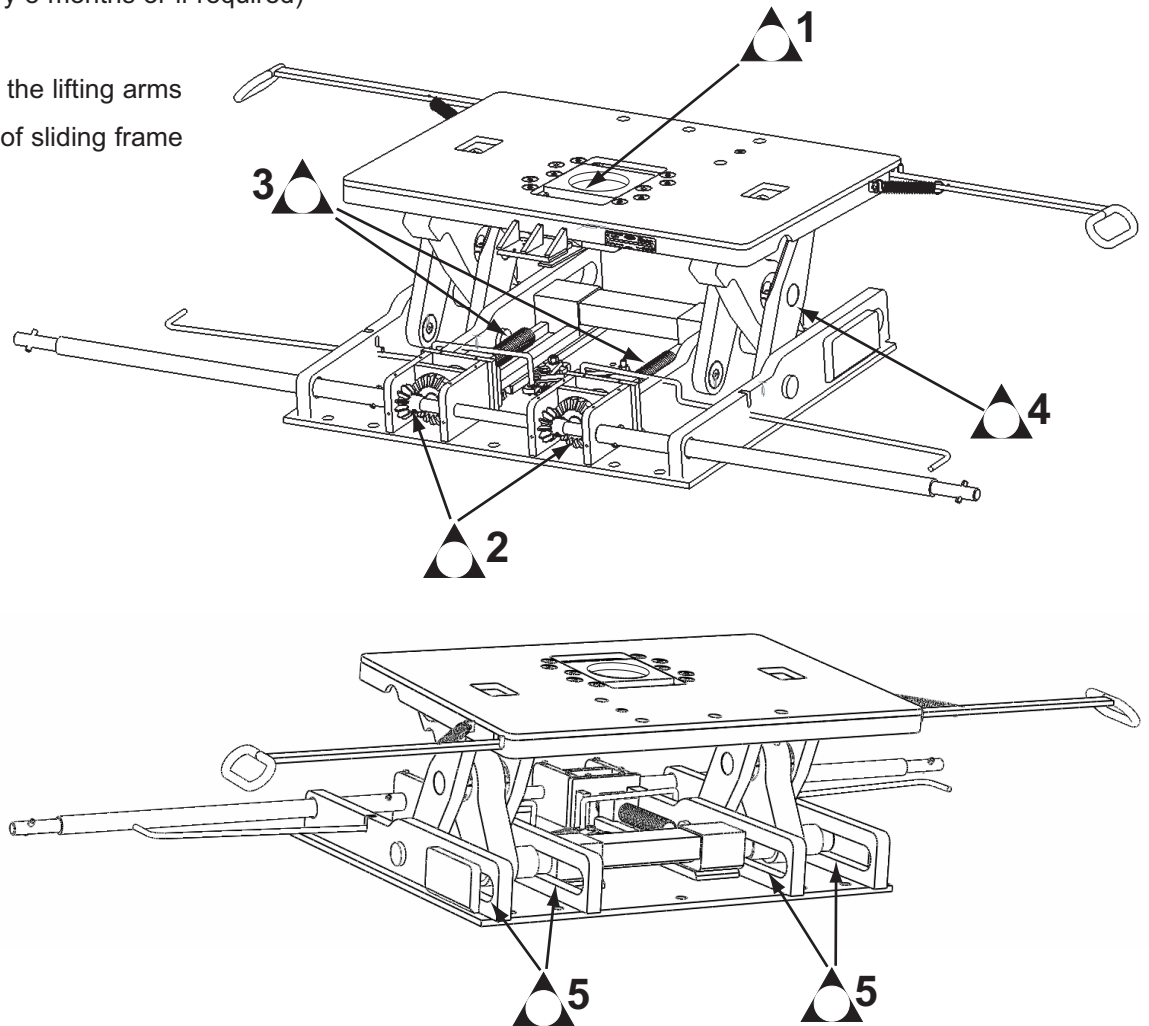

### Notes:

When cleaning the railcar hitch, environmentally harmful substances may be used. We point out that the corresponding current waste regulations of each country must be observed when disposing of this waste.

We recommend the wearing of protective gloves when working with lubricant.

## PERIODICAL MAINTENANCE PROCEDURE:

Maintenance and repair work on the railcar hitch may only be performed by qualified personnel at certified specialist workshops. In this regard, special hazards must be taken into account if SAF-Holland Verkehrstechnik original parts are not used or retaining elements are used more than once.

The periodic inspection and maintenance procedures for the railcar hitch are to be performed every four months, but this frequency is depending upon its usage. At each service the railcar hitch has to be checked for damage and to be repaired when indicated. The function of the railcar hitch has to be checked after every service.

1. Check the complete railcar hitch thoroughly. Replace any missing or damaged bolts and nuts.
2. Check the locking mechanism for damage and for proper operation.
3. Check the operation handles for damage. Make sure the handles are not bent.
4. Check the operation handle springs. Missing or damage springs must be replaced.



Shock absorber elements which have become deformed, or which have fallen out of the top plate must be replaced immediately.

**Important! Failure to follow these instructions could result in an accident**

### Checking the torque of the shock absorber elements

The torque of the screws for fixing the shock absorber elements must be checked every 8 months

1. Release lock nuts (1)
2. Tighten screws (2) with a torque wrench SW30. Torque  $M_d=115$  Nm
3. Tighten the lock nuts

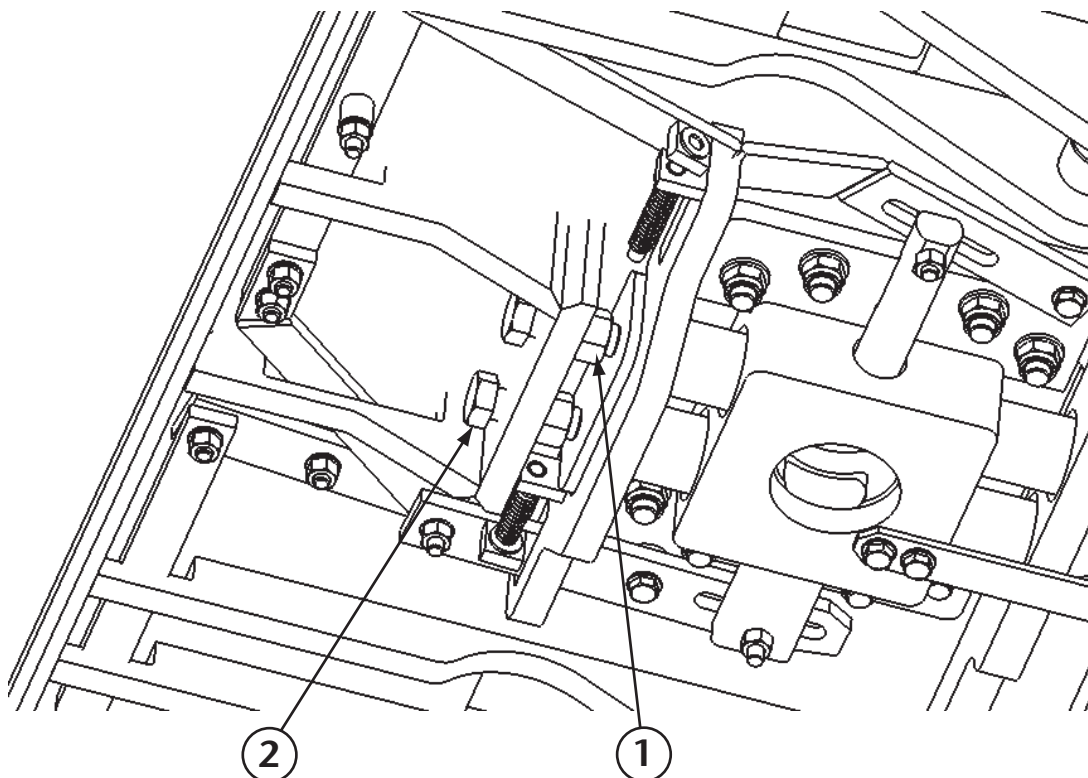

## MAINTENANCE - DAMAGE EVENT

### Shock Absorber Elements

In case of a shock in the longitudinal direction of the TWIN-wagon the Shock Absorbers can be damaged. In this case the wagon may continue only after appropriate securing of the semi-trailer and has to be transported under the conditions of the railway company



Danger

When the Shock Absorbers are compressed after a collision, all parts of the railcar hitch, especially the locking mechanism and the king pin must be checked for damage. Damaged parts must be replaced immediately.

**Important! Failure to follow these instructions could result in an accident**

The shock absorbers and the lock plunger can be replaced with the railcar hitch in situ. In this case the railcar hitch must be in the upper position.

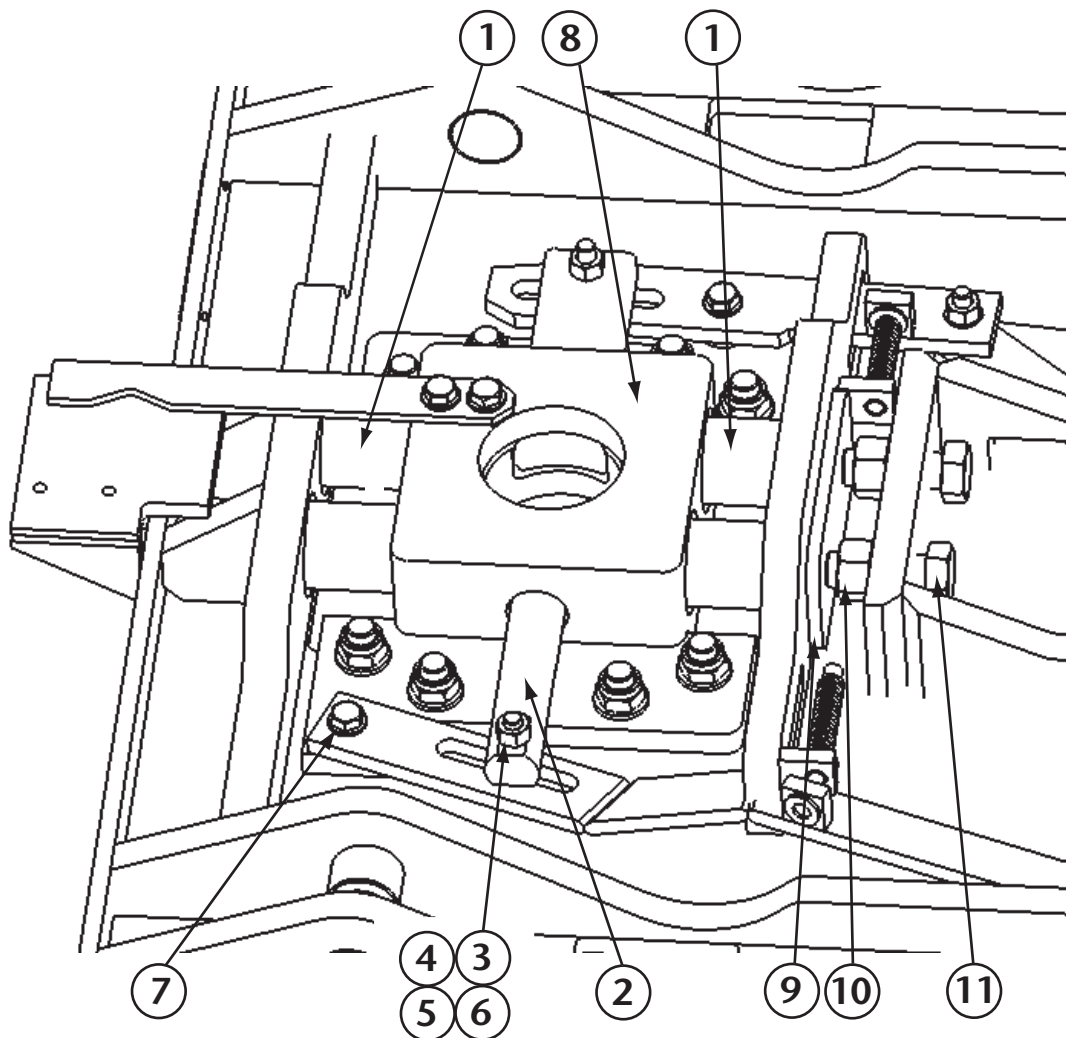

<b>TOOL LIST</b>	Quantity	Shock Absorber	Lock Plunger
Torque Wrench	1	X	X
Hexagon socket size 30	1		X
Hexagon socket size 17	1	X	X
Ring / open ended spanner size 30	1	X	X
Ring / open ended spanner size 17	2		X

## Replacement of the Shock Absorber Elements

1. Loosen the lock nut (10) and the bolt (11)
2. Remove pressure plate (9)
3. Slide guide ring (8)
4. Remove old shock absorber elements (1)
5. Insert new shock absorber elements
6. Insert pressure plate and tighten the bolt.  
Torque Md = 115 Nm
7. Secure bolt with lock nut (10)

Item	Description	Part No.	Quantity
1	Shock absorber	XB-76033	4

## Replacement of the Shock Absorber Elements and the Lock Plunger

1. Loosen the lock nut (10) and the bolt (11)
2. Remove old shock absorber elements (1)
3. Loosen the nut (6) and remove damaged lock plunger (2)  
Inspect all parts of the locking mechanism for damage!
4. Loosen bolt (7) for more clearance on the release arm
5. Fit bolt (3) in correct order with washer (5) onto the release arm
6. Tighten down the bolt for the release arm (7)
7. Fit bushing (4) on bolt (3) and fasten new lock plunger with nut (6)
8. Fit new shock absorber elements between guide ring (8) and pressure plate (9)  
and fix it with bolt (11). Torque Md = 115 Nm
9. Secure bolt with nut (10)

Item	Description	Part No.	Quantity
1	Shock absorber	XB-76033	4
2	Lock plunger	XA-76033	1
3	Bolt M10 x 50	31032	1
4	Bushing	XA-76166	1
5	Washer	33023	1
6	Nut M10	32008	1

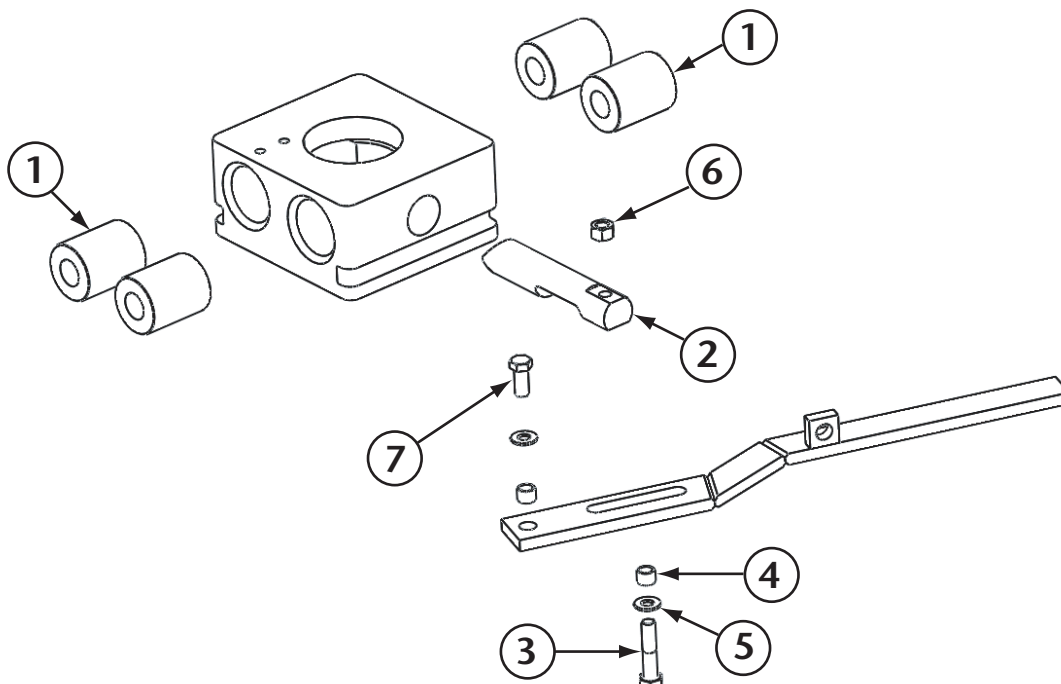

## Replacement of the operating handle

The operating handle can be replaced with the railcar hitch in situ. The railcar hitch must be in the upper position.

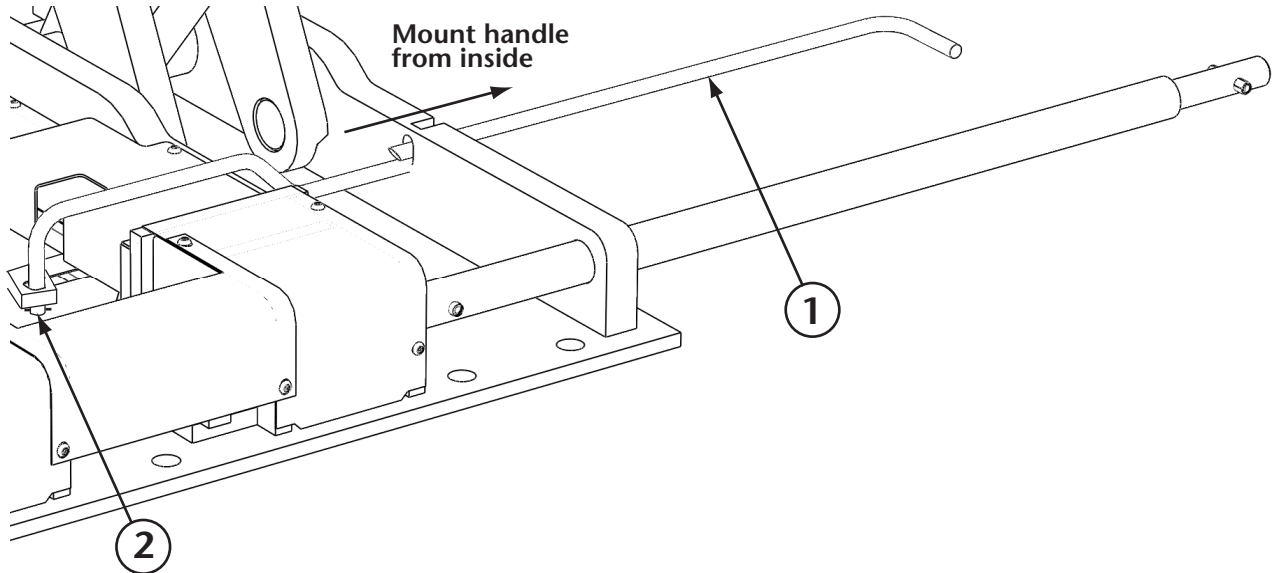

1. Remove split pin (2)
2. Remove the old operating handle
3. Mount new operating handle (1) from inside
4. Fix operating handle with new split pin

Item	Description	Part No.	Quantity
1	Operating Handle	XA-76131	1
2	Split Pin	XA-76044-1	1





SAF-HOLLAND Group

# RAILCAR HITCH TOP PLATE ASSEMBLY XA-76101

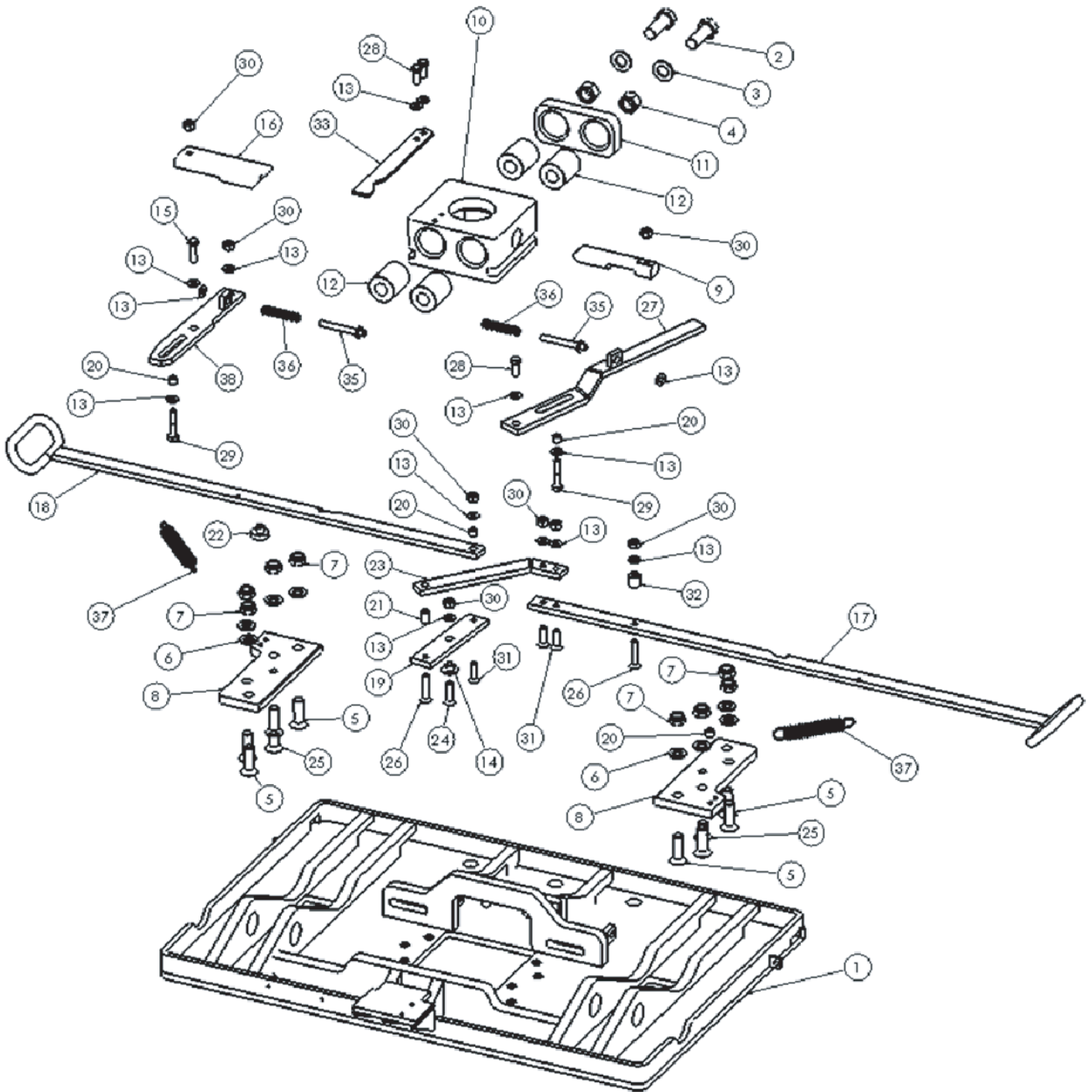

**NOTE:** For simplification the top plate assembly is shown upside down



SAF-HOLLAND Group

## PARTS LIST FOR TOP PLATE ASSEMBLY XA-76101

ITEM	PART NO.	NO. REQ'D	PART NAME
1	XA-77144	1	Top plate
2	XB-76030	2	Hex. bolt, M20 x 55
3	XB-76032	2	Washer, Plain Ø20
4	XB-76031	2	Nut M20
5	XB-76023-1	8	Countersunk bolt M16 x 50
6	XB-76025	8	Washer Ø16
7	XB-76026-1	8	Locknut M16
8	XA-76152	2	Guide plate
9	XA-76163	1	Release bolt
10	XA-76168	1	Guide Ring
11	XA-76157	1	Pressure Plate
12	XB-76033	4	Shock Absorber Element
13	33023	13	Washer Ø10
14	XA-76162	1	Bushing
15	XB-76034	1	Hex. bolt M10 x 35
16	XA-76156	1	Lock bolt
17	XA-76159	1	Operating Handle
18	XA-76160	1	Operating Handle
19	XA-76155	1	Control lever
20	XA-76166	4	Bushing
21	XA-76166-1	1	Bushing
22	XA-76167	1	Bushing
23	XA-76158	1	Link lever
24	XB-76028	1	Countersunk bolt M10 x 40
25	XB-76024-1	2	Countersunk bolt M16 x 30
26	XB-76038	2	Countersunk bolt M10 x 45
27	XA-76154	1	Release lever
28	31008	3	Hex. bolt M10 x 25
29	31032	2	Hex. bolt M10 x 50
30	32008	8	Locknut M10
31	31038	3	Countersunk bolt M10 x 35
32	XA-76169	1	Bushing
33	XA-76176	1	Brake actuator
34	XB-76104	1	Bushing
35	XA-76134	1	Spring guide
36	XB-76008	1	Compression spring
37	XB-D-05843-1	2	Extension spring
38	XA-76124	1	Release lever

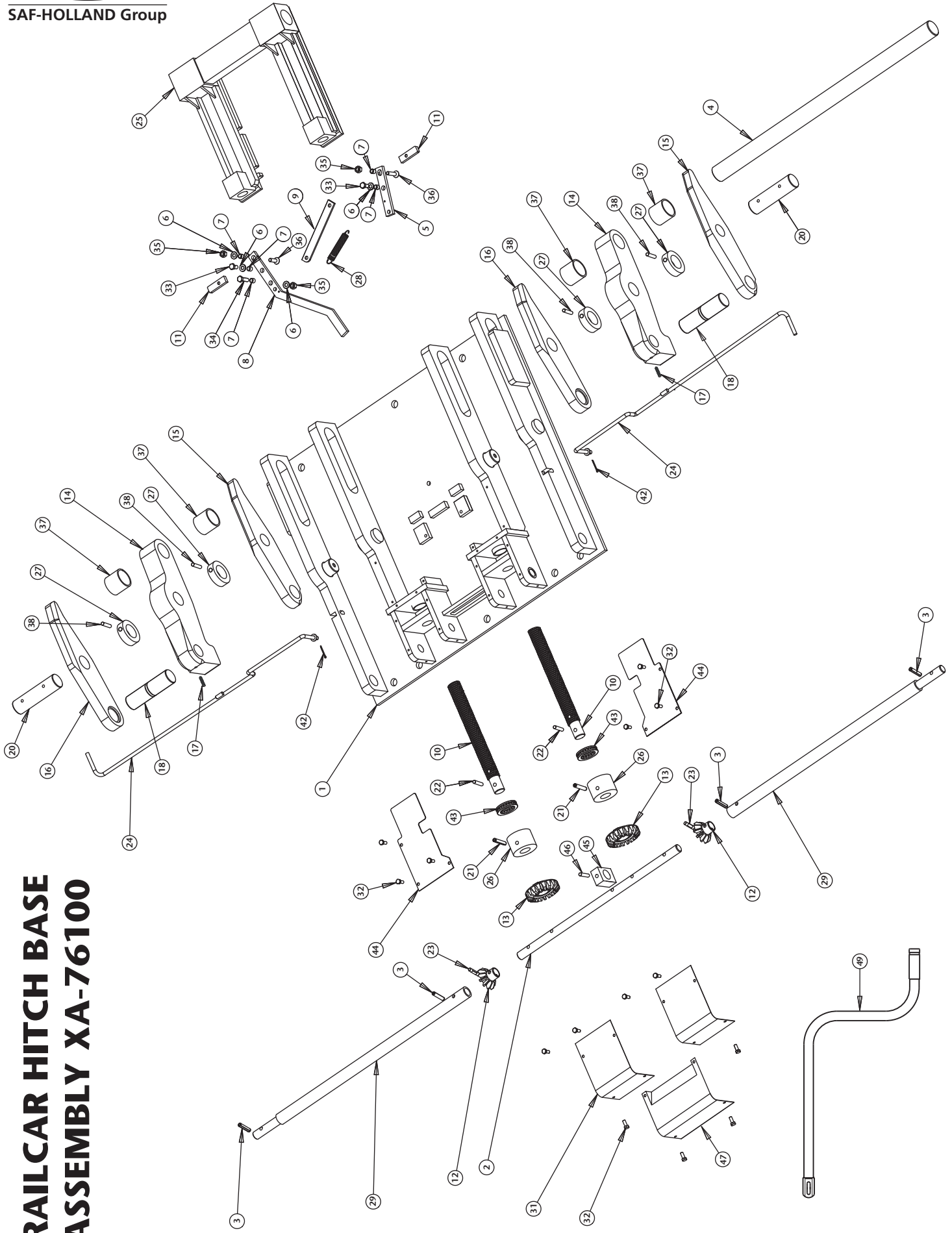

# RAILCAR HITCH BASE ASSEMBLY XA-76100



SAF-HOLLAND Group

## PARTS LIST FOR BASE ASSEMBLY XA-76100

ITEM	PART NO.	NO. REQ'D.	DESCRIPTION
1	XA-76109-A	1	Baseplate
2	XA-76123	1	Drive Shaft
3	XB-E-61135	4	Spring Pin, Ø10 x 45
4	XA-76121	1	Axle
5	XA-76135	1	Lever
6	33023	5	Washer, Ø10
7	XA-76141	5	Bushing
8	XA-76182	1	Control Lever
9	XA-76140	1	Link
10	XA-76125	2	Spindle
11	XA-76137-1	2	Lock Pin
12	XA-76174	2	Gear, Bevel Pinion
13	XA-76232	2	Gear, Bevel
14	XA-76103-B	2	Inner Lifting Arm, complete
15	XA-76105-R	2	Outer Lifting Arm, Right
16	XA-76105-L	2	Outer Lifting Arm, Left
17	XA-76128	2	Hexagon bolt M10 x 80
18	XB-76106-A	2	Top Bolt
19	-	-	-
20	XA-76122	2	Centre Bolt
21	34011	2	Spring Pin, Ø10 x 70
22	XA-CRP-V-06635	2	Spring Pin, Ø3/8" x 2"
23	XB-76705	2	Spring Pin, Ø10 x 35
24	XA-76131	2	Operating Handle
25	XA-76126	1	Sliding Frame
26	XA-76177	2	Spindle Nut
27	XA-76170	4	Spacer bush
28	XA-76040	1	Tension Spring
29	XA-76179	2	Extension Shaft
30	-	-	-
31	XA-76173-A	2	Cover Plate
32	XB-76060	14	Screw, M6 x 12
33	31008	2	Hex bolt, M10 x 25
34	XB-60137	1	Hex bolt, M10 x 30
35	32008	3	Nut, Lock, M10
36	XB-76038	2	Spring pin Ø10 x 45
37	XA-76185	4	Spacer Bush
38	XB-76119	4	Spring pin Ø10 x 60
39	-	-	-
40	-	-	-
41	-	-	-
42	XB-76044-1	2	Split Pin, 3.2 x 32
43	XB-76041-1	2	Deep groove ball bearing
44	XB-76173-B	2	Cover Plate
45	XA-76139	1	Square Block
46	XB-76118	1	Spring pin, Ø10 x 45
47	XA-76173-C	1	Cover Plate
48	-	-	-
49	XA-76114	2	Crank Handle



SAF-HOLLAND Group

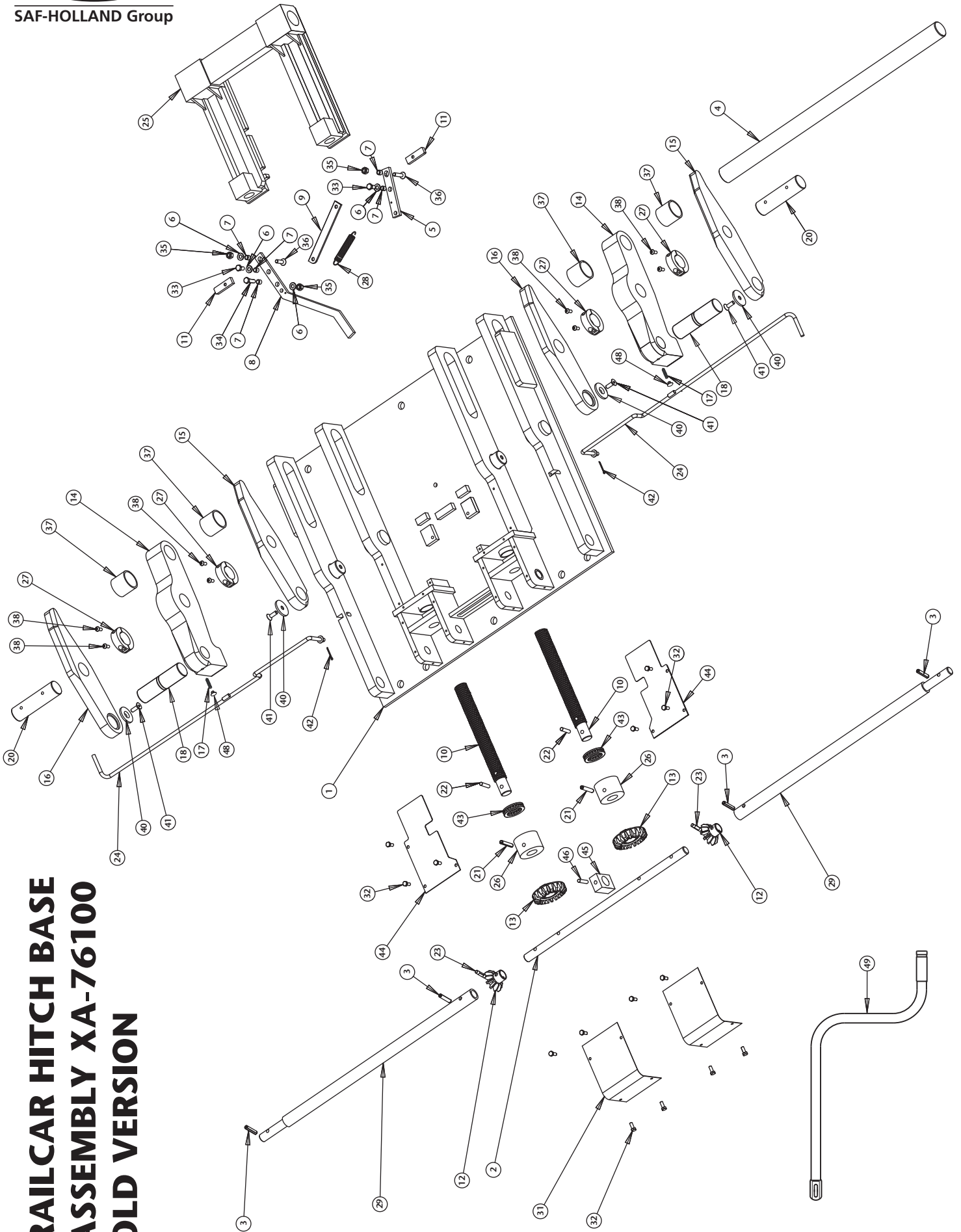

**RAILCAR HITCH BASE  
ASSEMBLY XA-76100  
OLD VERSION**



SAF-HOLLAND Group

## PARTS LIST FOR BASE ASSEMBLY XA-76100 - OLD VERSION

ITEM	PART NO.	NO. REQ'D.	DESCRIPTION
1	XA-76109-A	1	Baseplate
2	XA-76123	1	Drive Shaft
3	XB-E-61135	4	Spring Pin, Ø10 x 45
4	XA-76121	1	Axle
5	XA-76135	1	Lever
6	33023	5	Washer, Ø10
7	XA-76141	5	Bushing
8	XA-76182	1	Control Lever
9	XA-76140	1	Link
10	XA-76125	2	Spindle
11	XA-76137-1	2	Lock Pin
12	XA-76174	2	Gear, Bevel Pinion
13	XA-76232	2	Gear, Bevel
14	XA-76103-A	2	Inner Lifting Arm, complete
15	XA-76105-R	2	Outer Lifting Arm, Right
16	XA-76105-L	2	Outer Lifting Arm, Left
17	XA-76011	2	Hexagon bolt M10 x 80
18	XB-76106	2	Top Bolt
19	-	-	-
20	XA-76122	2	Centre Bolt
21	34011	2	Spring Pin, Ø10 x 70
22	XA-CRP-V-06635	2	Spring Pin, Ø3/8" x 2"
23	XB-76105	2	Spring Pin, Ø10 x 35
24	XA-76131	2	Operating Handle
25	XA-76126	1	Sliding Frame
26	XA-76177	2	Spindle Nut
27	XA-76144	4	Clamp Ring
28	XA-76040	1	Tension Spring
29	XA-76179	2	Extension Shaft
30	-	-	-
31	XA-76173-A	2	Cover Plate
32	XB-76060	14	Screw, M6 x 12
33	31008	2	Hex bolt, M10 x 25
34	XB-60137	1	Hex bolt, M10 x 30
35	32008	3	Nut, Lock, M10
36	XB-76038	2	Spring pin Ø10 x 45
37	XA-76185	4	Spacer Bush
38	XB-76102	8	Cap Bolt M10 x 60
39	-	-	-
40	XA-76119	4	Washer
41	XB-76023	4	Countersunk Bolt M10 x 25
42	XB-76044-1	2	Split Pin, 3.2 x 32
43	XB-76041-1	2	Deep groove ball bearing
44	XB-76173-B	2	Cover Plate
45	XA-76139	1	Square Block
46	XB-76118	1	Spring pin Ø10 x 45
47	-	-	-
48	XB-76012	2	Plastic Cap
49	XA-76114	2	Crank Handle



**SAF-HOLLAND GmbH**  
Hauptstraße 26  
D-63856 Bessenbach, Germany  
Phone: +49 (0) 6095-301302  
Fax: +49 (0) 6095-301200

**SAF-HOLLAND VKT GmbH**  
Julius-Bühner-Str. 12  
78224 Singen, Germany  
Phone: +49 (0) 7731-1443-344  
Fax: +49 (0) 7731-1443-200

Copyright © August 2010-SAF-HOLLAND. All information contained in this document is correct at time of copyright and is subject to change without notification all rights reserved