



ADL SERIES

MAINTENANCE AND PARTS LIST



ADL Series

Drive-Axle Air-Ride Suspension
Maintenance and Parts List Manual

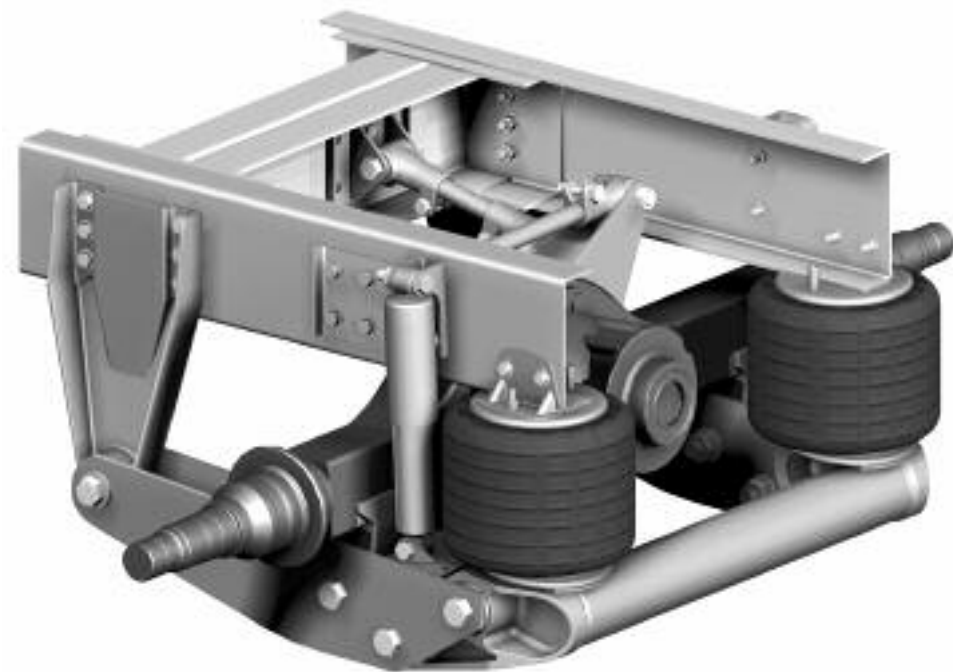

CONTENTS

	Page		Page
Introduction	3	Pinion Angle Adjustment	9
Warranty	3	Service Repair Kits	10
Notes, Cautions, and Warnings	3	Pivot Connection	10
Model Identification	4	Pivot Connection Alignment Block	10
Model Nomenclature	4	ADL-120 Front Transverse Beam Connection	10
Disc Brake Compatible Suspension.....	4	ADL-123 Front Transverse Beam Connection	10
Disc Brake Compatible Beams	4	Rear Transverse Beam Connection	11
Operating and Maintenance Instructions	5	Axle Connection	11
ADL Suspension Operation	5	Torque Rod and Track Bar Bushing	11
Routine Maintenance and Daily Inspection.....	5	Part Replacement Instructions	12
Initial 5,000 Mile (8,000 km) or 100 Hours of Service Inspection	5	Suspension Air Springs	12
Routine Maintenance – 50,000 Miles (80,000 km) or 1,000 Hours of Service or as Needed	5	Axle Adapter Bushing	13
General Information	5	Frame Bracket Pivot Bushing	14
Pre-Operational Checklist	6	Transverse Beam Bushing	15
ADL-120 Parts List	7	Shock Absorbers	16
Suspension Adjustment Instructions	8	Torque Rod	17
Ride Height	8	Track Bar	18
Axle Alignment	8	Troubleshooting	19
		Contact Information	20

INTRODUCTION

This manual provides you information necessary for the care, maintenance, inspection, and safe operation of Holland's ADL Series drive-axle suspension models.

The Holland Suspension is designed and engineered to provide trouble-free service. In the event of minor breakdown, such as a loss of air in the air springs, there are safety features designed into the suspension that will allow the vehicle to be driven CAUTIOUSLY at slow speed, to the nearest service facility. Be sure tire clearance remains adequate with the underside of the body and equipment.

This suspension uses air drawn from the vehicle's air system to pressurize the air springs. The height control valve regulates the air pressure required for varying loads and maintains the design ride height.

NOTE: Contact the vehicle OEM or Dealer Service Center with all service/maintenance questions.

WARRANTY

Refer to the complete warranty for the country in which the product will be used. A copy of the written warranty is included with the product as well as in the suspension catalogs and the Holland Group Web Site (www.thehollandgroupinc.com).

It may also be ordered by calling 1-888-396-6501.

NOTES, CAUTIONS, AND WARNINGS

You must read and understand all of the safety procedures presented in this manual before starting any work on the suspension.

Proper tools must be used to perform the maintenance and repair procedures described in this manual. Many of these procedures require special tools.

Failure to use the proper equipment could result in personal injury and/or damage to the suspension.

Safety glasses must be worn at all times when performing the procedures covered in this manual.

Throughout this manual, you will notice the terms "NOTE," "IMPORTANT," "CAUTION" and "WARNING" followed by important product information. So that you may better understand the manual, those terms are as follows:

NOTE: Includes additional information to enable accurate and easy performance of procedures.

IMPORTANT: Includes additional information that if not followed could lead to hindered product performance.

CAUTION Used without the safety alert symbol, indicates a potentially hazardous situation which, if not avoided, may result in property damage.

CAUTION Indicates a potentially hazardous situation which, if not avoided, may result in minor or moderate injury.

WARNING Indicates a potentially hazardous situation which, if not avoided, could result in death or serious injury.

MODEL IDENTIFICATION

A serial number tag is attached to the underside of the transverse beam for identification purposes (**FIGURE 1**). This tag supplies valuable information regarding the exact components used to manufacture the suspension.

FIGURE 1
Serial Number Tag Location

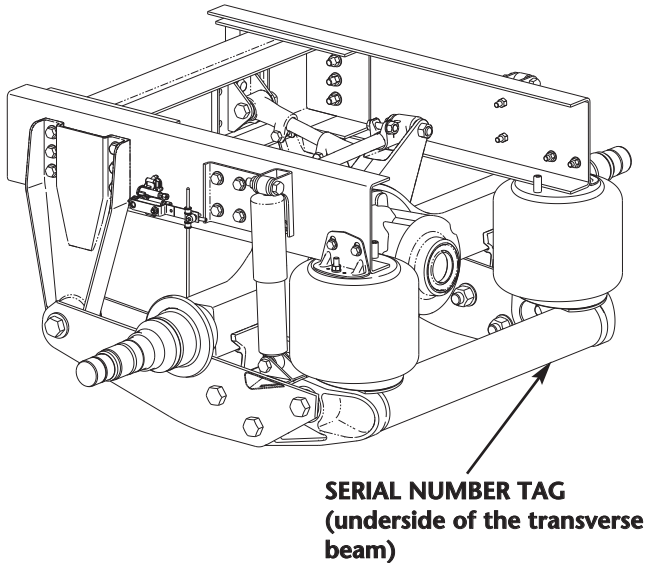

Depending upon OEM configuration, the serial number tag may not call out the exact kit or parts list number. If so, the vehicle OEM should be able to identify the suspension model and its components using the vehicle's VIN number.

IMPORTANT: Due to some OEMs using several variations of parts, having the exact parts used by the OEM is critical in determining proper replacement components.

It is recommended that you determine your specific model number, write that information below, and refer to it when obtaining information or replacement parts.

Model Number _____
 Parts List Number _____
 Serial Number _____

MODEL NOMENCLATURE

AIR DRIVE
 NO. OF AXLES
 1 - SINGLE
 RATED CAPACITY (X 1,000 LBS.)
 RIDE HEIGHT (INCHES)
ADL - 1 20 - 7

IMPORTANT: This manual applies to the ADL suspension series and for special orders of the same. It is very important to determine your specific model number, serial number, and parts list number. Record those numbers on this page, and refer to them when obtaining information or replacement parts.

Single Axle:
 ADL-120
 ADL-123

FIGURE 2
Serial Number Tag

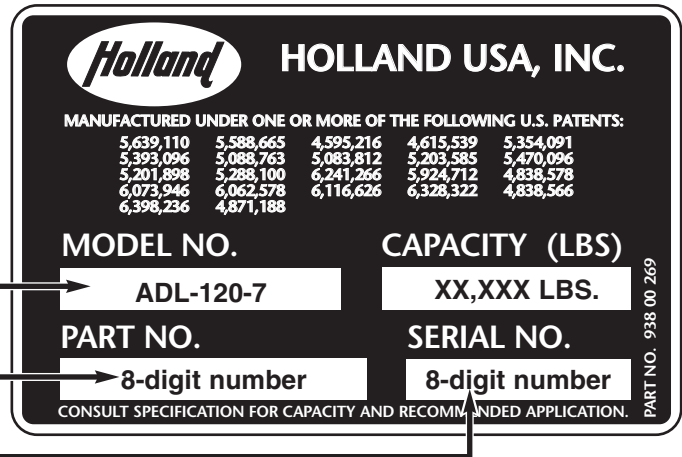

DISC BRAKE COMPATIBLE SUSPENSION

Disc Brake Compatible Beams

Disc brake compatible beams are shown in **FIGURE 3** and are used in selected illustrations throughout the manual.

FIGURE 3
Disc Brake Compatible Equalizing Beams

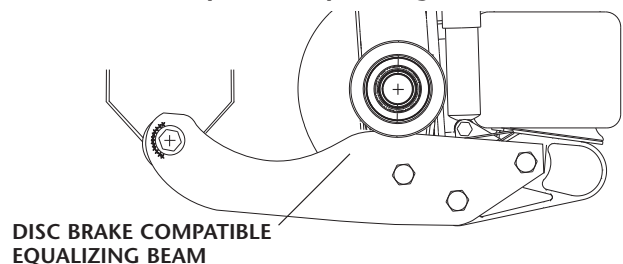

OPERATING AND MAINTENANCE INSTRUCTIONS

ADL Suspension Operation

The ADL Series Suspension is controlled by either one or two height control valves. When properly adjusted, they automatically maintain the specified ride height throughout the unloaded to loaded range. The height control valve automatically adds air to, or exhausts air from, the suspension to maintain a constant ride height.

Before putting the vehicle in operation, build air pressure in excess of 100 psig (6.9 bars). This will open the pressure protection valve and allow air flow to the height control valves.

IMPORTANT

Routine Maintenance and Daily Inspection

Daily Inspection

Daily or before each trip, check the suspension to be sure it is fully operational. Visually inspect air springs for equal firmness and to see that suspension is set at proper ride height. See page 8 for ride height measurement and re-setting instructions. Service as necessary.

Initial 5,000 Mile (8,000 km) or 100 Hours of Service Inspection

1. Suspension ride height (underside of frame to center line of axle) MUST BE WITHIN ± 0.25 " OF RECOMMENDED DESIGN HEIGHT. See page 8 for instructions on measuring ride height.

CAUTION An improperly set ride height could result in suspension component damage and/or poor vehicle ride performance.

2. After initial 5,000 miles (8,000 km) or 100 hours of service, inspect bolts and nuts at the pivot connections, transverse beam connections, and axle connections to assure they are properly torqued. Check all other nuts and bolts for proper torque. Retorque as necessary thereafter.
3. With vehicle on level surface and air pressure in excess of 100 psig (6.9 bars), all air springs should be of sufficient and equal firmness.

NOTE: Height control valves control all air springs. Check all fittings for air leaks, by applying a soapy water solution and checking for bubbles at all air connections and fittings.

Routine Maintenance – 50,000 Miles (80,000 km) or 1,000 Hours of Service or as Needed

At 50,000 miles or 1,000 hours of service, or when servicing vehicle brake system, inspect suspension components per 5,000 mile inspection. Also check all other suspension components for any sign of damage, looseness, wear or cracks. Replace any damaged parts to prevent equipment breakdown.

TORQUE SPECIFICATIONS

SIZE	ITEM	ADL TORQUE SPECIFICATIONS*	
		FT. LBS	NM
1/2" and 3/4"	Air Spring Nuts	30-35	41-48
5/8"	Control Rod Adj. Nut	85-95	115-129
3/4"	Shock Absorber	250-280	340-380
7/8"	Track Bar Nut	400-450	542-610
1" and 1 1/8"	Pivot Conn. Nut	800-850	1085-1153
1 1/8"	Axle Conn. Nut	800-850	1085-1153
1 1/8"	Transv. Beam Nuts	800-850	1085-1153

***NOTE:** Torque specifications listed above are with clean lubricated threads.

IMPORTANT: Use of special lubricants with friction modifiers, such as Anti-Seize or Never-Seize, without written approval from Holland Engineering, will void warranty and could lead to over torquing of fasteners or other component issues.

General Information

1. The torque specifications listed throughout the manual are applied to the nut, not the bolt.
2. Torque specifications: $\pm 5\%$ tolerance.
3. Lubricated Vs. Non-Lubricated Threads:

The torque specifications stated are for lubricated fasteners. Holland defines lubricated vs. non-lubricated as follows:

Lubricated.....a bolted connection, such as the pivot bolt/nut arrangement, that has a lubricant—like motor oil—pre-applied or applied to the thread surfaces, providing a lower torque requirement for a predetermined clampload.

Non-Lubricated.....a bolted connection, either new or in service, that has little or no lubricant on the thread surfaces. Typically, this applies to bolted connections that have been in service for a certain length of time where the original protective coating has evaporated or deteriorated due to environmental exposure. Thus, a “non-lube” torque specification is commonly required for in-service torque check or retorquing procedures. A “non-lube” specification could be required for new installations if the pivot bolt has seen sufficient shelf life to allow for evaporation and deterioration of the protective coating.

PRE-OPERATIONAL CHECKLIST

FIGURE 4

ADL-120 Components - Pre-Operational Checklist

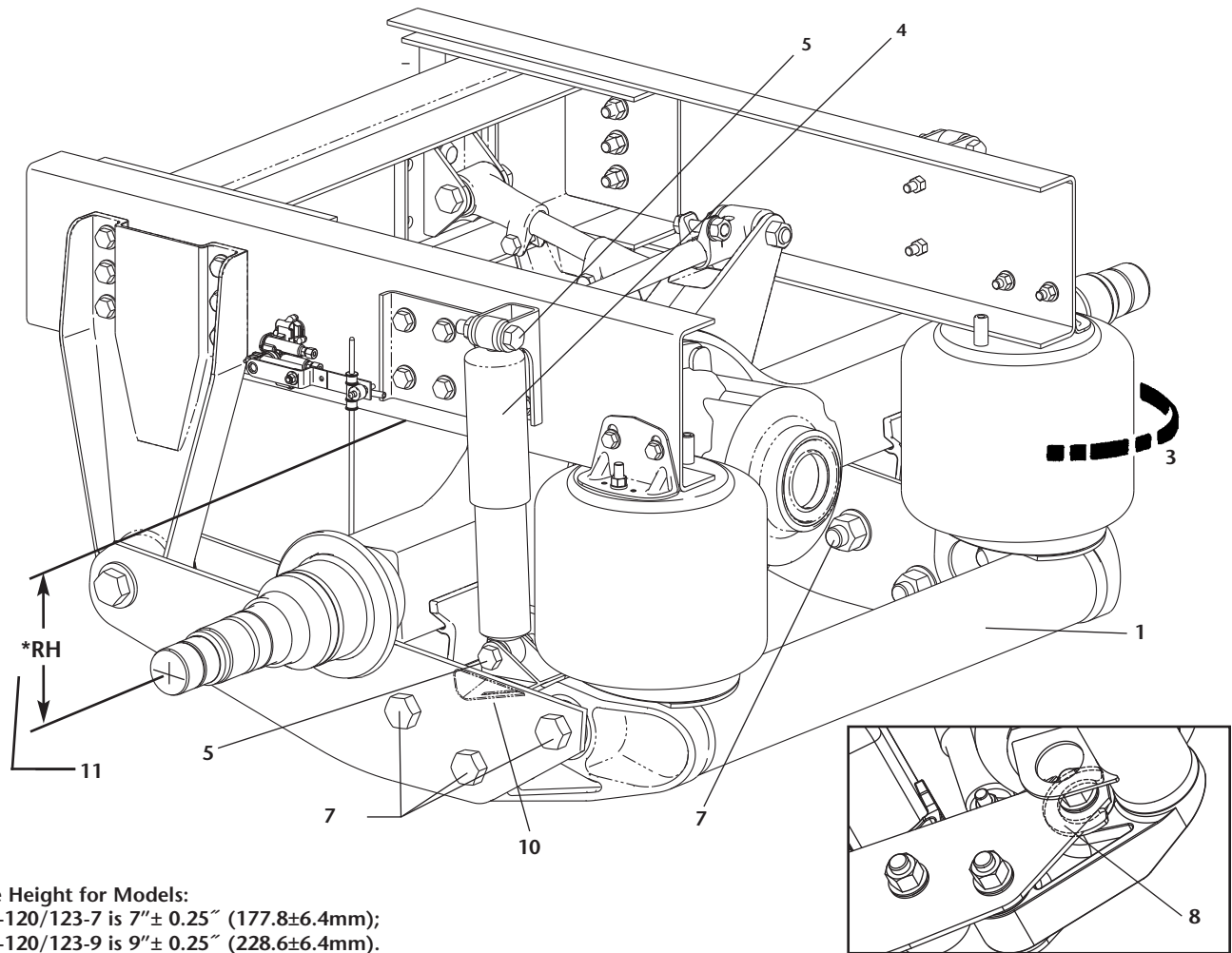

***Ride Height for Models:**
 ADL-120/123-7 is 7"± 0.25" (177.8±6.4mm);
 ADL-120/123-9 is 9"± 0.25" (228.6±6.4mm).

NOTE: Prior to placing unit in service, check the following items:

1. On page 4, write down the Serial Number and Parts List Number shown on the Serial Number Tag.
2. With the vehicle on a level surface, build the vehicle's air pressure above 100 psig (6.9 bars). With the vehicle shut off, check the system for air leaks and check all of the air springs for equal firmness.
3. Minimum clearance around air springs must be 3" (76.2mm).
4. Check the shock absorbers for proper installation (shock must be installed so shock dust cover is on top).
5. 3/4" shock absorber nuts must be torqued to the specification found in the Torque Specifications on page 5.

Re-torque Procedure – to retorque a connection, Holland recommends that the nut be loosened a couple of turns and then torqued to the recommended specification.

6. 1/2" air spring piston nuts must be torqued to the specification found in the Torque Specifications on page 5.
7. All 1 1/8" equalizing beam plate fasteners must be torqued to the specification found in the Torque Specifications on page 5; apply torque to nuts.
8. Check for proper installation of C-shape spacer washers at transverse beam and equalizing beam inner plate.
9. Check all frame fasteners per OEM recommended torque specification(s).
10. Check to ensure the debris shields are installed.
11. Suspension ride height should be within ±0.25" of recommended OEM design height. Reference the OEM's Height Control Valve adjustment procedure for proper ride height adjustment.
12. The pinion angle should be within OEM specifications (**FIGURE 10**, page 9).

ADL-120 PARTS LIST

FIGURE 5
ADL-120 Parts List

NOTE: Service parts should be ordered through the vehicle OEM or dealer Service Centers.

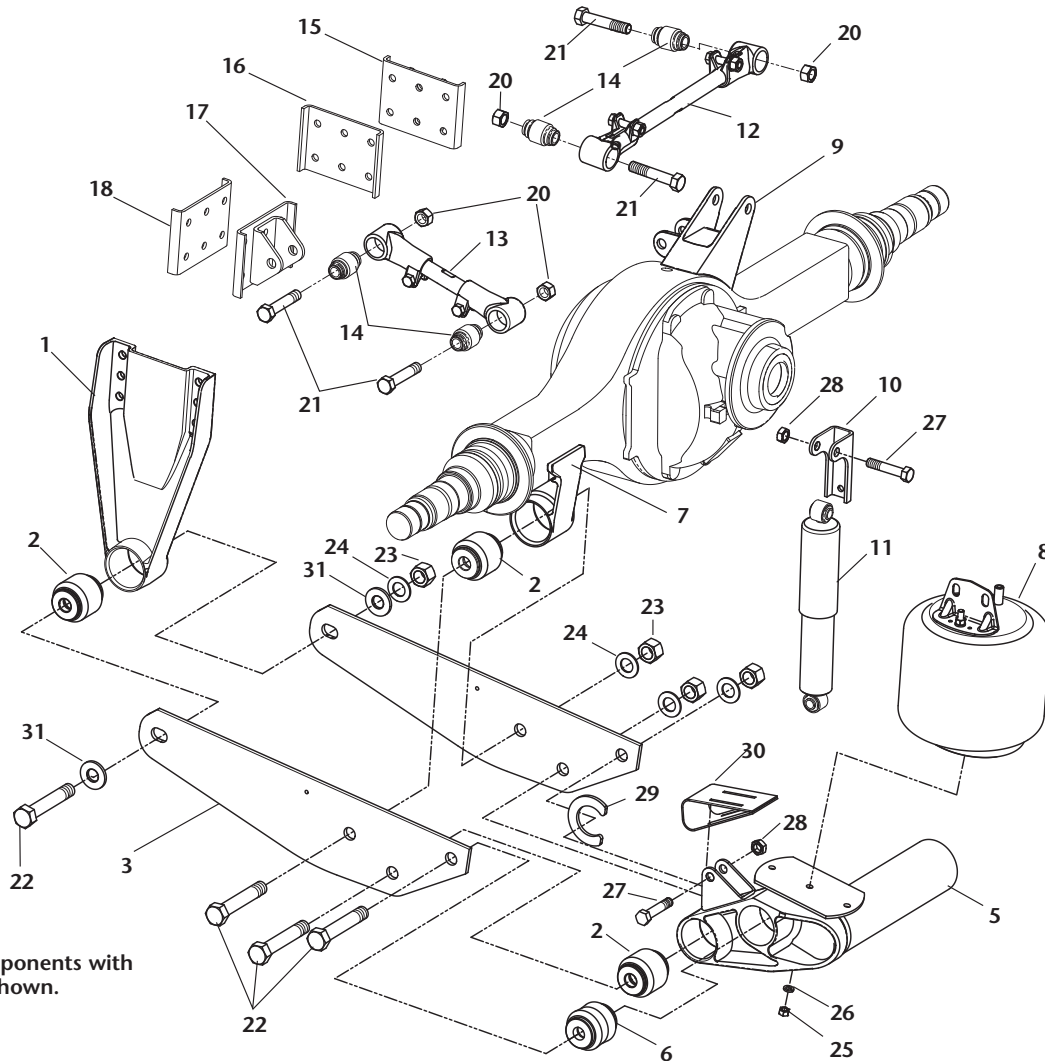

Suspension components with 7" ride height shown.

* Parts 1 and 17 change for 9" ride height. Refer to the OE/vehicle manufacturer's build specifications to properly identify the Holland Neway part numbers for the components noted by a single asterisk "**". A serial tag may be affixed to the transverse beam that also denotes the Holland Neway kit number that will provide the individual component numbers needed.

For disc brake compatible beams in Figure 3, item 3 is p/n 90034561**, item 4, is p/n 90034563†.

Item No.	Description	Part No.	Qty
1a	Frame Bracket Assembly - standard rail (shown)	*	2
1b	Frame Bracket Assembly - stacked rail (not shown)	*	2
2	Bushing - pivot, axle, front transverse beam	90008211	6
3	Equalizing Beam, adjustable	90015113**	2
4	Equalizing Beam, fixed (not shown)	90015115†	2
5a	Transverse Beam, for 34.0-34.12-inch frame rail width	90547733	1
5b	Transverse Beam, for 34.25-inch frame rail width	90547813	1
5c	Transverse Beam, for 34.62-inch frame rail width	90557736	1
6	Bushing, rear transverse beam	90008241	2
7	Axle Adapter	90501427	2
8	Air Spring	90557290	2
9	Control Arm Axle Bracket	90018670	1
10a	Shock Upper Bracket, for short frame rail	M0018031	2
10b	Shock Upper Bracket, for standard frame rail	90018542	2
11a	Shock Absorber, standard bus	90045443	2
11b	Shock Absorber for RV applications	Contact OEM	2
12	Track Bar, adjustable	90547801	1
13	Torque Rod, adjustable	90547800	1
14	Bushing - track bar and torque rod	90008243	4

Item No.	Description	Part No.	Qty
15	Bracket, track bar frame	90501439	1
16	Plate Reinforcement	90026068	1
17	Bracket, torque rod crossmember	90018658*	1
18	Plate Reinforcement for crossmember	90026068	1
19	Shim Adapter	90036251	2
20	Hex Lock Nut 0.875-9 GR C	93400498	4
21	Bracket, torque rod crossmember	93003833	4
22	Hex Bolt 1.125-7x6.5 GR 8	93004517	8
23	Hex Nut 1.125-7 GRC	93400506	8
24	Flat Washer, narrow 1.12	93600174	8
25	Hex Nut 0.5-13 GR B	93400136	2
26	Lock Washer 0.53	93600072	2
27	Hex Bolt 0.75-10x3.5 GR 8	93003599	4
28	Hex Lock Nut 0.75-10 GR C	93400494	4
29	C-Shape Spacer Washer	90036249	2
30	Debris Shield	90045456	2
31	Alignment Block	90008242	2

IMPORTANT: The part numbers listed may or may not correspond with your vehicle's ADL installation. Contact your vehicle OEM for part specification and ordering information.

SUSPENSION ADJUSTMENT INSTRUCTIONS

Ride Height

1. Before beginning to check the ride height, park the vehicle on a level floor. Block the front tires to prevent the vehicle from rolling forward or backward.

⚠ WARNING Always chock tires to prevent rollaway—serious injury or death may occur.

2. Pressurize the air system with a constant supply of air in excess of 100 psig (6.9 bars). All air springs should inflate and locate suspension at proper ride height.

IMPORTANT: The specified ride height for the ADL-120-7 Model is 7.0" (178mm, **FIGURE 6**).

3. If ride height is not within $\pm 0.25"$ (6mm) of the specified ride height, adjust the height control valve in accordance with the instructions in Height Control Valve Manual or the OEM's manual. To accurately measure ride height, perform steps 4 - 6 (**FIGURE 6**).
4. Measure the distance from the bottom of the frame rail to the ground (**FIGURE 6**).
5. Measure the distance from the center of the wheel to the ground (**FIGURE 6**).
6. To determine ride height, subtract the value measured in step 5 from the value measured in step 4.

EXAMPLE: The bottom of the frame rail to the ground measures 27.5" (699mm) (**A**); the center of the wheel to the ground measures 20.5" (521mm) (**B**).

A - B = RIDE HEIGHT, therefore:
27.5" minus 20.5" = 7.0" (178mm)
RIDE HEIGHT is 7.0" (178mm)

7. If ride height is out of specification, see the Height Control Valve manual for instructions on how to adjust.

FIGURE 6
ADL-120 Ride Height

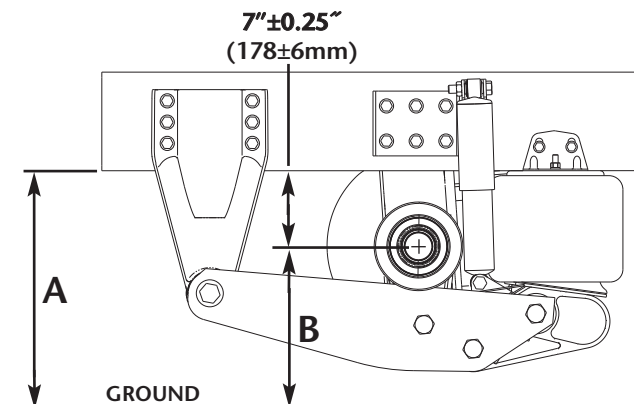

Axle Alignment

1. The vehicle must be on a level floor and unloaded. Block the front tires to prevent the vehicle from rolling forward or backward.

⚠ WARNING Always chock tires to prevent rollaway—serious injury or death may occur.

2. Support the frame with jack stands and then completely exhaust air from the air springs by disconnecting air supply line from air spring.

⚠ WARNING Always use jack stands of sufficient strength and position them according to OEM recommendations. Failure to do so may cause vehicle to fall causing vehicle damage and/or serious personal injury.

3. Remove the pivot bolt from the side that has alignment blocks welded to the equalizing beam plates (**FIGURE 7**).
4. Grind off the welds attaching the alignment blocks to the equalizing beam plates being especially careful not to grind off equalizing beam plate material (**FIGURE 7**).

⚠ WARNING Never remove parent material from an equalizing beam plate when grinding to remove the alignment block. If parent material is removed—weakening the plate—always replace the equalizing beam plate with a new plate.

FIGURE 7
Alignment Block Welded to Equalizing Beam

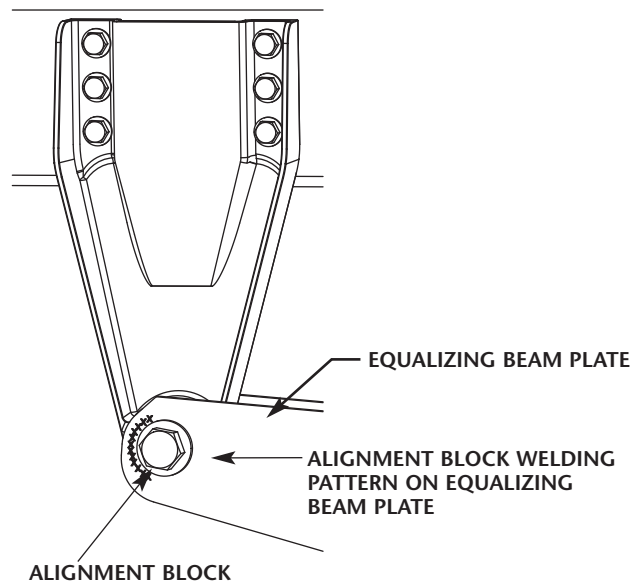

SUSPENSION ADJUSTMENT INSTRUCTIONS *continued*

Axle Alignment *continued*

5. Replace pivot bolt, alignment blocks, hardened washer, and nut with new hardware. Tighten all hardware so that all components are secure, but **DO NOT** tighten to torque specifications.
6. Align the axle per the OEM's recommendation (**FIGURE 8**).

IMPORTANT: Holland recommends that the chassis be set at the specified ride height of $\pm 0.25"$ ($178 \pm 6\text{mm}$) prior to axle alignment.

FIGURE 8
Adjusting Alignment Block Prior to Welding

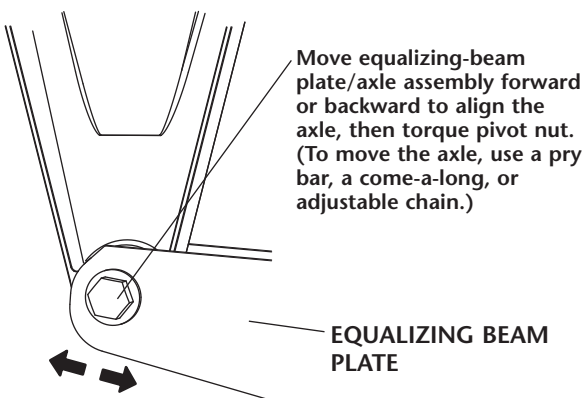

7. Torque the pivot connection nut (see Torque Specifications on page 5).
8. Recheck the alignment, and weld the alignment blocks to the equalizing beam plates (**FIGURE 9**).

FIGURE 9
Alignment Block Welded in Place

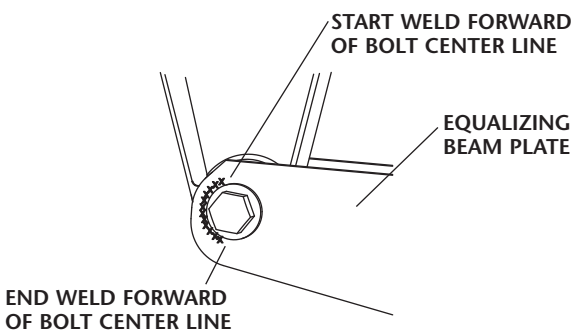

9. After the alignment blocks have cooled, retorque the pivot connection (see Torque Specifications on page 5).

IMPORTANT: A minimum 3-minute cool down period is required after welding connection before reapplying torque to the pivot nut.

Pinion Angle Adjustment

IMPORTANT: Pinion angle must be checked with the vehicle at ride height (**FIGURE 6**).

1. If pinion angle is not within the OEM specification, it can be adjusted by changing the length of the torque rod (**FIGURE 10**).

IMPORTANT: Adjusting the pinion angle will change the ride height. Ride height should be rechecked after pinion angle is adjusted.

2. Loosen both adjustment nuts on the torque rod (**FIGURE 10**).

FIGURE 10
Pinion Angle Adjustment

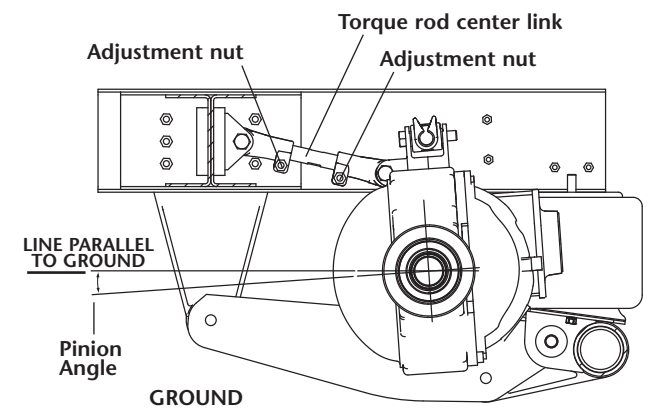

3. If torque rod center link has wrench flats, turn the center link using a $1\frac{9}{16}"$ (39.9mm) wrench—or using a pipe wrench.
4. After the pinion angle is within OEM specifications, tighten the two adjustment nuts (see Torque Specifications on page 5).
5. After pinion angle adjustment angle is completed, the ride height must be checked for proper setting. If specification is exceeded, see "Ride Height" procedure on page 8.

SERVICE REPAIR KITS

NOTE: Each Service Repair Kit contains enough parts to repair both sides of the suspension.

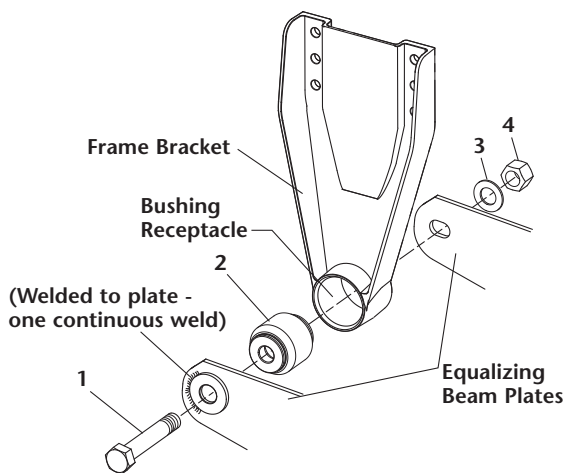

Pivot Connection

SRK-514 – Holland part number: 481 00 378

ITEM	PART NO.	DESCRIPTION	QTY.
1	930 04 517	Hex Bolt 1.13"-7x6.5 GR 8	2
2	900 08 211	Bushing	2
3	936 00 174	Washer Flat Narrow 1.12"	2
4	934 00 506	Hex Nut 1.125"-7 GR C	2

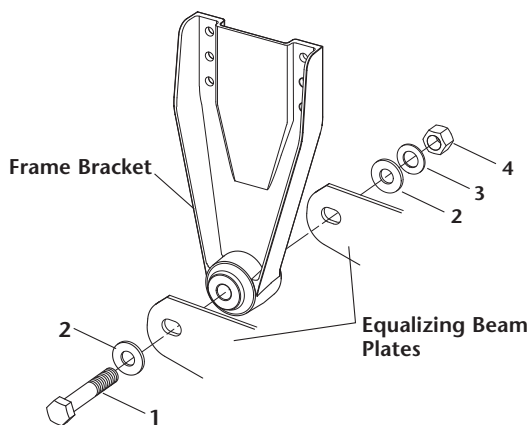

Pivot Connection Alignment Block

SRK-518 – Holland part number: 481 00 482

ITEM	PART NO.	DESCRIPTION	QTY.
1	930 04 517	Hex Bolt 1.13"-7x6.5 GR 8	2
2	900 08 242	Alignment Block	2
3	936 00 174	Washer Flat Narrow 1.12"	2
4	934 00 506	Hex Nut 1.125"-7 GR C	2

One side is adjustable and one side is fixed.

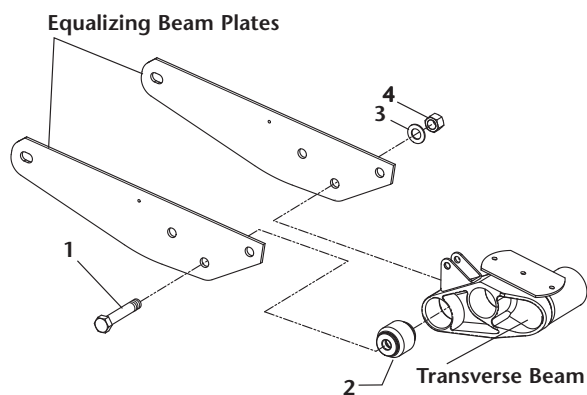

ADL-120 Front Transverse Beam Connection

SRK-514 – Holland part number: 481 00 378

Straight Blade

ITEM	PART NO.	DESCRIPTION	QTY.
1	930 04 517	Hex Bolt 1.13"-7x6.5 GR 8	2
2	900 08 211	Bushing	2
3	936 00 174	Washer Flat Narrow 1.12"	2
4	934 00 506	Hex Nut 1.125"-7 GR C	2

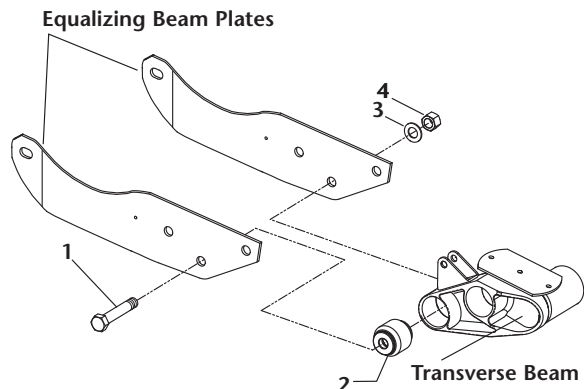

ADL-123 Front Transverse Beam Connection

SRK-514 – Holland part number: 481 00 378

Disc Brake Compatible Beams

ITEM	PART NO.	DESCRIPTION	QTY.
1	930 04 517	Hex Bolt 1.13"-7x6.5 GR 8	2
2	900 08 211	Bushing	2
3	936 00 174	Washer Flat Narrow 1.12"	2
4	934 00 506	Hex Nut 1.125"-7 GR C	2

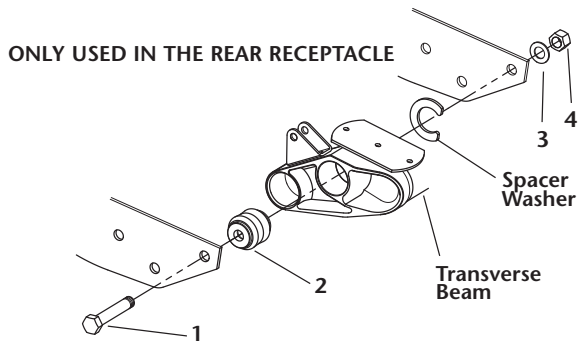

Rear Transverse Beam Connection

SRK-515 – Holland part number: 481 00 379

ITEM	PART NO.	DESCRIPTION	QTY.
1	930 04 517	Hex Bolt 1.13"-7x6.5 GR 8	2
2	900 08 241	Bushing	2
3	936 00 174	Washer Flat Narrow 1.12"	2
4	934 00 506	Hex Nut 1.125"-7 GR C	2

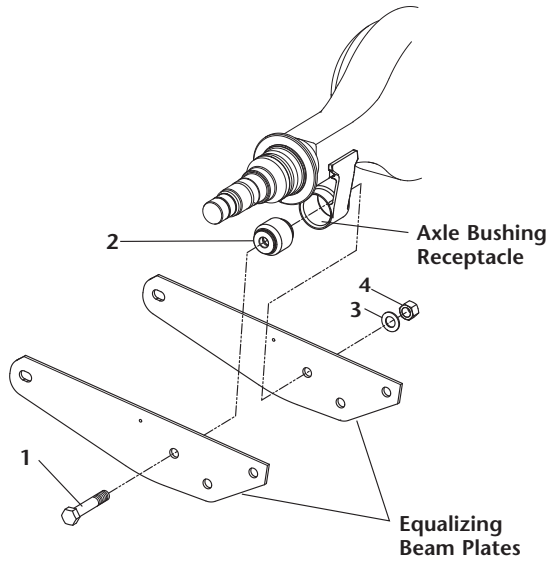

Axle Connection

SRK-514 – Holland part number: 481 00 378

ITEM	PART NO.	DESCRIPTION	QTY.
1	930 04 517	Hex Bolt 1.13"-7x6.5 GR 8	2
2	900 08 211	Bushing	2
3	936 00 174	Washer Flat Narrow 1.12"	2
4	934 00 506	Hex Nut 1.125"-7 GR C	2

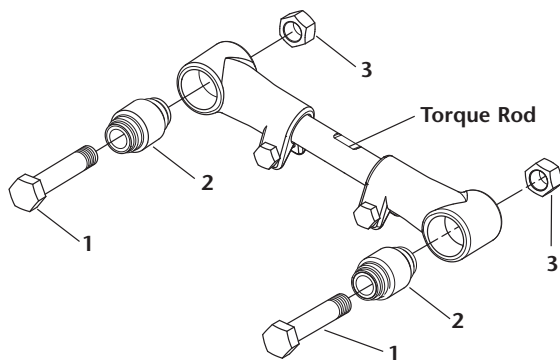

Torque Rod and Track Bar Bushing

SRK-517 – Holland part number: 481 00 481

ITEM	PART NO.	DESCRIPTION	QTY.
1	930 03 845	Hex Bolt 0.875"-9x5 GR 8	2
2	900 08 243	Bushing	2
3	934 00 498	Hex Nut 0.875"-9 GR C	2

PART REPLACEMENT INSTRUCTIONS

Suspension Air Springs

IMPORTANT: Air springs must be replaced with the proper air spring for your vehicle installation. Check the flexible member and piston for the part number. If the part number is unidentifiable, contact your vehicle OEM for assistance.

1. The vehicle must be on a level floor and unloaded. Block the front tires to prevent the vehicle from rolling forward or backward.

⚠ WARNING Always chock tires to prevent rollaway—serious injury or death may occur.

2. Support the frame with jack stands.

⚠ WARNING Always use jack stands of sufficient strength and position them according to OEM recommendations. Failure to do so may cause vehicle to fall causing vehicle damage and/or serious personal injury.

3. Exhaust air from the suspension system by:
 - Height Control Valve - disconnect the link from lower connection (**FIGURE 11B**) and pull down on the link, or

NOTE: Holland recommends referring to the Height Control Valve Manual for the correct procedure.

- Disconnect air supply line from the air spring.

NOTE: If air spring has a leak and is deflated, Step 3 still must be performed.

4. Disconnect and remove the old air spring assembly (**FIGURE 11A**).
5. Install the new air spring assembly, and properly torque the piston fastener (see Torque Specifications on page 5).
6. Torque the frame fasteners per the OEM recommended torque specification.
7. Reconnect the air supply line and height control valve lower-link connection (**FIGURE 11B**).
8. Remove the jack stands.
9. Increase suspension air system reservoir pressure in excess of 100 psig (6.9 bars). Check for leaks. All air springs should inflate and locate suspension at proper ride height.

⚠ CAUTION While vehicle air system pressure capabilities may be in excess of 120 psig (8.3 bars), the air spring pressure must not be set above 100 psig (6.9 bars) or the rubber air spring can tear or fracture.

10. Check ride height to make sure it is within ± 0.25 " of specification.
11. If ride height adjustment is necessary, refer to page 8 for adjustment procedure.

FIGURE 11A
Air Spring Replacement

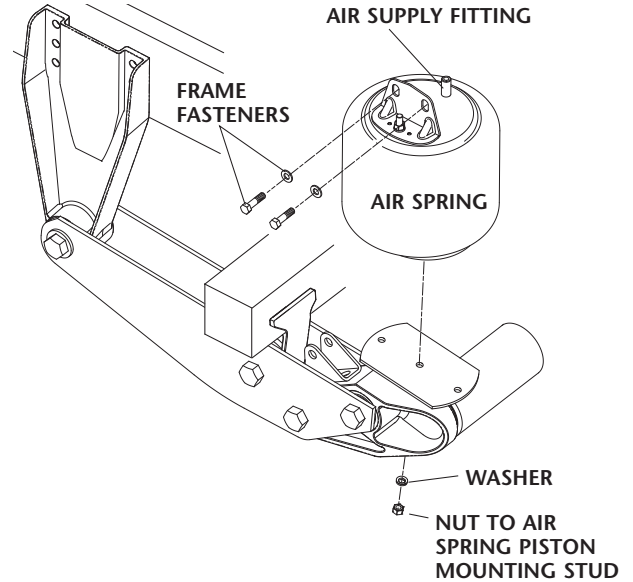
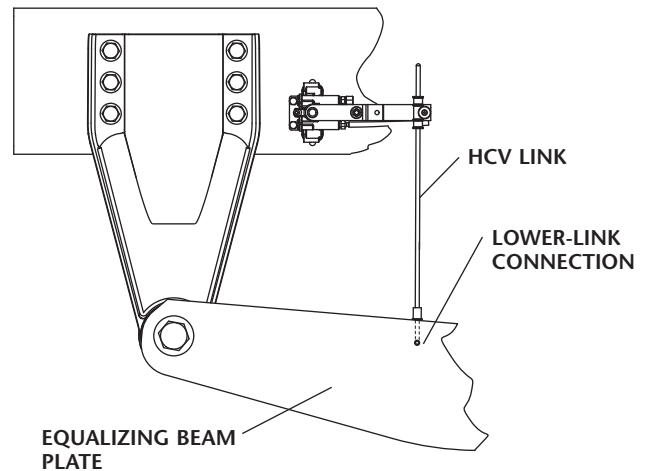

FIGURE 11B
HCV Linkage



Axle Adapter Bushing

NOTE: Because the axle adapter is welded to the axle, a Holland Bushing Service Tool, Part No. 505 44 012 (FIGURE 12), is available to ease removal and replacement of bushings. Contact your OEM Service Center for details.

FIGURE 12

Bushing Service Tool

The bushing service tool can be used on all ADL bushings, including pivot connections and transverse beam connections.

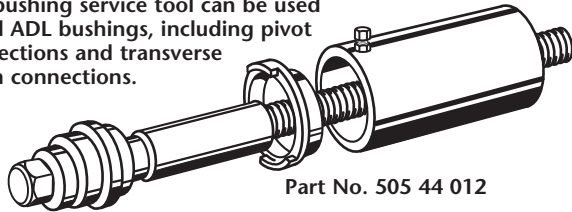

Part No. 505 44 012

1. The vehicle must be on a level floor and unloaded. Block the front tires to prevent the vehicle from rolling forward or backward.

⚠ WARNING Always chock tires to prevent rollaway—serious injury or death may occur.

2. Jack up the rear of the vehicle using jack points and procedure provided in vehicle maintenance manual.
3. Support the frame with jack stands.

⚠ WARNING Always use jack stands of sufficient strength and position them according to OEM recommendations. Failure to do so may cause vehicle to fall causing vehicle damage and/or serious personal injury.

4. Remove the tires.
5. Using a floor jack, support the axle at the axle bowl.
6. Using another floor jack, support the transverse beam.
7. Exhaust air from the suspension system by:
 - Height Control Valve - disconnect the link from lower connection (FIGURE 11B) and pull down on the link, or

NOTE: Holland recommends referring to the Height Control Valve Manual for the correct procedure.

- Disconnect air supply line from the air spring.

NOTE: If air spring has a leak and is deflated, Step 7 still must be performed.

8. Disconnect the shock absorbers and air springs at their lower connections.

9. Remove the axle adapter connection hardware on both sides of the equalizing beam (FIGURE 13) — transverse beam must be supported by floor jack before disconnection.
10. Using the floor jack, support and slowly lower the equalizing beam/transverse beam assembly, providing access to the axle adapter bushings.

NOTE: If equalizing beam plates are too snug on axle adapter, it may be necessary to loosen the transverse beam connection hardware on both sides.

11. Using a Bushing Service Tool, Part No. 505 44 012, press out old axle adapter bushings.

IMPORTANT: DO NOT use an open flame or other heat source to remove the bushings.

12. Clean out all foreign material from axle adapter bushing receptacles.

FIGURE 13

Axle Adapter Bushing Replacement

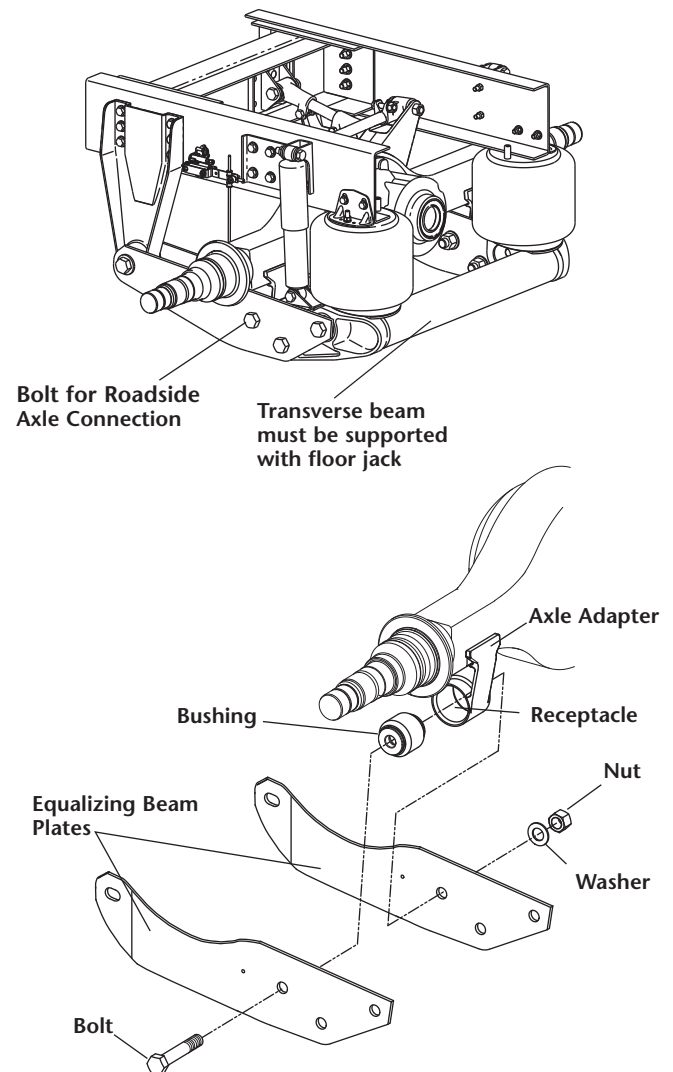

continued

Axle Adapter Bushing *continued*

13. Inspect the axle adapters, their welds, and other parts for cracks or failed welds. If cracks are detected anywhere on an axle adapter, replace the adapter.

⚠ WARNING Never repair a cracked axle adapter. DO NOT weld cracks. Secondary weld failures during use may cause loss of vehicle control and could cause serious injury or death.

14. Lubricate the new replacement bushings and bushing receptacles with an approved rubber lubricant or a soap and water solution.

IMPORTANT: DO NOT use oil-based lubricant or brake fluid, as it can cause damage to the rubber.

15. Use the Bushing Service Tool to press the new bushings into the axle adapter receptacles (**FIGURE 13**).

NOTE: Bushing must be centered in axle adapter receptacle.

16. Using the floor jack, raise the transverse beam assembly to its original position. Reassemble with new hardware, and torque all the axle adapter and transverse beam nuts (see Torque Specifications on page 5). Remove the floor jack supporting transverse beam.

IMPORTANT: Suspension should be close to ride height when torquing the axle adapter connection to avoid bushing windup. (Axle bowl can be supported by floor jack: DO NOT raise rear of vehicle.)

17. Reconnect the air springs, shocks, and height control valve link, and torque all hardware (see Torque Specifications on page 5).
18. Remove the floor jack supporting the axle bowl.
19. Reinstall the tires. Remove jack stands, lower vehicle, and remove floor jack.
20. Increase suspension air system reservoir pressure in excess of 100 psig (6.9 bars). Check for leaks. All air springs should inflate and locate suspension at proper ride height.

While vehicle air system pressure capabilities may be in **CAUTION** excess of 120 psig (8.3 bars), the air spring pressure must not be set above 100 psig (6.9 bars) or the rubber air spring can tear or fracture.

21. Check ride height to make sure it is within ± 0.25 " (6mm) of specification.
22. If ride height adjustment is necessary, refer to page 8 for adjustment procedure.

Frame Bracket Pivot Bushing

NOTE: A Holland Bushing Service Tool is available to ease removal and replacement of bushings (**FIGURE 12**). Contact your OEM Service Center for details.

IMPORTANT: At time of service, replace both bushings.

1. The vehicle must be on a level floor and unloaded. Block the front tires to prevent the vehicle from rolling forward or backward.

⚠ WARNING Always chock tires to prevent rollaway—serious injury or death may occur.

2. Jack up the rear of the vehicle using jack points and procedure provided in vehicle maintenance manual.
3. Support the frame with jack stands.

⚠ WARNING Always use jack stands of sufficient strength and position them according to OEM recommendations. Failure to do so may cause vehicle to fall causing vehicle damage and/or serious personal injury.

4. Remove the tires.
5. Using a floor jack, support the axle at the axle bowl.
6. Exhaust air from the suspension system by:
 - Height Control Valve - disconnect the link from lower connection (**FIGURE 11B**) and pull down on the link, or

NOTE: Holland recommends referring to the Height Control Valve Manual for the correct procedure.

- Disconnect air supply line from the air spring.

NOTE: If air spring has a leak and is deflated, Step 6 still must be performed.

7. Disconnect the shock absorbers and air springs at their lower connections.
8. Remove the pivot connection hardware (**FIGURE 14**).

FIGURE 14
Frame Bracket Pivot Bushing Replacement

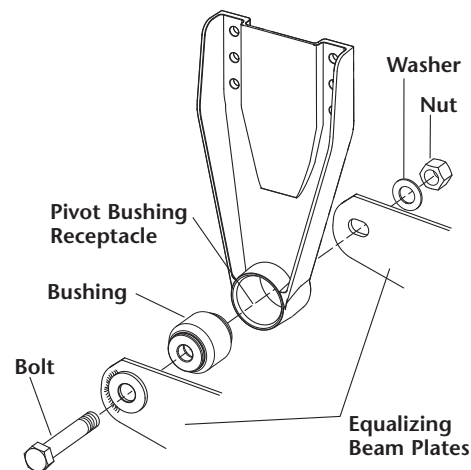

continued

Frame Bracket Pivot Bushing *continued*

- Using the floor jack supporting the axle bowl, lower the axle and suspension to enable access to the frame bracket pivot bushings.
- Use the Bushing Service Tool to press out old frame bracket pivot bushings.

IMPORTANT: DO NOT use an open flame or other heat source to remove the bushings.

- Clean out all foreign material from frame bracket pivot bushing receptacle(s).
- Inspect the frame brackets for cracks. If cracks are detected anywhere on a frame bracket, replace the bracket.

WARNING Never repair a cracked frame bracket. DO NOT weld cracks. Secondary weld failures during use may cause loss of vehicle control and could cause serious injury or death.

- Lubricate the new replacement bushings and bushing receptacles with an approved rubber lubricant or a soap and water solution.

IMPORTANT: DO NOT use oil-based lubricant or brake fluid, as it can cause damage to the rubber.

- Use the Bushing Service Tool to press the new bushings into the proper receptacles.

NOTE: Bushings must be centered in frame bracket receptacle.

- Reassemble pivot connection, and raise the axle and suspension to its original position.

CAUTION DO NOT lift the vehicle off the jack stands.

Align the holes from the equalizing beams with the holes from the pivot bushings, and replace the pivot hardware.

- Torque the pivot connection nuts (see Torque Specifications on page 5).

IMPORTANT: Suspension should be close to ride height when torquing the front pivot connection to avoid bushing windup. (Axle bowl can be supported by floor jack; DO NOT raise rear of vehicle.)

- Reconnect the air springs, shocks, and height control valve link, and torque all hardware (see Torque Specifications on page 5).
- Reinstall the tires. Remove jack stands, lower vehicle, and remove floor jack supporting the transverse beam.
- Increase suspension air system reservoir pressure in excess of 100 psig (6.9 bars). Check for leaks. All air springs should inflate and locate suspension at proper ride height.

CAUTION While vehicle air system pressure capabilities may be in excess of 120 psig (8.3 bars), the air spring pressure must not be set above 100 psig (6.9 bars) or the rubber air spring can tear or fracture.

- Check ride height to make sure it is within ± 0.25 " (6mm) of specification.
- If ride height adjustment is necessary, refer to page 8 for adjustment procedure.

Transverse Beam Bushing

NOTE: A Holland Bushing Service Tool is available to ease removal and replacement of bushings (FIGURE 12). Contact your OEM Service Center for details.

- The vehicle must be on a level floor and unloaded. Block the front tires to prevent the vehicle from rolling forward or backward.

WARNING Always chock tires to prevent rollaway—serious injury or death could occur.

- Jack up the rear of the vehicle using jack points and procedure provided in vehicle maintenance manual.
- Support the frame with jack stands.

WARNING Always use jack stands of sufficient strength and position them according to OEM recommendations. Failure to do so may cause vehicle to fall causing vehicle damage and/or serious personal injury.

- Remove the tires.
- Using a floor jack, support the axle at the axle bowl.
- Using another floor jack, support the transverse beam.
- Exhaust air from the suspension system by:
 - Height Control Valve - disconnect the link from lower connection (FIGURE 11B) and pull down on the link, or

NOTE: Holland recommends referring to the Height Control Valve Manual for the correct procedure.

- Disconnect air supply line from the air spring.

NOTE: If air spring has a leak and is deflated, Step 7 still must be performed.

- Disconnect the shock absorbers and air springs at their lower connections.
- Remove the transverse beam connection hardware on both sides (FIGURE 15).

FIGURE 15
Transverse Beam Bushing Replacement

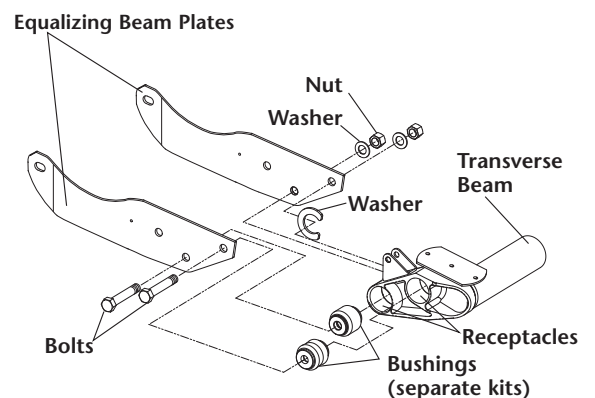

continued

PART REPLACEMENT INSTRUCTIONS *continued*

Transverse Beam Bushing *continued*

- Using the floor jack, support and lower the transverse beam, providing access to the transverse beam bushings.

NOTE: The axle adapter hardware connecting the equalizing beam plates to the axle adapter may need to be loosened on both sides.

- Use the Bushing Service Tool to press out the old transverse beam bushings.

IMPORTANT: **DO NOT** use an open flame or other heat source to remove the bushings.

- Clean out all foreign material from transverse beam bushing receptacles.
- Inspect the transverse beam for any cracks or failed welds. If cracks are detected anywhere on the beam, replace the beam.

WARNING Never repair a cracked transverse beam. **DO NOT** weld cracks.

Secondary weld failures during use may cause loss of vehicle control and could cause serious injury or death.

- Lubricate the new replacement bushings and bushing receptacles with an approved rubber lubricant or a soap and water solution.

IMPORTANT: **DO NOT** use oil-based lubricant or brake fluid, as it can cause damage to the rubber.

- Use the Bushing Service Tool to press the new bushings into the transverse beam receptacles.

NOTE: Bushings must be centered in the transverse beam receptacle.

- Raise the transverse beam assembly to its original position. Reassemble with new hardware, and torque all the transverse beam nuts (see Torque Specifications on page 5).
- Reconnect the air springs, shocks, and height control valve link, and torque all hardware (see Torque Specifications on page 5).
- Remove the floor jack supporting the axle bowl.
- Reinstall the tires. Remove jack stands, lower vehicle, and remove floor jack supporting the transverse beam.
- Increase suspension air system reservoir pressure in excess of 100 psig (6.9 bars). Check for leaks. All air springs should inflate and locate suspension at proper ride height.

CAUTION While vehicle air system pressure capabilities may be in excess of 120 psig (8.3 bars), the air spring pressure must not be set above 100 psig (6.9 bars) or the rubber air spring can tear or fracture.

- Check ride height to make sure it is within $\pm 0.25"$ (6mm) of specification.
- If ride height adjustment is necessary, refer to page 8 for adjustment procedure.

Shock Absorbers

- The vehicle must be on a level floor and unloaded. Block the front tires to prevent the vehicle from rolling forward or backward.

WARNING Always chock tires to prevent rollaway—serious injury or death could occur.

- Jack up the rear of the vehicle using jack points and procedure provided in vehicle maintenance manual.
- Support the frame with jack stands.

WARNING Always use jack stands of sufficient strength and position them according to OEM recommendations. Failure to do so may cause vehicle to fall causing vehicle damage and/or serious personal injury.

- Remove the tires.
- Using a floor jack, support the axle at the axle bowl.
- Exhaust air from the suspension system by:
 - Height Control Valve - disconnect the link from lower connection (**FIGURE 11B**) and pull down on the link, or

NOTE: Holland recommends referring to the Height Control Valve Manual for the correct procedure.

- Disconnect air supply line from the air spring.

NOTE: If air spring has a leak and is deflated, Step 6 still must be performed.

- Remove upper and lower mounting hardware and shock absorber (**FIGURE 16**).

NOTE: Inspect space within or above debris shield (below lower loop of shock), and remove rocks that may be lodged in this space.

- Replace with correct shock absorber. Shock orientation is with the dust cover near the top mounting bolt (**FIGURE 16**).
- Torque fasteners (see Torque Specifications on page 5).

FIGURE 16

Shock Replacement

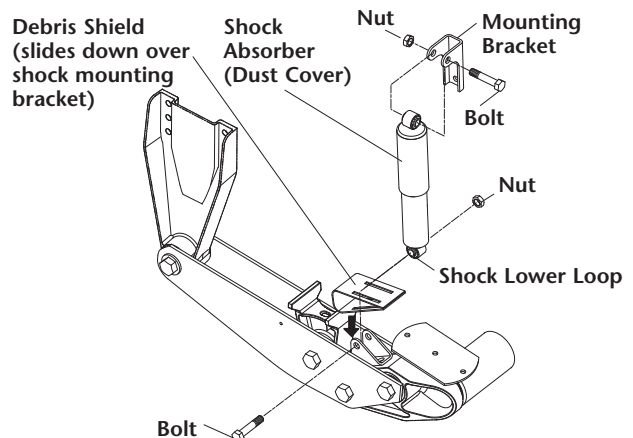

Torque Rod

1. The vehicle must be on a level floor and unloaded.
Block the front tires to prevent the vehicle from rolling forward or backward.

⚠️ WARNING Always chock tires to prevent rollaway—serious injury or death could occur.

2. Jack up the rear of the vehicle using jack points and procedure provided in OEM's vehicle maintenance manual.
3. Support the frame with jack stands.

⚠️ WARNING Always use jack stands of sufficient strength and position them according to OEM recommendations. Failure to do so may cause vehicle to fall causing vehicle damage and/or serious personal injury.

4. Remove the tires.
5. Using a floor jack, support the axle at the axle bowl.
6. Exhaust air from the suspension system by:
 - Height Control Valve - disconnect the link from lower connection (**FIGURE 11B**) and pull down on the link, or

NOTE: Holland recommends referring to the Height Control Valve Manual for the correct procedure.

- Disconnect air supply line from the air spring.

NOTE: If air spring has a leak and is deflated, Step 6 still must be performed.

7. Disconnect the shock absorbers and air springs at their lower connections.
8. With the floor jack supporting the axle bowl, lower the suspension and axle to enable access to the torque rod.
9. Secure the axle so the axle will not move when the torque rod is removed.

IMPORTANT: First, place a solid 1³/₄" square spacer block between the axle adapter and the lower shock bracket to prevent axle from moving backwards. Second, loop and tie a chain around the axle and transverse beam to prevent axle from moving forwards.

⚠️ WARNING Axle must not move—or personal injury may occur.

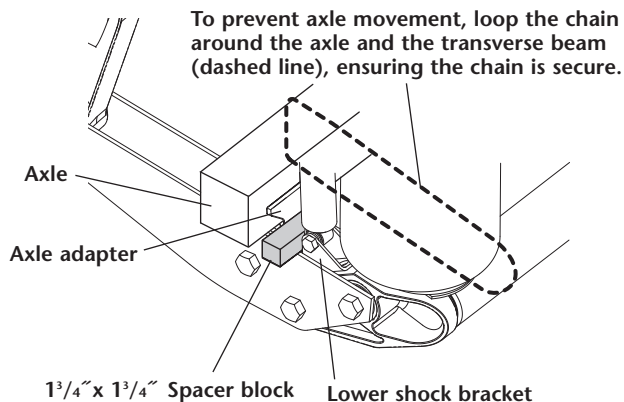
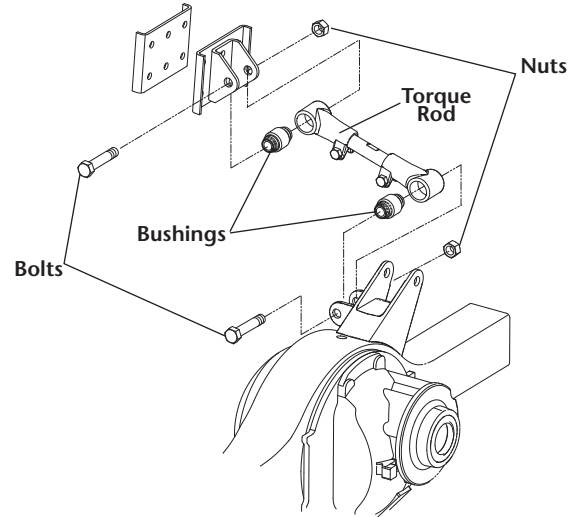

FIGURE 17
Torque Rod Replacement

⚠️ WARNING Always secure axle (see Step 9). Failure to secure axle could cause the axle to move in either direction, which may result in serious personal injury.



10. Remove the torque rod connection hardware (**FIGURE 17**).
11. Using a hydraulic press capable of 10,000 lbs. of force, press out the old bushings from the torque rod ends.

⚠️ WARNING The torque rod support fixture must be securely mounted to the hydraulic press; otherwise, the torque rod may abruptly shift and personal injury could occur.

IMPORTANT: DO NOT use an open flame or other heat source to remove the bushings.

12. Clean out all foreign material from torque rod bushing receptacles.
13. Lubricate the replacement bushings and bushing receptacles with an approved rubber lubricant or a soap and water solution.

IMPORTANT: DO NOT use oil-based lubricant or brake fluid, as it can cause damage to the rubber.

14. Press in the new torque rod bushings.

NOTE: Bushings must be centered in the torque rod end receptacles.

15. Reattach the torque rod using new hardware, and torque fasteners (see Torque Specifications on page 5).
16. With the floor jack supporting the axle bowl, raise the axle/suspension to its original position. Reconnect the air springs, shocks, and height control valve link, and torque all hardware (see Torque Specifications on page 5).

IMPORTANT: Suspension should be close to ride height when torquing the torque rod connections to avoid bushing windup. (Axle bowl can be supported by floor jack: **DO NOT** raise rear of vehicle.)

continued

PART REPLACEMENT INSTRUCTIONS *continued*

Torque Rod *continued*

17. Reinstall the tires. Remove jack stands, lower vehicle, and remove floor jack.
18. Increase suspension air system reservoir pressure in excess of 100 psig (6.9 bars). Check for leaks. All air springs should inflate and locate suspension at proper ride height.

CAUTION While vehicle air system pressure capabilities may be in excess of 120 psig (8.3 bars), the air spring pressure must not be set above 100 psig (6.9 bars) or the rubber air spring can tear or fracture.

19. Check ride height to make sure it is within ± 0.25 " (6mm) of specification.
20. If ride height adjustment is necessary, refer to page 8 for adjustment procedure.
21. Compare the pinion angle to the OEM specification.
22. If it is necessary to adjust the pinion angle, refer to page 9.

Track Bar

1. The vehicle must be on a level floor and unloaded. Block the front tires to prevent the vehicle from rolling forward or backward.

WARNING Always chock tires to prevent rollaway—serious injury or death could occur.

2. Jack up the rear of the vehicle using jack points and procedure provided in vehicle maintenance manual.
3. Support the frame with jack stands.

WARNING Always use jack stands of sufficient strength and position them according to OEM recommendations. Failure to do so may cause vehicle to fall causing vehicle damage and/or serious personal injury.

4. Remove the tires.
5. Using a floor jack, support the axle at the axle bowl.
6. Exhaust air from the suspension system by:
 - Height Control Valve - disconnect the link from lower connection (**FIGURE 11B**) and pull down on the link, or

NOTE: Holland recommends referring to the Height Control Valve Manual for the correct procedure.

- Disconnect air supply line from the air spring.

NOTE: If air spring has a leak and is deflated, Step 6 still must be performed.

7. Disconnect the shock absorbers and air springs at their lower connections.
8. Using the floor jack, support and lower the axle and suspension to enable access to the track bar.
9. Remove the track bar connection hardware (**FIGURE 18**).
10. Using a hydraulic press capable of 10,000 lbs. of force, press out the old bushings from the track bar ends.

CAUTION The track bar support fixture must be securely mounted to the hydraulic press; otherwise, the track bar may abruptly shift and personal injury could occur.

IMPORTANT: DO NOT use an open flame or other heat source to remove the bushings.

11. Clean out all foreign material from track bar bushing receptacles.

FIGURE 18
Track Bar Replacement

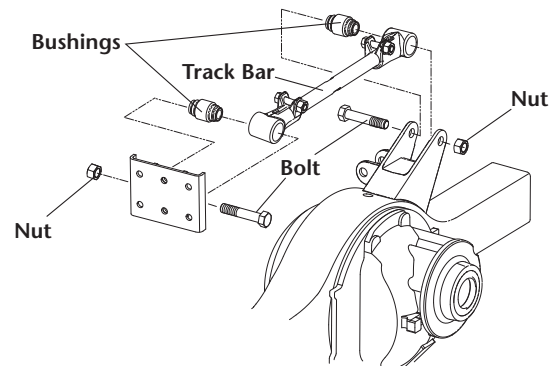

12. Lubricate the replacement bushings and bushing receptacles with an approved rubber lubricant or a soap and water solution.

IMPORTANT: DO NOT use oil-based lubricant or brake fluid, as it can cause damage to the rubber.

13. Press in the new bushings.

NOTE: Bushings must be centered in the track bar receptacles.

14. Reattach the track bar using new hardware, and torque fasteners (see Torque Specifications on page 5).
15. With the floor jack supporting the axle bowl, raise the axle/suspension to its original position. Reconnect the air springs, shocks, and height control valve link, and torque all hardware (see Torque Specifications on page 5).

IMPORTANT: Suspension should be close to ride height when torquing the track bar connections to avoid bushing windup. (Axle bowl can be supported by floor jack: DO NOT raise rear of vehicle.)

16. Reinstall the tires. Remove jack stands, lower vehicle, and remove floor jack.
17. Increase suspension air system reservoir pressure in excess of 100 psig (6.9 bars). Check for leaks. All air springs should inflate and locate suspension at proper ride height.

CAUTION While vehicle air system pressure capabilities may be in excess of 120 psig (8.3 bars), the air spring pressure must not be set above 100 psig (6.9 bars) or the rubber air spring can tear or fracture.

18. Check ride height to make sure it is within ± 0.25 " (6mm) of specification.
19. If ride height adjustment is necessary, refer to page 8 for adjustment procedure.

TROUBLESHOOTING

Problem	Possible Cause and Remedy
All air springs flat (no air).	<p>Insufficient air pressure in the vehicle air system. Check the air pressure gauge on instrument panel. If air pressure is low, run the engine until a minimum pressure of 100 psig (6.9 bars) is indicated on the gauge.</p> <p>Air leakage from the suspension air system or the air brake system. Listen for air leakage due to loose fittings or damaged air lines, air springs, brake actuators or control valve. Tighten loose fittings to stop leakage and/or replace worn or damaged parts.</p>
Air springs deflate rapidly when vehicle is parked.	<p>Air leakage from the suspension air system. Listen for air leakage due to loose fittings between air tank and air suspension or damaged air lines, air springs or height control valve. Apply a soapy solution to connections and air springs if necessary to check for bubbles (leaks). Tighten loose fittings to stop leakage and/or replace worn or damaged parts with new ones.</p>
Chassis ride height too high or too low.	<p>Height control valve out of adjustment. Readjust the height control valve.</p>
Air springs ruptured.	<p>Air spring cut or punctured. Replace.</p>
Air spring failed.	<p>Continual or repeated over-extension of the air spring. Visually inspect for broken or loose shock absorber or shock absorber mounting bracket. Reconnect loose parts and replace any defective parts. Check the adjustment of the height control valves.</p> <p>Air spring(s) worn out. Replace.</p>
Air spring(s) fail to fully deflate when all weight is removed from the suspension.	<p>Restricted air lines(s) between the height control valve and the air spring(s). Disconnect the height control valve linkage and rotate the actuating lever to the 45° down position. If the air spring(s) remain inflated, check for pinched or blocked line(s).</p>
Shock absorber failures.	<p>Over-extension. Mislocated shock brackets. Improper shocks installed. Check for oil leaking from shock. If worn out from length of service, replace.</p>
Excessive tire wear.	<p>Axles mis-aligned. Realign axles per vehicle manufacturer's recommendations. See Axle Alignment procedure on page 8.</p>
Vehicle unstable or handles poorly.	<p>Loose frame bolts or attachments. Tighten frame bolts and attaching parts to proper specifications.</p> <p>Cracked or loose frame crossmembers. Repair or replace damaged frame members, and torque all nuts and bolts to proper torque specifications.</p> <p>Check the ride height. Readjust if necessary.</p> <p>Loose transverse beam connection. Replace worn bushings, retorque to specifications.</p> <p>Loose or worn pivot connection. Retorque to specification and/or rebush if necessary.</p> <p>Cracked or loose equalizing beam plates or transverse beam. Replace failed part.</p> <p><i>Contact your vehicle manufacturer for his recommendation if these possible causes and effects do not solve the vehicle handling problem.</i></p>
Constant noise from suspension.	<p>Loose shock, track bar, or torque rod. Retighten to torque specified in Torque Specifications on page 5.</p> <p>Loose equalizing beam plate connection at frame bracket, axle adapter and/or transverse beam. Retighten appropriate hardware to torque specified in Torque Specifications on page 5.</p> <p>Rocks wedged between axle adapter and transverse beam. Remove debris shield and remove rocks, then reinstall debris shield.</p>
Drive-Line vibration.	<p>Pinion angle out of adjustment. Readjust using instructions on page 9.</p> <p>Incorrect ride height. Readjust using instructions on page 8.</p>

Holland USA, Inc. Facilities:

Dumas, AR Muskegon, MI
Holland, MI Warrenton, MO
Monroe, NC Wylie, TX

Ph: 888-396-6501 Fax: 800-356-3929

Holland International, Inc.

Holland, MI
Phone: 616-396-6501
Fax: 616-396-1511

Holland Hitch of Canada, Ltd.

Woodstock, Ontario • Canada
Phone: 519-537-3494
Fax: 800-565-7753

Holland Equipment, Ltd.

Norwich, Ontario • Canada
Phone: 519-863-3414
Fax: 519-863-2398

Holland Hitch Western, Ltd.

Surrey, British Columbia • Canada
Phone: 604-574-7491
Fax: 604-574-0244