

SAF BALL RACE TURNTABLES
HEAVY-DUTY DOUBLE RACE STYLE



HEAVY-DUTY DOUBLE RACE TURNTABLES
FOR COMMERCIAL TRAILERS AND
FIFTH WHEEL MOUNTING

SAF BALL RACE TURNTABLES



SAF Double Ball Race Turntables have been developed exclusively for installation in commercial transport vehicles. Their purpose is to transmit both the vertical load and drawbar pull.

SAF Turntables are built to the highest standards and are designed to meet high performance requirements.

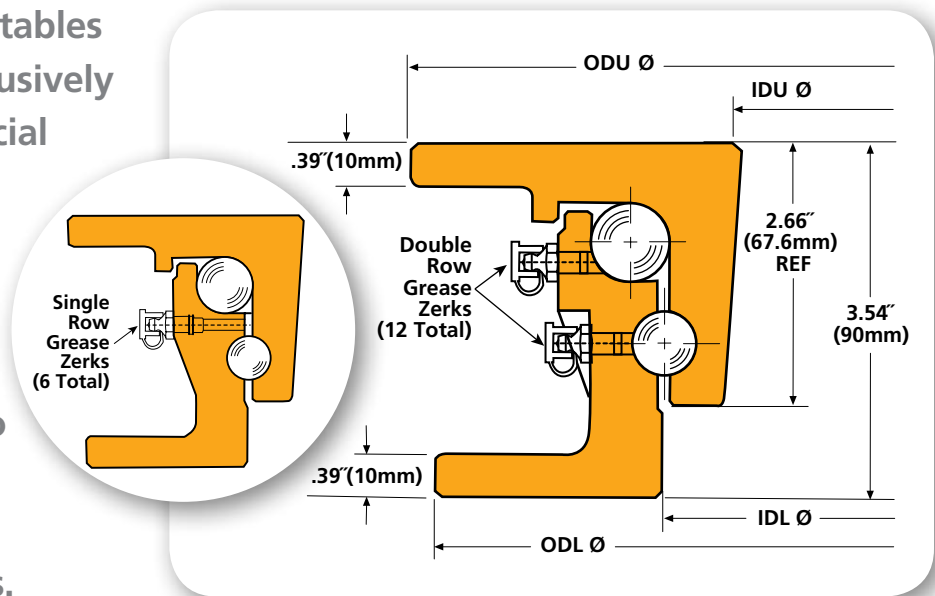

MODEL NUMBER	WEIGHT	GREASE ZERKS	OUTER DIAMETER UPPER	INNER DIAMETER UPPER	OUTER DIAMETER LOWER	INNER DIAMETER LOWER
			ODU	IDU	ODL	IDL
1038300000240	183 lbs	2 Row	39.37"	32.76"	38.86"	34.33"
1038300000810	83 kg	1 Row	1000 mm	832 mm	987 mm	872 mm
1038300000250	209 lbs	2 Row	43.39"	36.69"	43.11"	38.27"
1038300000820	95 kg	1 Row	1102 mm	932 mm	1095 mm	972 mm
1038300000790	207 lbs 94 kg	2 Row	43.54" 1106 mm	36.93" 938 mm	43.11" 1095 mm	38.86" 978 mm
1038300000800	207 lbs 94 kg	2 Row	43.54" 1106 mm	36.93" 938 mm	43.11" 1095 mm	38.86" 978 mm

MODEL NUMBER	DESCRIPTION	VERTICAL CAPACITY
1038300000240	39" (1000 mm) OD	36,000 lbs (160 kN)
1038300000810		
1038300000250	43" (1100 mm) OD	45,000 lbs (200 kN)
1038300000820		
1038300000790	44" (1106 mm) OD	45,000 lbs (200 kN)
1038300000800	44" (1106 mm) OD	45,000 lbs (200 kN)

Double Ball Race – Ball Size: .79" (20 mm) and .63 (16 mm)

MOUNTING HOLES

SAF Turntables are available as either undrilled or with a standard drill pattern. Custom drill patterns are processed on customer request and order placement. If the ball race turntable mounting holes are customer drilled, the name plate (filler plug) must be offset to the direction of travel by approximately 45 degrees at the lower ring. Mounting holes are not allowed in the area around either name plate.

MODEL	LOWER RING BOLT PATTERN CIRCLE		UPPER RING BOLT PATTERN CIRCLE	
	INCH	MM	INCH	MM
1038300000240	37.50	952	38.00	966
1038300000810	37.50	952	38.00	966
1038300000250	41.75	1061	42.32	1075
1038300000820	41.75	1061	42.32	1075

Mounting Hole Size: .67" (17 mm)

1038300000240

&

1038300000810

Single Row Grease Zerk
(6 Total)

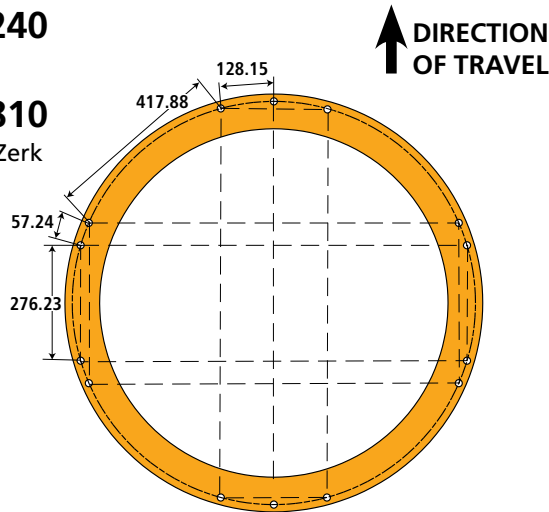

UPPER RING

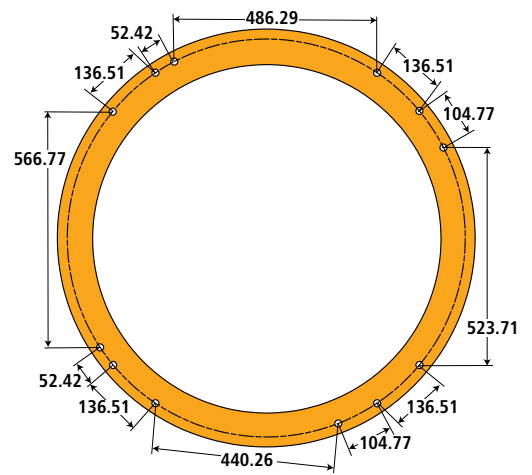

LOWER RING
(Looking from below)

1038300000250

&

1038300000820

Single Row Grease Zerk
(6 Total)

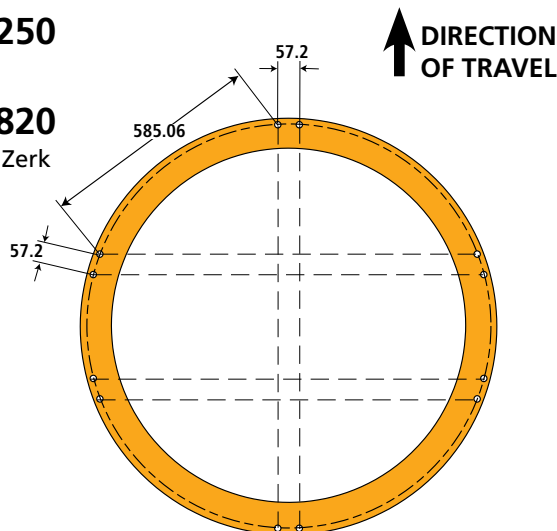

UPPER RING

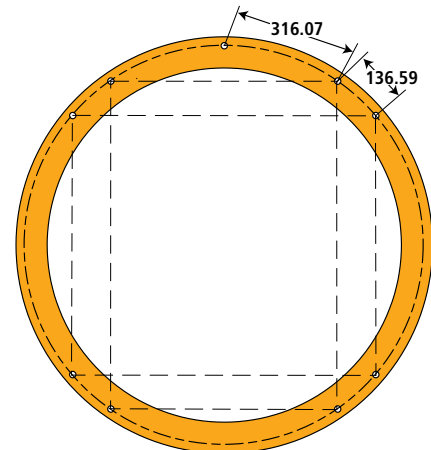

LOWER RING

MODEL	LOWER RING BOLT PATTERN CIRCLE		UPPER RING BOLT PATTERN CIRCLE	
	INCH	MM	INCH	MM
1038300000790	41.75	1061	42.10	1070
1038300000800	41.90	1064	42.40	1076

Mounting Hole Size: .75" (19 mm)

1038300000790

↑ DIRECTION OF TRAVEL

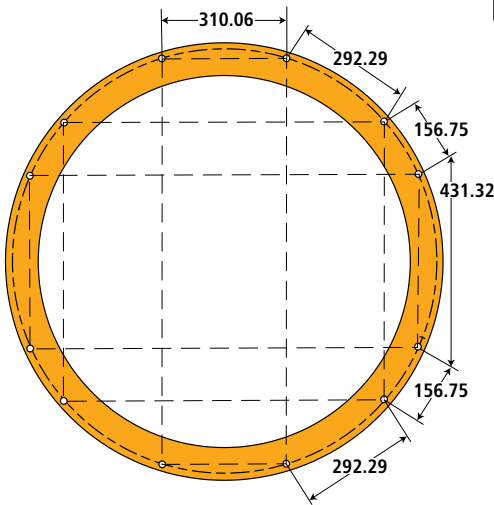

UPPER RING

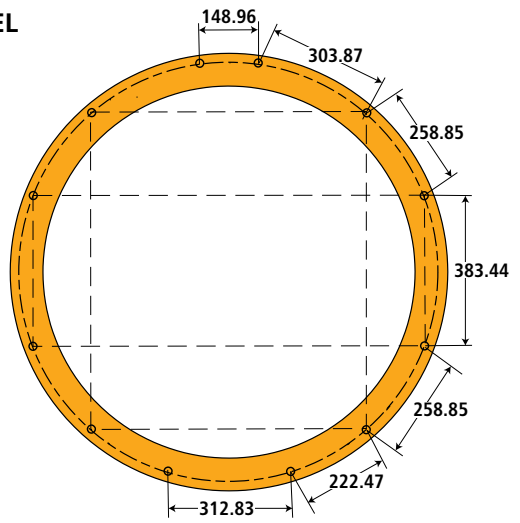

LOWER RING

1038300000800

↑ DIRECTION OF TRAVEL

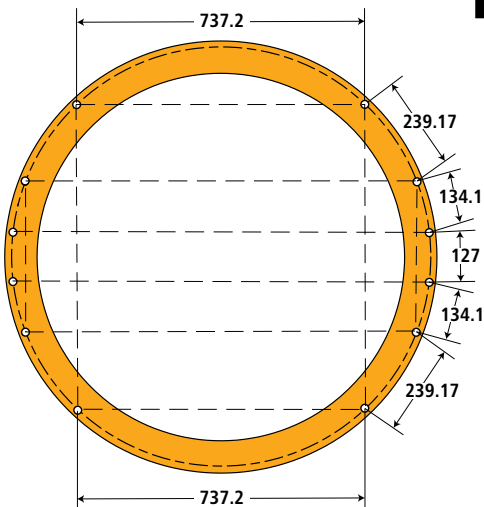

UPPER RING

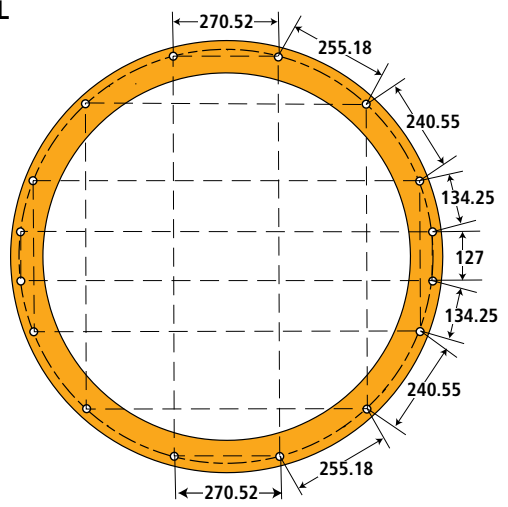

LOWER RING

PRE-INSTALLATION INFORMATION

SAF Turntables must be mounted on the flattest and most distortion proof structure possible. It is required that the turntable be adequately supported by the mounting structure over at least 50% of the mounting surface of the upper and lower flanges. The supported areas must be equally distributed between the direction of travel, and at right angles to this. (Note: Do not weld the turntable to the mounting structure.) Total allowable out of flatness is .05" (1.3 mm). To prevent distortion from occurring, turntables must never be welded to their mounting structure.

The load details and the bolt connection are only valid for operation on roads consisting of less than 10% off-road* conditions.

* Off-road refers to terrain on which a tractor-trailer will operate which is unpaved and rough, or ungraded. Any terrain not considered part of the public highway system falls under this heading.

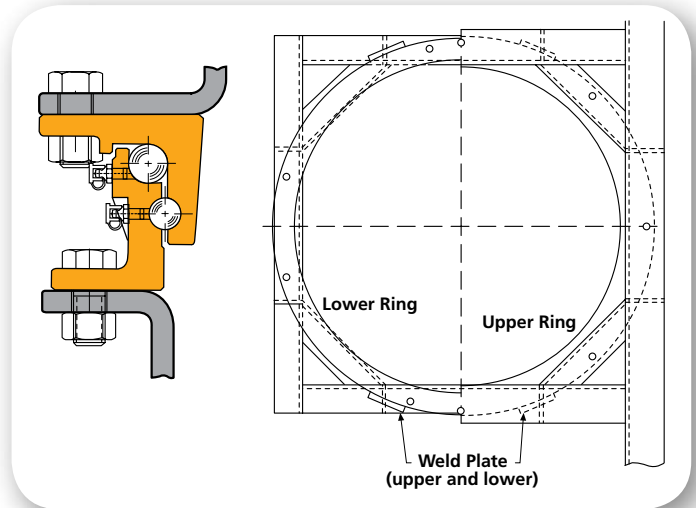

WARRANTY

SAF Turntables are covered by a 1-Year Warranty. Contact your SAF-HOLLAND representative for details.

CENTROLUBE OPTION

The advantage of this central lubricating system is that all lubrication points around the ball race can be lubricated from one lubrication point. The lubricant distributor developed by SAF-HOLLAND guarantees even distribution of the lubricant and consistently good performance.

These central lubricating units can be fitted retrospectively to the ball races you already have in just a few steps. In order to do so, please follow the SAF-HOLLAND installation instructions.

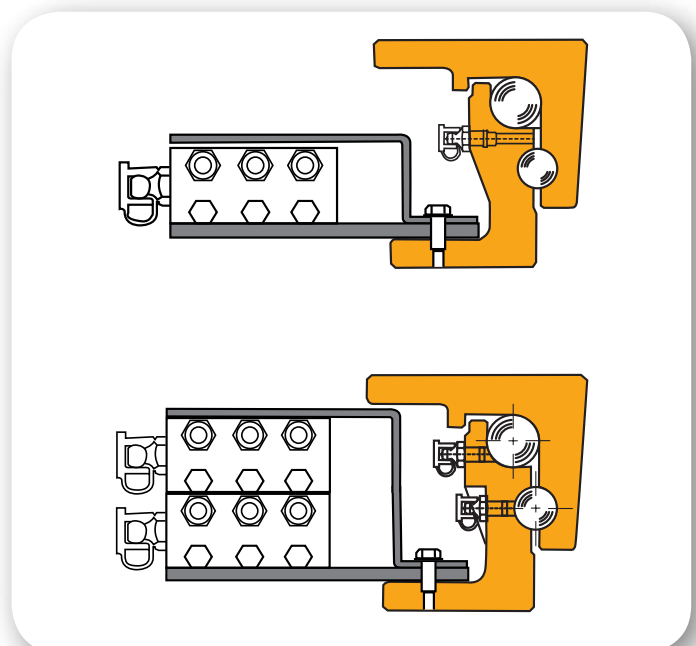

CENTROLUBE	
Complete Central Lubricating System For Ball Races	
BALL RACE PART NUMBER	ORDER NUMBER
1038300000240	2110300000410
1038300000250	
1038300000790	
1038300000800	2110300000370
1038300000810	
1038300000820	



SAF-HOLLAND is a leading supplier of highly efficient components, systems and service programs in the global commercial vehicle industry. Our three core product brands are recognized for delivering innovative solutions that optimize fleet operations in every corner of the world.



**TRAILER AXLES AND
SUSPENSION SYSTEMS**



**COUPLING AND LIFTING
TECHNOLOGIES**



**SUSPENSIONS FOR
TRUCKS AND BUSES**

With our team of over 3,000 employees and a worldwide network of over 9,000 service partners, we serve our fleet customers with know-how and passion, and always focused on one target: **Engineering your road to success.** Anywhere in the world. Under any conditions. 365 days a year.

HIGHLY EFFICIENT COMPONENTS AND SYSTEMS FOR TRUCKS AND TRAILERS



ORIGINAL SERVICE PARTS DESIGNED TO KEEP YOU ROLLING

safholland.com

SAF-HOLLAND, Inc.
888.396.6501 Fax 800.356.3929

SAF-HOLLAND Canada Limited
519.537.3494 Fax 800.565.7753

Western Canada 604.574.7491 Fax 604.574.0244