

XA-201 SERIES & XA-201-A-80-L AIR RELEASE WEDGE STOP BLOCK & PLUNGER LOCK REPLACEMENT KIT

RK-09590-W Replacement Kit

Wedge Stop Block & Plunger Lock Replacement Procedures for Holland FW8 (FleetMaster) Fifth Wheels

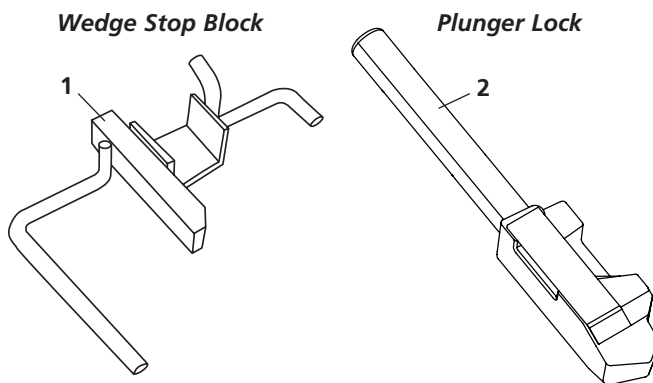

RK-09590-W Replacement Kit

ITEM	DESCRIPTION	PART NO.	QTY.
1	Wedge Stop Block	XA-09590	1
2	Lock, Plunger	XA-10474	1

WARNING DO NOT substitute other or used parts. Improper part combinations can cause the product to couple improperly which, if not avoided, could result in death or serious injury.

IMPORTANT SAFETY INFORMATION

1. All fifth wheel maintenance must be performed by a qualified service technician using proper tools and safe procedures.
2. Use only SAF-HOLLAND original parts.
3. Wear safety goggles during disassembly and assembly of the fifth wheel.
4. Keep fingers away from all potential pinch points in the fifth wheel.
5. Do not weld on this product. Do not deviate from the instructions contained in this manual. Any changes or deviations from these procedures will void all warranties, express or implied, unless prior written consent is obtained from SAF-HOLLAND.
6. Always verify proper operation and adjust the fifth wheel according to the procedures outlined in the FW8 (FleetMaster) Owners Manual.

IMPORTANT: DO NOT attempt repairing or rebuilding if the top plate is cracked or distorted or if the lock pins do not fit tightly in the top plate as the top plate may fail or the locks may malfunction.

WARNING Failure to use tight fitting lock pins in a properly functioning top plate may cause the locks to malfunction, causing a loss of vehicle control which, if not avoided, could result in death or serious injury.

WARNING Failure to replace a malfunctioning top plate may cause loss of vehicle control which, if not avoided, could result in death or serious injury.

WEDGE STOP BLOCK & PLUNGER INSTALLATION

Determine If Wedge Stop Block And Plunger Lock With Strap Is Required

1. Check your top plate. If it is equipped with a cast in wedge stop, as shown in **FIGURE 1**, installation of the wedge stop block (**XA-09590**) and plunger lock (**XA-10474**) is not necessary.

FIGURE 1

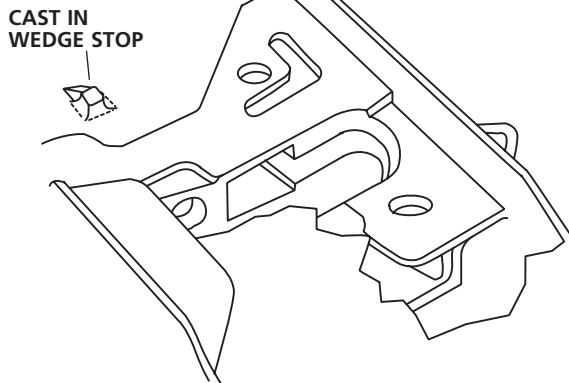

Wedge Stop Block Installation

1. If you do not have a cast in wedge stop, install a wedge stop block (**XA-09590**) into the top plate as shown in **FIGURE 2**.

FIGURE 2

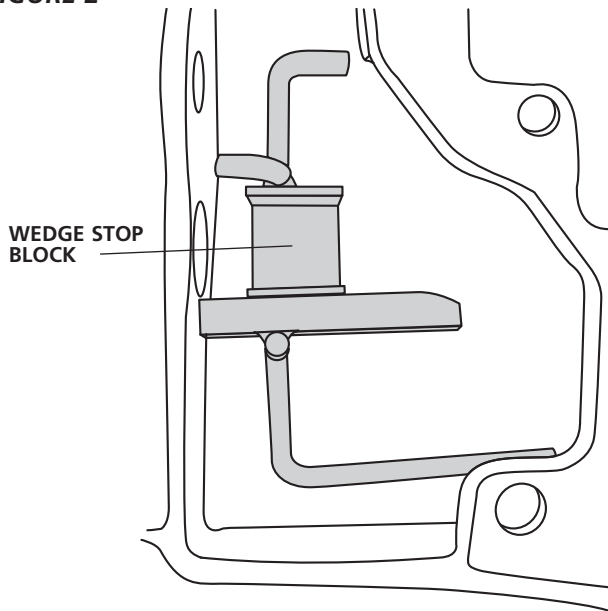

Plunger Installation

1. When using a wedge stop block, the plunger spring and plunger are positioned in the "C" channel position, as shown in **FIGURE 3**.

FIGURE 3

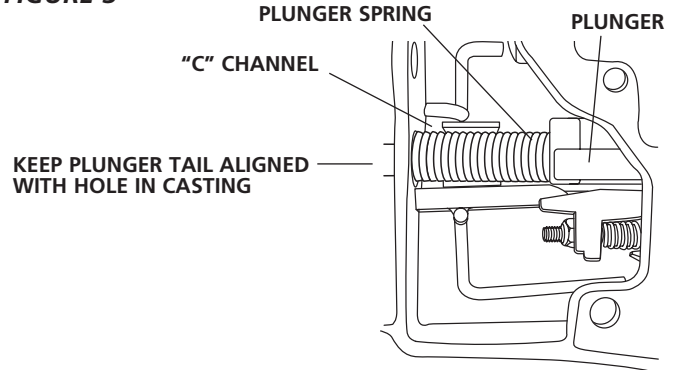

2. Install plunger per Steps 2 – 4 on Page 5 of XL-FW355-03.
3. Attach the 4.5" long release arm spring loop to the wedge stop block loop as shown in **FIGURE 4**.

FIGURE 4

