

HOLLAND IN-CAB AIR RELEASE

ICR FEATURE ENHANCES SAFETY, IMPROVES DRIVER EFFICIENCY
AND REDUCES OPERATION COSTS - NOW AVAILABLE WITH FIVE
DIFFERENT TOP PLATE MODELS

IN-CAB AIR RELEASE

FIFTH WHEEL SYSTEMS

PRODUCTIVE DRIVERS EQUAL A PRODUCTIVE OPERATION

Many factors affect driver productivity. Uncoupling the fifth wheel is one. In the past, uncoupling was done manually. That had some disadvantages that affected driver comfort, safety, productivity, and your profits. In response, the HOLLAND In-Cab Air Release system has been developed to permit drivers to quickly and safely control the uncoupling process from the cab.

SAFE

The In-Cab Air Release system is designed to assure that the fifth wheel lock release can only be operated when the vehicle is standing still with brakes applied. The unique air-assisted interlock design absolutely prevents accidental release of the fifth wheel lock, while still allowing manual release operation if necessary.

EFFORTLESS

The optional In-Cab Air Release system allows the in-cab release of the fifth wheel locking mechanism. With just a simple pull of a dash-mounted air switch, a pneumatic cylinder on the fifth wheel will effortlessly open the locking mechanism. Gone are the days of reaching in to grasp a greasy release handle.

EFFICIENT

Reduce the time your driver spends manually locking and unlocking the fifth wheel. Less manual interaction with the fifth wheel limits potential injuries that can lead to expensive worker's compensation claims.

CONSISTENT

Backed by SAF-HOLLAND Performance Guarantee, the In-Cab Air Release system will work reliably when you need it to — Every Time.

SIMPLE, EASY TO OPERATE, IN-CAB SYSTEM

Here's how it works.

- Set the tractor parking brake to activate the system.
- Then operate the dash-mounted button to activate a pneumatic cylinder on the fifth wheel to open the lock.



The system allows manual release operation, if necessary.

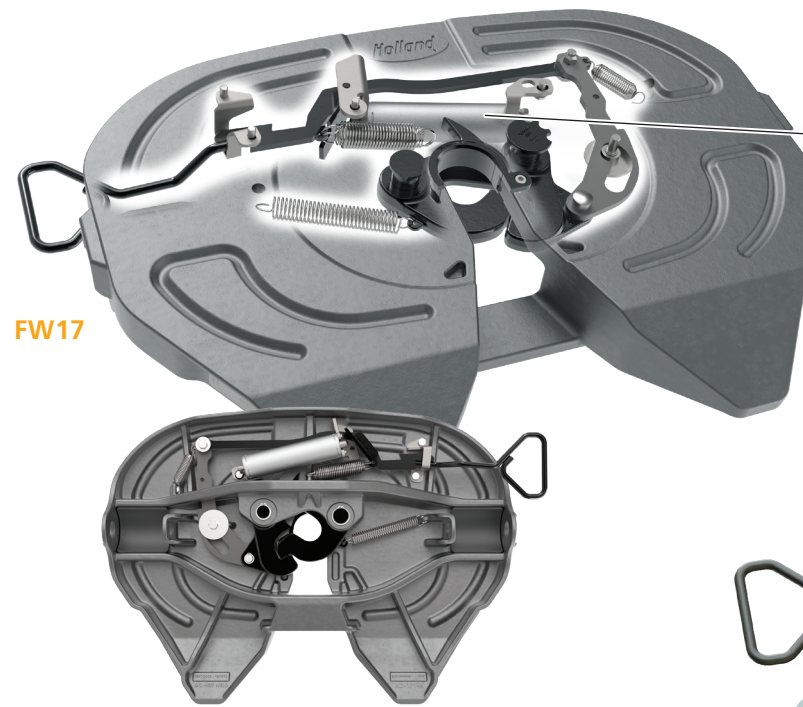

FW17

EASY TO ORDER

To add the HOLLAND Air Release system to your HOLLAND fifth wheel model specification, simply add *Option Code 80* to your spec. It is available from all major OEMs.

Ask your SAF-HOLLAND sales representative about the NoLube™ feature for an even higher level of enhanced fleet operation efficiency.

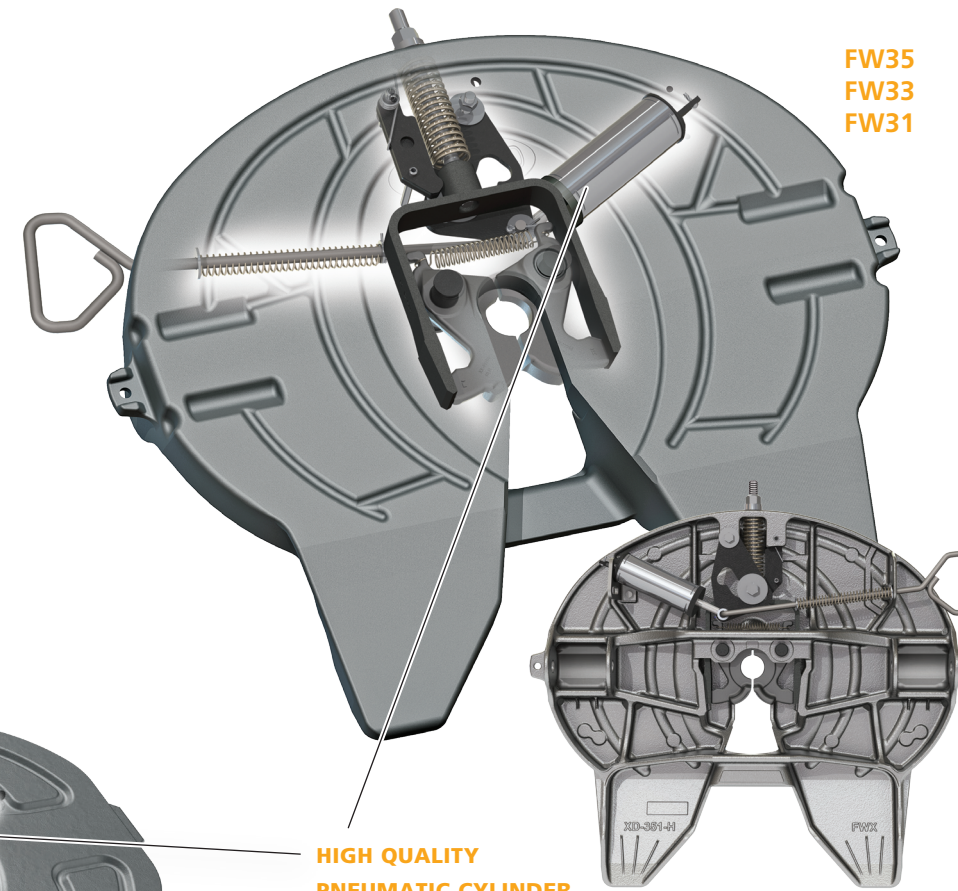

FW35
FW33
FW31

HIGH QUALITY PNEUMATIC CYLINDER

is corrosion resistant ensuring long life and consistent operation.

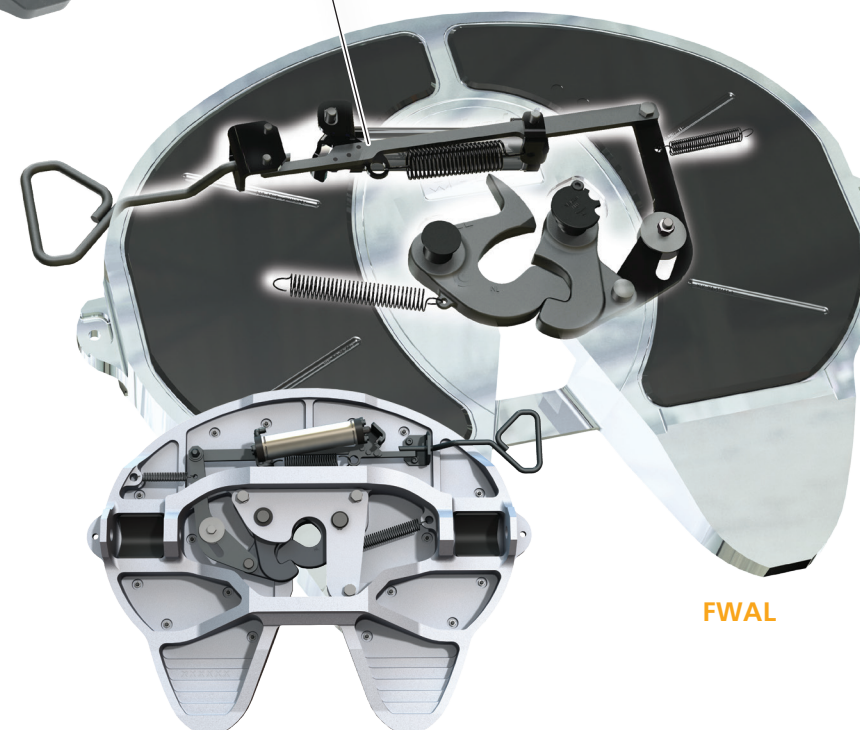

FWAL



THE FLEET ADVANTAGES



- **DRIVER EFFICIENCY IS IMPROVED**
The HOLLAND Air Release system helps them stay on schedule, especially with today's diverse drivers.
- **DRIVERS ARE MORE COMFORTABLE**
Safer, less strain, fatigue, and potential for injury, especially in bad weather or when access to the release handle is difficult. You may even reduce workers compensation costs.
- **DRIVERS WILL FEEL BETTER**
No more greasy, grimy hands and clothes, or unnecessary cleanup time.

PULL A SWITCH AND PULL AWAY



WHAT DOES THE
PERFORMANCE
GUARANTEE
MEAN TO YOU?

For the stated Performance Guarantee period: The HOLLAND fifth wheel is guaranteed to provide maximum operation performance. In the unlikely case of wear requiring lock mechanism replacement, SAF-HOLLAND will cover the cost of parts, labor and freight.* In addition, they are covered with a 2-Year warranty on the pneumatic cylinder.

* Refer to specific model warranty for full details.



TRAILER AXLES AND
SUSPENSION SYSTEMS



COUPLING AND
LIFTING SYSTEMS



SUSPENSIONS FOR
TRUCKS AND BUSES



SUSPENSIONS AND
AXLE SYSTEMS



V.ORLANDI
TOWING
SYSTEMS



TRAILER AXLES/SUSPENSIONS,
COUPLING AND LIFTING
SYSTEMS

safholland.com

SAF-HOLLAND, Inc.
888.396.6501

SAF-HOLLAND Canada Limited
519.537.3494
Western Canada 604.574.7491

SAF-HOLLAND Mexico
52.55.5456.8641