

IMPORTANT!

PROCEDURES FOR INSTALLATION OF SECONDARY LOCK ON MODELS **ORIGINALLY** EQUIPPED WITH SWINGING LOCK AND SECONDARY LOCK AS SHOWN IN **FIGURE A**, BELOW.

THESE INSTRUCTIONS REPLACE THE “**SECONDARY LOCK INSTALLATION**” SECTION IN THE ATTACHED MANUAL.

1. Coat the lock pin hole in the secondary lock (10) with Never-Seez[®] (supplied with kit). **DO NOT** use any substitute lubricant.
2. Install the secondary lock release handle (9) into the casting. Install the secondary lock (10) on to the handle. Install cotter pin (8) in handle and spread cotter pin. Drive the secondary lock pin (3) through the holes in the casting and secondary lock and secure with cotter pin (2). Install grease fitting (25) in the lock pin so that the fitting faces the side and will be accessible from the left side of the tractor.

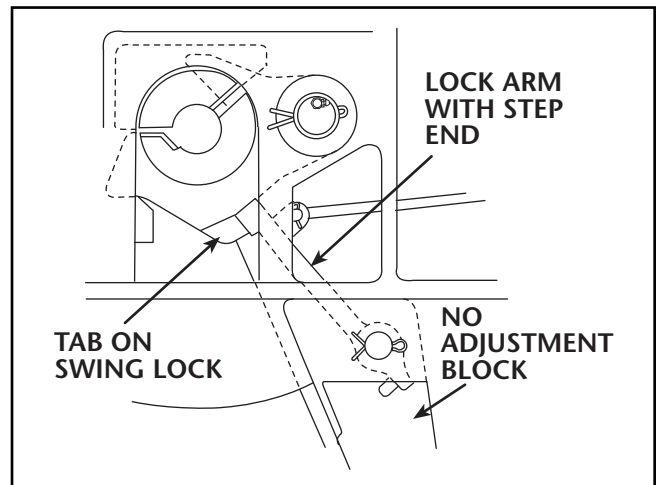

FIGURE A

3. Move the secondary lock handle to the closed position. Check the location of the end of the secondary lock in relation to the swinging lock. It should be $3/16'' (0.188'') \pm 1/16'' (0.06)$ from point (A) on the swinging lock (see **Figure B**) when the secondary lock is resting against the casting at point (B).
4. If the secondary lock is not in the current position, install a secondary lock adjustment block (36) as shown in **Figure B**. Move the adjustment block until proper adjustment is achieved, then weld the adjustment block in position, as shown in **Figure B**. After welding, check the dimension and for proper operation of the secondary lock.

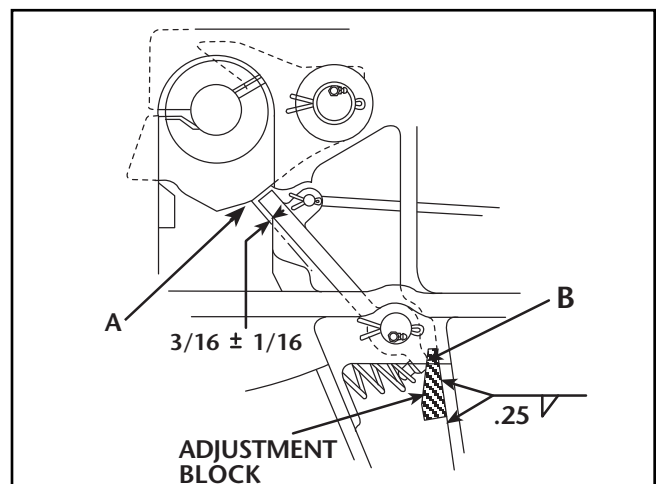

FIGURE B

IMPORTANT!

PROCEDURES FOR INSTALLATION OF SECONDARY LOCK ON MODELS **ALREADY** EQUIPPED WITH ADJUSTMENT BLOCK AS SHOWN IN **FIGURE C**, BELOW.

THESE INSTRUCTIONS REPLACE THE “**SECONDARY LOCK INSTALLATION**” SECTION IN THE ATTACHED MANUAL.

1. Pre-install the secondary lock (10) in the closed position in the casting. Do not install spring, handle, or secondary lock pin yet. Align the lock pin holes and rotate the secondary lock up against the adjustment block. Check the location of the end of the secondary lock in relation to the swinging lock. It should be $3/16''$ (0.188'') $\pm 1/16''$ (0.06'') from point (A) on the swinging lock (see Figure D) when the secondary lock is resting against the adjusting block at point (B).

A. If the dimension is less than $1/8''$ (0.125''):

Mark the area where the secondary lock made contact with the adjusting block. Remove the secondary lock, then place a bead of weld on the adjusting block where the secondary lock makes contact with the adjusting block and grind smooth. Do not weld on the secondary lock. After welding, recheck as in *Step 1*, above.

B. If the dimension is more than $1/4''$ (0.25''):

Mark the area where the secondary lock makes contact with the adjusting block. Remove the secondary lock, then grind on the adjusting block. **CAUTION:** A small amount of grinding on the adjusting block results in a large movement of the secondary lock. After grinding, recheck, as in *Step 1*.

- C. After a final check of the dimension, coat the lock pin hole in the secondary lock (10) with Never-Seez® (supplied with kit). **DO NOT** use any substitute lubricant.

- D. Install the secondary lock release handle (9) into the casting. Install the secondary lock (10) onto the handle. Install cotter pin (8) in handle and spread cotter pin. Drive the secondary lock pin (3) through the holes in the casting and the secondary lock and secure with cotter pin (2). Install grease fitting (25) in lock pin so that the fitting faces the side and will be accessible from the left side of the tractor.

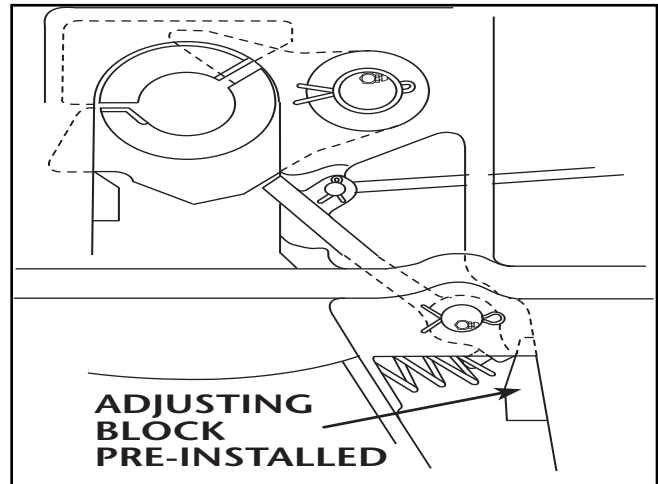

FIGURE C

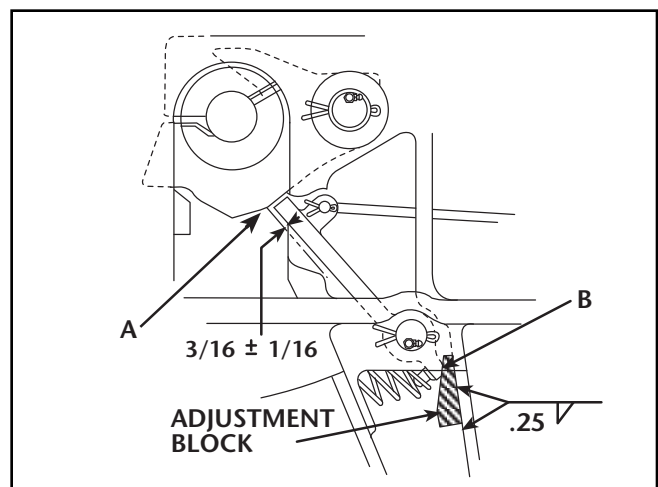

FIGURE D