



FIFTH WHEEL

LUBE PLATE AND POCKET INSERT REPLACEMENT



FleetMaster LowLube
 XA-231 Series Top Plates
 Used on FW83 Series Fifth Wheels

This manual contains procedures to replace the lube plates and pocket inserts on the XA-231 Series LowLube Fifth Wheel Top Plate. To rebuild the fifth wheel top plate locking mechanism, refer to Holland publication XL-FW355-XX Rebuild Procedures for XA-201 and XA-231 Series Fifth Wheel Top Plates. To replace the lube tube, refer to Holland publication XL-FW426-XX.

RK-231-1
LUBE PLATE REPLACEMENT KIT

Item	Part No.	# Req'd.	Part Name
1	XA-10194	2	Lube Plate
2	XB-08931	14	Locknut

RK-PKT-2
POCKET INSERT REPLACEMENT KIT

Item	Part No.	# Req'd.	Part Name
1	XD-08908	2	Pocket Insert
2	XB-09422	1*	Tape Pad

*2 tape strips required; 2 provided as spares.

RK-231-3
LUBE PLATE AND POCKET INSERT REPLACEMENT KIT

Item	Part No.	# Req'd.	Part Name
1	XA-10194	2	Lube Plate
2	XB-08931	14	Locknut
3	XD-08908	2	Pocket Insert
4	XB-09422	1*	Tape Pad

*2 tape strips required; 2 provided as spares.

LUBE PLATES AND POCKET INSERTS ARE SOLD IN PAIRS ONLY

⚠ WARNING

Before attempting any replacement procedure you must read and understand the following:

- DO NOT attempt to replace components on any XA-231 fifth wheel without following the instructions contained in this manual.
- DO NOT modify, change, or add to the product. Use only genuine Holland parts.
- Perform all procedures in a lighted area, clear of obstacles and other personnel.

- Always wear safety goggles during removal, installation, or service procedures. DO NOT strike any part of the product with a steel hammer.
- Observe standard precautions when lifting.
- Always verify proper operation and adjust the fifth wheel following the procedures contained in this manual before placing back in service.

U.S. Patent #5,522,613. Other patents pending.

BEFORE REPLACING THE LUBE PLATES OR POCKET INSERTS

Review the guidelines below. You may find that component replacement is unnecessary. If component replacement is required, check the front page of these instructions to be sure you have the correct components for your fifth wheel.

LUBE PLATES

Thoroughly steam clean the top surface of the fifth wheel and replace the lube plates if:

- ❑ One or both lube plates is missing; or
- ❑ A straight edge laid on the lube plate contacts any portion of the fifth wheel other than the lube plates themselves; or
- ❑ The lube plates are severely chipped, worn, cracked, gouged, bent; or
- ❑ 20% ($\frac{1}{4}$ 0 sq. in.) or more of the lube plate coating is missing from one or both plates due to normal wear or damage

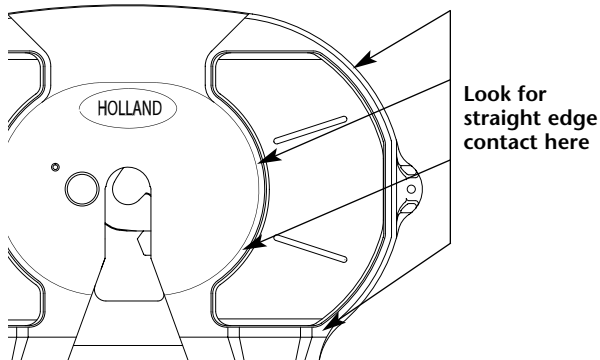

POCKET INSERTS

Replace the pocket inserts if:

- ❑ The pocket insert thickness is $\frac{1}{4}$ / $\frac{1}{6}$ " or less
- ❑ The free vertical movement of the top plate on the bracket is $\frac{1}{2}$ " or greater, without compressing the rubber bushings
- ❑ The pocket inserts are severely chipped, cracked, or gouged

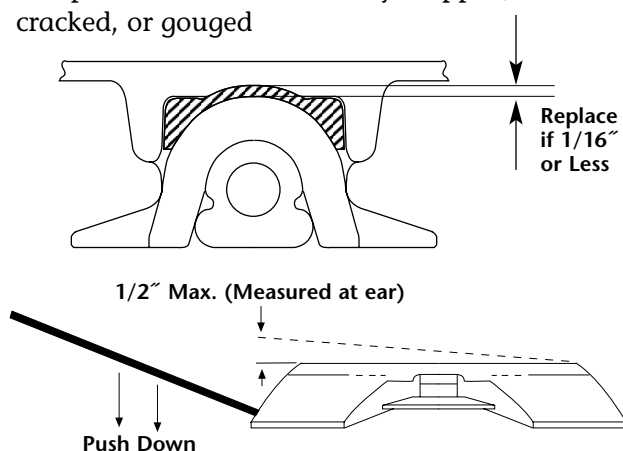

LUBE PLATE REPLACEMENT

CAUTION

When removing the fifth wheel, the pocket inserts maybe loose in the pockets and may fall out causing personal injury when handling. Be sure to pry out and remove loose pocket inserts prior to moving.

1. Remove the fifth wheel from the tractor.

NOTE: It may not be necessary to remove the fifth wheel from the tractor depending on mounting style, cross members, etc. For most situations, removal of the fifth wheel will be necessary.

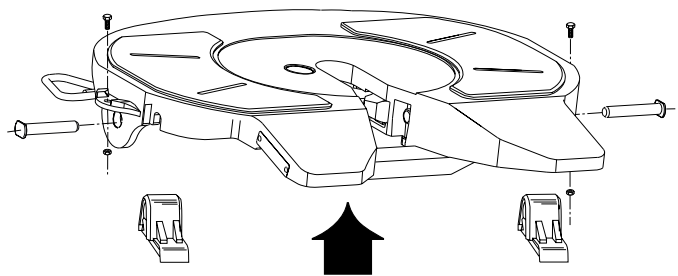

2. Remove and **discard** the ($\frac{1}{4}$) 5/ $\frac{1}{6}$ " lock nuts that secure the lube plates.

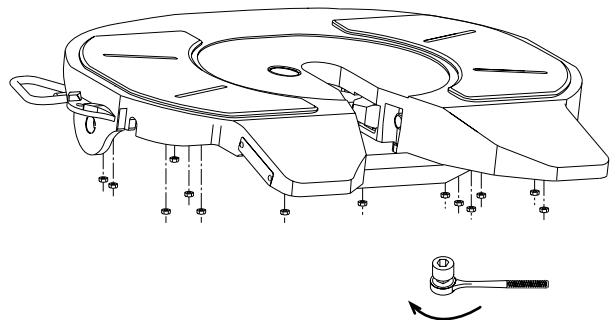

3. Remove the lube plates from the fifth wheel and discard.

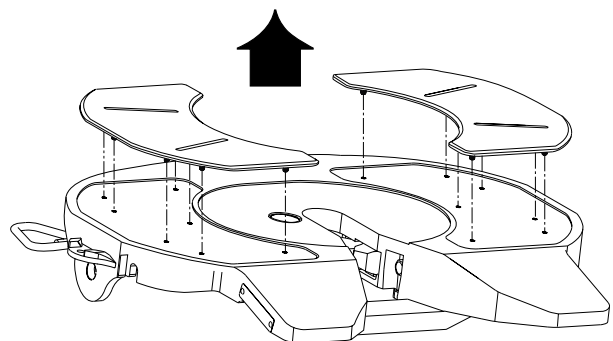

4. Steam clean or use a putty knife to remove dirt, grease, debris, etc. from top plate recess.

NOTE: If steam cleaning, allow to dry or remove excess moisture before next step.

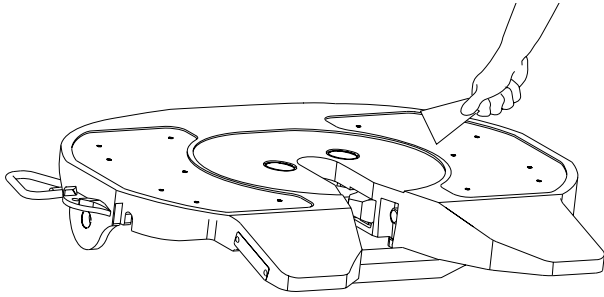

5. Install the new lube plates. Make sure the lube plates are seated flat against the recess in the fifth wheel top plate.

NOTE: Allow bowed lube plates to warm to room temperature before installation.

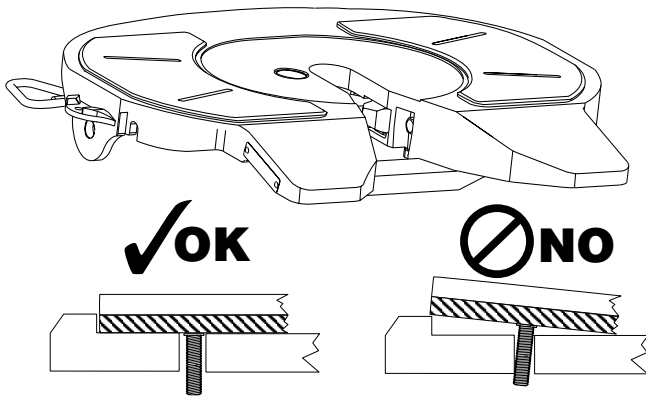

6. Install the new ($\frac{1}{2}$) $\frac{5}{16}$ " lock nuts onto the lube plate studs. Tighten to $\frac{1}{2}$ 2 ft. lbs.

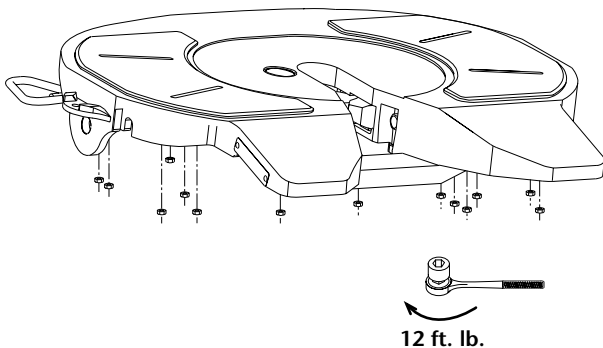

DO NOT LUBRICATE OR OVERTIGHTEN!

Check to see that the lube plates are pulled tight against the recess in the fifth wheel top plate. Reinstall the fifth wheel back onto the tractor.

POCKET INSERT REPLACEMENT

CAUTION

When removing the fifth wheel, the pocket inserts maybe loose in the pockets and may fall out causing personal injury when handling. Be sure to pry out and remove loose pocket inserts prior to moving.

1. Remove the fifth wheel from the tractor.

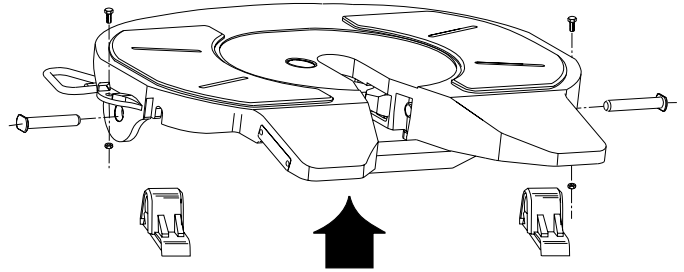

2. Pry out both pocket inserts and discard.

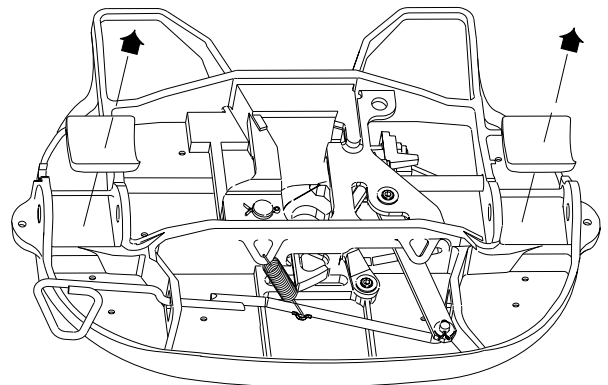

3. Using a putty knife, remove dirt and debris from pockets.

Use suitable grease free cleaner to clean pockets as needed.

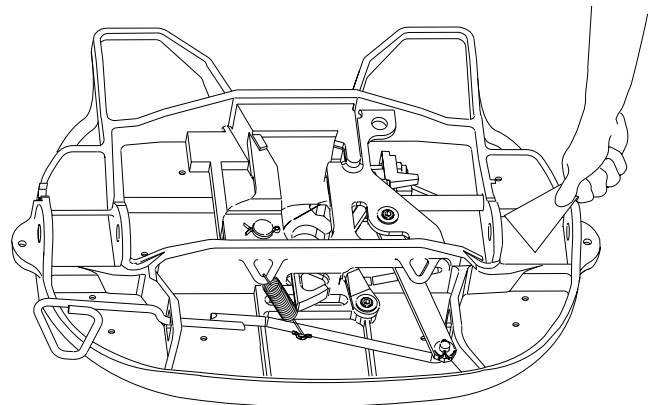

- Attach strip of double face tape in bottom of pockets. Install pocket inserts by pressing down into pockets.

⚠ WARNING

Do not ship fifth wheel top plate with taped in pocket inserts. Pocket inserts could become loose, fall out, and become projectiles causing serious personal injury or death during open trailer or truck transport.

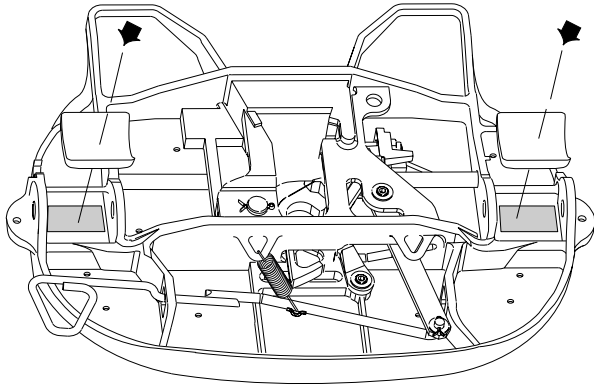

INSTALL TOP PLATE

- Prior to installing top plate, lubricate all lock parts and pivot points as detailed in Holland Publication XL-FW⁴ 8-XX, FW83/XA-23⁴ Owner's Manual.
- Reinstall the fifth wheel onto the tractor. Check for free and proper articulation. Make sure fifth wheel does not bind.

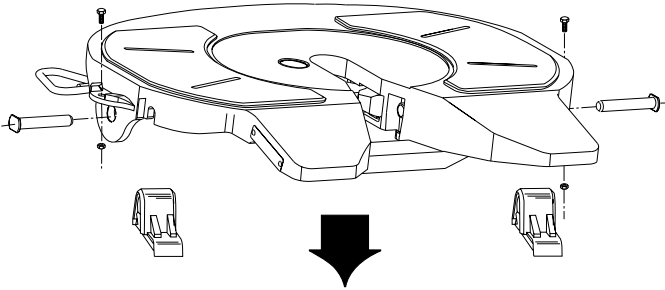

- Check operation of fifth wheel using Holland Kingpin Lock Tester TF-TLN-500⁴.



GO THE DISTANCE.

HOLLAND USA, INC.
 1950 Industrial Blvd. • P.O. Box 425 • Muskegon, MI 49443-0425
 Phone 888-396-6501 • Fax 800-356-3929
 www.thehollandgroupinc.com

Copyright ©May 2002 • The Holland Group, Inc.

Holland USA, Inc. Facilities:

Denmark, SC Muskegon, MI
 Dumas, AR Warrenton, MO
 Holland, MI Whitehouse Station, NJ
 Milpitas, CA Wylie, TX

Ph: 888-396-6501 Fax: 800-356-3929

Holland International, Inc.

Holland, MI
 Phone: 616-396-6501
 Fax: 616-396-1511

Holland Hitch of Canada, Ltd.

Woodstock, Ontario • Canada
 Phone: 519-537-3494
 Fax: 800-565-7753

Holland Equipment, Ltd.

Norwich, Ontario • Canada
 Phone: 519-863-3414
 Fax: 519-863-2398

Holland Hitch Western, Ltd.

Surrey, British Columbia • Canada
 Phone: 604-574-7491
 Fax: 604-574-0244