

Troubleshooting Guide

FW35 (XA-351) Fifth Wheel

Before proceeding, verify that your fifth wheel top plate is a XA-351 model by following the 3 steps below:

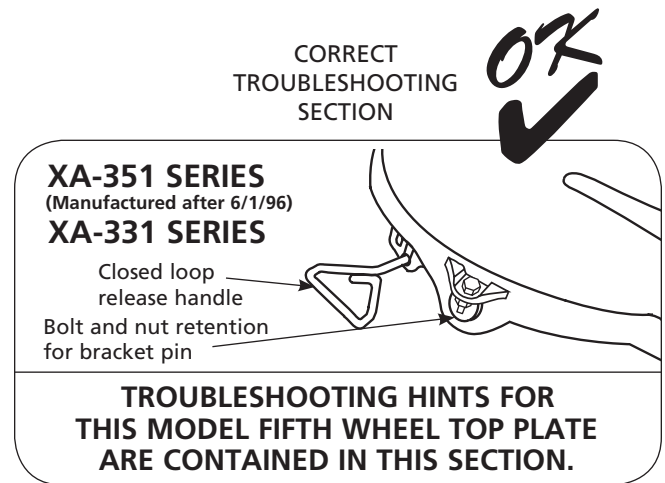
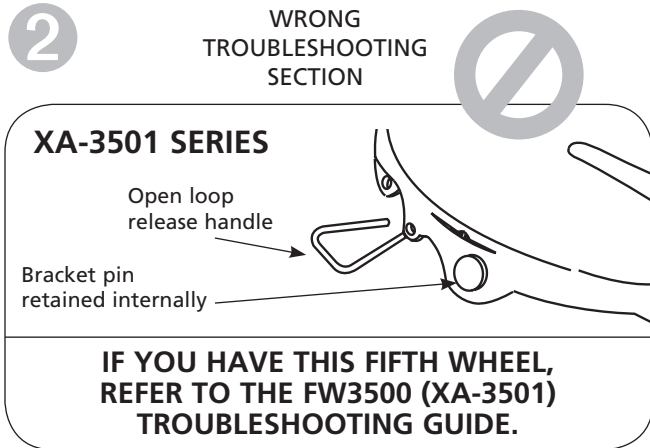
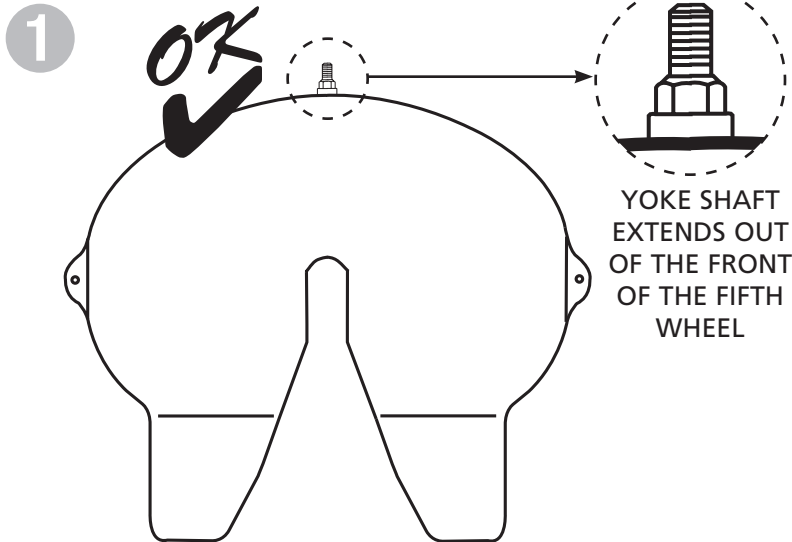

3

Serial Number Tag Identification

For this troubleshooting section, the part number on the serial number tag should begin with one of the following:

- FW35
- XA-351

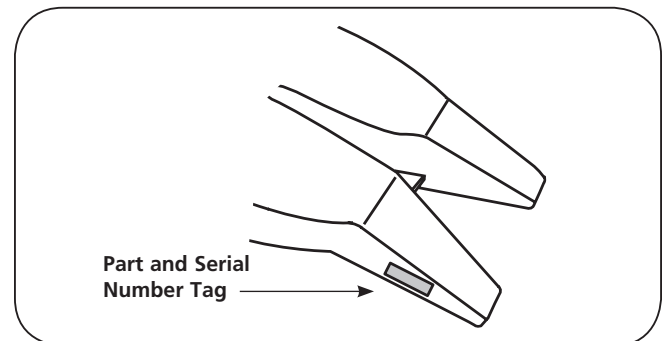
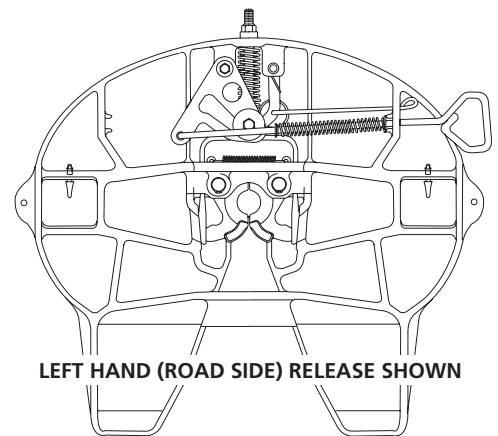



Table of Contents

Difficult to uncouple from trailer	3 – 4
Difficult to couple to trailer	4 – 6
Movement within jaw	6
Lock pins rising	7
Hard steering or binding	7
FW35 (XA-351) exploded view	8



REBUILD KIT NUMBERS

Left Hand Release

- RK-351-A-L (w/Automatic Secondary Lock)
- RK-351-A-02-L (w/Manual Secondary Lock)

Right Hand Release

- RK-351-A (w/Automatic Secondary Lock)
- RK-351-A-02 (w/Manual Secondary Lock)

PROBLEM: Difficult to uncouple from trailer

Cause

1. The secondary lock is not released.
2. The tractor may be putting pressure against locks (pulling locks tight against kingpin).
3. Tractor too low.
4. Rust or grime build-up on locking mechanism.
5. Bent kingpin, damaged upper coupler plate or improper use of "lube plate".
6. Bent kingpin, damaged bolster plate, or improper user of "lube plate".

Remedy

1. If manual secondary, pull manual secondary release handle out and up, hooking it on casting as shown in **Figure 1**.

Figure 1

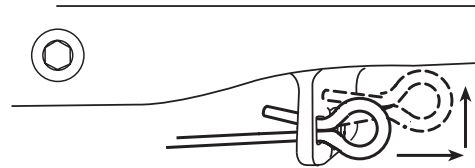

2. Lock the trailer brakes, then back the tractor tight against the kingpin to relieve pressure on the locks. Lock the tractor brakes. Pull release handle.
3. Raise tractor suspension to proper ride height.
4. Spray a light lubricant or apply a lightweight grease on all moving parts including the cam plate, yoke, lock pins, and release handle and spring. Operate several times to work in the lubricant. Follow recommended lubrication schedule as detailed in SAF-HOLLAND Service Bulletin XL-SB036.
5. Check the kingpin and upper plate coupler as detailed in SAF-HOLLAND Service Bulletin XL-SB020. Remove any improperly installed or improperly specified lube plates. Refer to SAF-HOLLAND Service Bulletin XL-SB004 for lube plate warnings.
6. Check the kingpin with a SAF-HOLLAND TF-0100 kingpin gage and bolster plate with a 48" straight edge – repair or replace as required (see **Figure 2** below, and Service Bulletin XL-SB020).

Figure 2

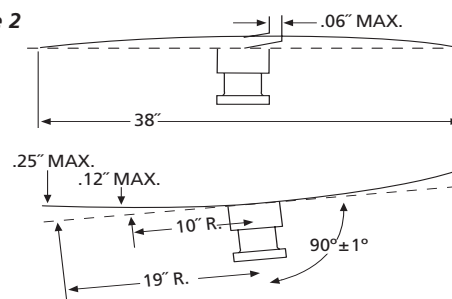
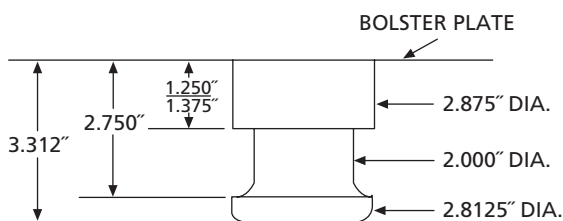

PROBLEM: Difficult to uncouple from trailer *continued*

Cause

7. Fifth wheel locks adjusted too tight.
8. Release handle will not stay out to allow uncoupling.
9. Other missing or damaged release system parts.
10. Casting bent/damaged at throat area restricting movement.

Remedy

7. Re-adjust fifth wheel locks following the procedures in the Lock Adjustment section of the maintenance instructions included with your fifth wheel (SAF-HOLLAND publication XL-FW-308).
8. Fifth wheel must be rebuilt. Obtain the proper rebuild kit for your model top plate.
9. Rebuild fifth wheel with the proper SAF-HOLLAND rebuild kit.
10. Replace entire fifth wheel.

PROBLEM: Difficult to couple to trailer

Cause

1. The trailer may be too high; the kingpin is not entering the locks properly.

Remedy

1. Chock trailer wheels. Then using LOW GEAR, lower the trailer landing gear until the bolster plate is aligned with the fifth wheel, as shown in *Figure 3*.

Figure 3

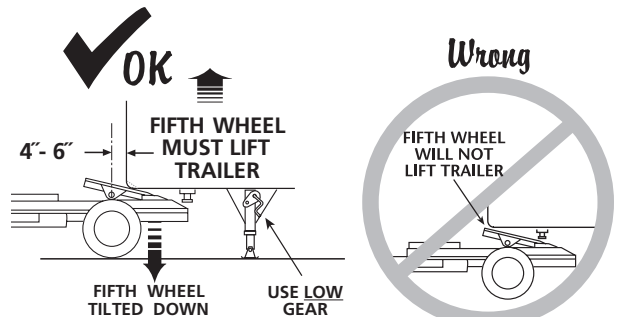

2. Locks are closed.

2. Pull release handle all the way out (see *Figure 4*).

Figure 4

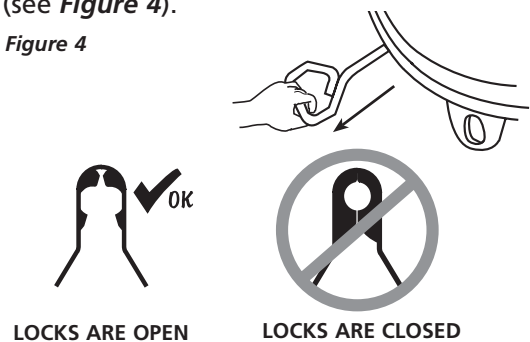

PROBLEM: Difficult to couple to trailer *continued*

Cause

3. Attempting to couple too fast.

Remedy

3. Slowly back the tractor up to the trailer. Pick up the trailer with the fifth wheel. STOP. Then continue backing until the fifth wheel locks firmly to the kingpin. Stopping helps prevent hitting the kingpin too hard.

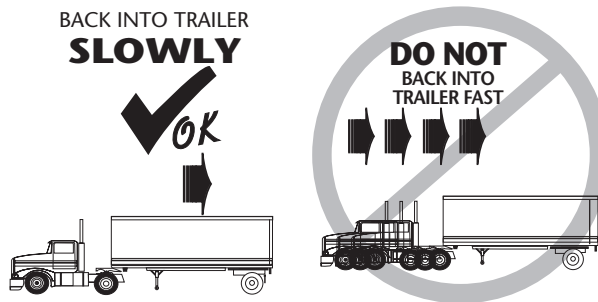

4. Excess accumulation of rust or grime is interfering with lock operation.

4. Thoroughly clean the fifth wheel then relubricate all moving parts including the cam plate, yoke, lock pins, and release handle and spring, as described in SAF-HOLLAND Service Bulletin XL-SB036. Operate several times to work in the lubricant. Follow recommended lubrication schedule as detailed in Service Bulletin XL-SB036.

5. Damaged, bent release handle.

5. Replace release handle using rebuild kit RK-08415-1.

6. Damaged, bent yoke shaft from improper coupling (see **Figure 4**).

6. Inspect for kingpin damage (impact) (see **Figure 5**). If damaged, rebuild fifth wheel with the proper SAF-HOLLAND rebuild kit.

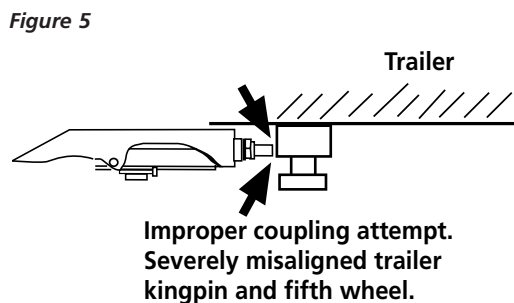

PROBLEM: Difficult to couple to trailer *continued*

Cause

7. Bent kingpin, damaged upper coupler plate or improper use of "lube plate".

Remedy

7. Check the kingpin and upper plate coupler as detailed in SAF-HOLLAND Service Bulletin XL-SB020. Remove any improperly installed or improperly specified lube plates. Refer to Holland Service Bulletin XL-SB004 for lube plate warnings.

Check the kingpin with a Holland TF-0110 kingpin gage and bolster plate with a 48" straight edge – repair or replace as required (see **Figure 6** below, and Service Bulletin XL-SB020).

Figure 6

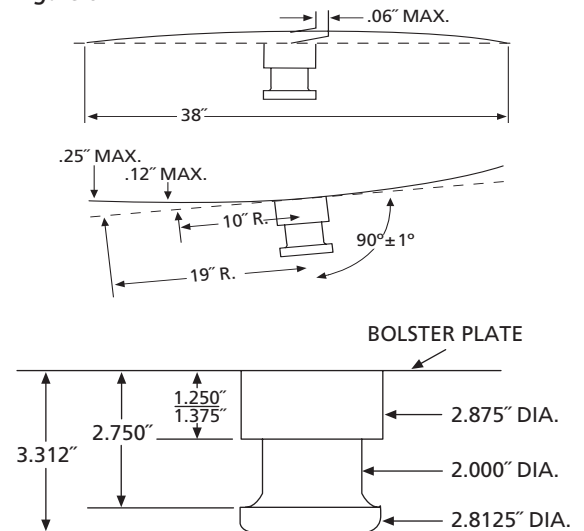

PROBLEM: Excessive movement in the lock jaws

Cause

1. Kingpin wear.
2. Fifth wheel out of adjustment.
3. Fifth wheel cannot be adjusted.

Remedy

1. Check kingpin for acceptable wear with SAF-HOLLAND TF-0110. Replace kingpin, if necessary.
2. Adjust fifth wheel following the procedures in the Lock Adjustment section of the maintenance instructions included with your fifth wheel (SAF-HOLLAND publication XL-FW308).
3. Rebuild fifth wheel using proper rebuild kit.

PROBLEM: Lock pins (XA-07292-T) raising

Cause

1. Kingpin too short, or improperly installed "lube plate".

Remedy

1. Check the kingpin and upper plate coupler as detailed in SAF-HOLLAND Service Bulletin XL-SB020. Remove any improperly installed or improperly specified lube plates. Refer to SAF-HOLLAND Service Bulletin XL-SB-004 for lube plate warnings.

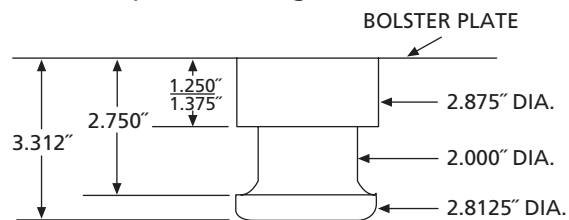

2. Too much vertical movement of jaw(s) in casting.

2. Shim jaw(s) in casting using Part No. XB-05859-1 as shown in **Figure 7**.

NOTE: Do not shim tight. Maintain .040" to .060" free play between the lock jaw and the casting.

Figure 7

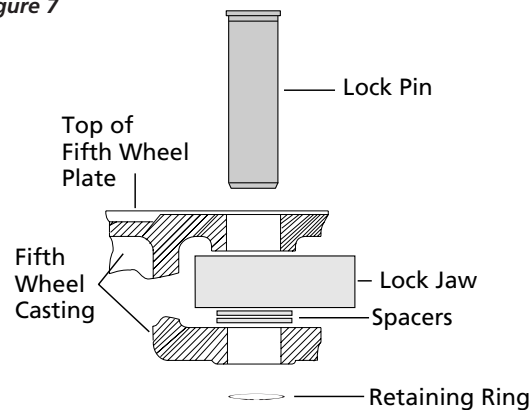

PROBLEM: Hard steering or binding

Cause

1. Lack of lubrication on fifth wheel top surface.
2. Warped trailer upper coupler plate.

Remedy

1. Lubricate top of fifth wheel plate using a high pressure, lithium-based grease. Follow recommended lubrication schedule as described in SAF-HOLLAND Service Bulletin XL-SB036.
2. Check upper coupler plate for flatness. Replace if necessary. (Refer to SAF-HOLLAND Service Bulletin XL-SB020 for additional information on upper coupler plate specifications.)

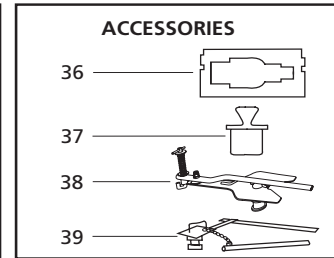
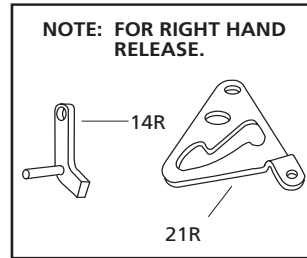
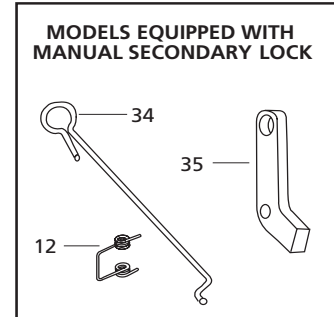
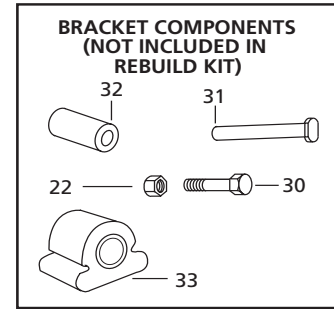
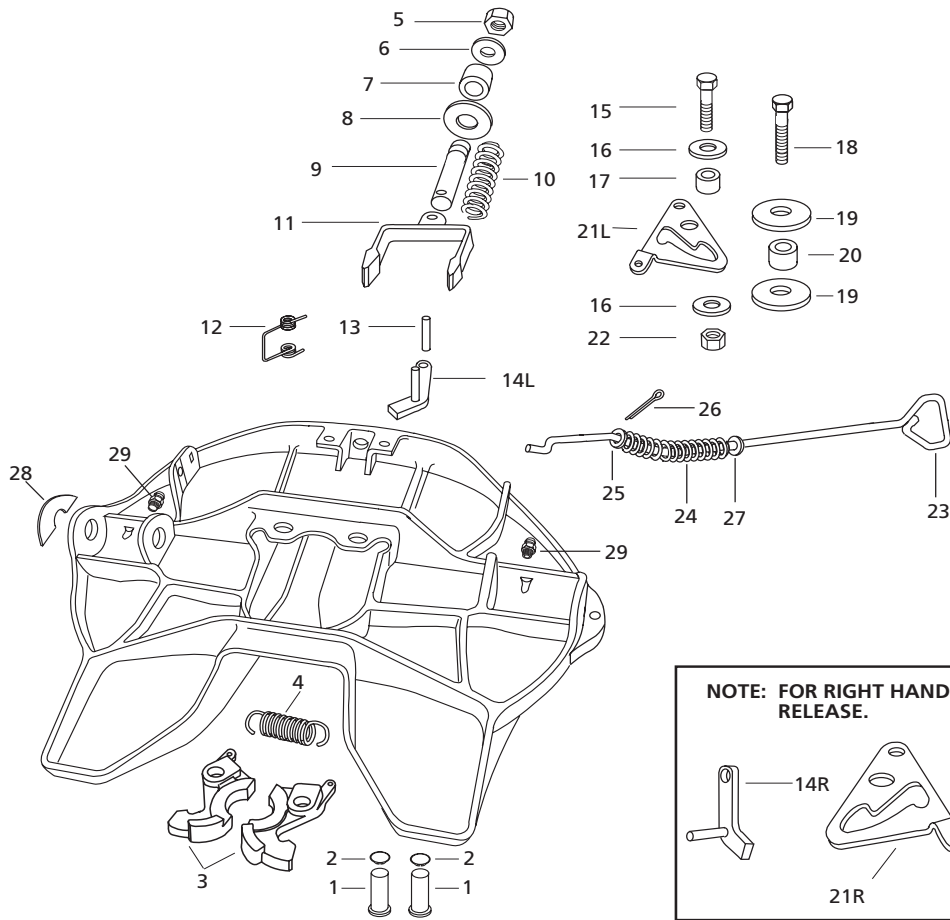

ITEM NO.	PART NO.	NO. REQ.	PART NAME	ITEM NO.	PART NO.	NO. REQ.	PART NAME
1	XA-07292-1	2	Lock pin	21L	XA-07150-L	1	Cam plate (left-hand)
2	XB-07398	2	Retaining ring	21R	XA-07150-R	1	Cam plate (right-hand)
3	XA-07296	1	Lock jaw set	22	XB-T-69-A	1	Locknut (1/2"-20) (2 add'l. req'd. for brackets)
4	XB-07628	1	Extension spring	23	XA-07151-1	1	Release handle (universal for both left and right)
5	XB-HNH-34-F	1	Locknut (3/4"-16)	24	XB-07291	1	Compression spring
6	XB-PW-1316-112	1	Washer (1-1/2" O.D. x 13/16" I.D.)	25	XB-PW-1732-1-116	1	Washer (1-1/16" O.D. x 5/8" I.D.)
7	XB-1127	1	Rubber washer	26	XB-07508	1	Cotter pin (1/8" x 1-1/4")
8	XB-02312	1	Lock adjustment tag	27	XB-T-49	1	Washer (1-3/8" O.D. x 9/16" I.D.)
9	XA-1706	1	Yoke shaft	28	XB-07610	1	Operation tag
10	XB-1505	1	Compression spring	29	XB-H-38	2	Grease zerk
11	XA-07295	1	Yoke	* 30	XB-C-95	2	Hex head cap screw (1/2"-20 x 1-1/4")
12	XB-2149	1	Torsion spring	* 31	XE-06356	2	Bracket pin
13	XB-21-S-500-2750	1	Roll pin (1/2" x 2-3/4")	* 32	XB-1604-5	2	Rubber bushing (brackets mfg'd prior to 5/82)
14L	XA-3542-L	1	Secondary lock (left-hand)	* 33	XB-0011-2	2	Rubber bushing (brackets mfg'd after 5/82)
14R	XA-3542-R	1	Secondary lock (right-hand)	** 34	XA-3542-M	1	Manual secondary lock release handle
15	XB-2083	1	Hex head cap screw (1/2"-20 x 1-3/4")	** 35	XA-3528	1	Manual secondary lock
16	XB-08559	2	Washer (1-3/4" O.D. x 9/16" I.D.)	* 36	TF-0110	1	Kingpin gage
17	XA-1029	1	Roller (1/2" I.D.)	* 37	TF-0237	1	2" Lock gage (plug)
18	XB-CX-58-F-134	1	Hex head cap screw (5/8"-18 x 1-3/4")	* 38	TF-TLN-5001	1	Kingpin lock tester (New)
19	XB-07431	2	Washer (2-5/8" x 21/32")	* 39	TF-TLN-1000	1	Kingpin lock tester (Old)
20	XA-1507	1	Roller (5/8" I.D.)				

* Parts not included in rebuild kit (available from your local Holland distributor.)

** Parts included in rebuild kits RK-351-A-L-02 and RK-351-A-02.