

The Holland logo consists of the word "Holland" in a white, italicized, sans-serif font, enclosed within a white oval shape. This oval is set against a black rectangular background.

OWNER'S MANUAL

FW8 and XA-201 FleetMaster Fifth Wheel

Installation, Operation,
Maintenance Procedures and
Comprehensive Warranty



Questions or Comments?
Call **1-888-396-6501**

www.safholland.us

INSTALLATION INSTRUCTIONS





General Safety Information

It is important to read, understand, and follow the important information contained in these installation instructions. Failure to do so may result in a hazardous condition or cause a hazardous condition to develop.

All welding should be performed by an AWS certified welder using a low hydrogen process and AWS E70XX filler metal. Failure to weld correctly may cause distortion, damage, and/or result in insufficient strength and subsequent joint failure which, if not avoided, could result in death or serious injury.

Prior to welding take precautions to ensure that the tractor electrical system is not damaged due to the welding process.

Safety Signal Words

- | | |
|--|--|
|  | DANGER indicates an imminently hazardous situation which, if not avoided, will result in death or serious injury. |
|  | WARNING indicates a potentially hazardous situation which, if not avoided, could result in death or serious injury. |
|  | CAUTION indicates a potentially hazardous situation which, if not avoided, may result in minor or moderate injury. |
|  | CAUTION used without the safety alert symbol indicates a potentially hazardous situation which, if not avoided, may result in property damage. |

1. **Keep Work Area Clean.** Cluttered areas and benches invite accidents.
2. Keep fingers away from all potential pinch points in the fifth wheel.
3. All fifth wheel maintenance must be performed by a qualified service technician using proper tools and safe procedures.
4. Use only SAF-HOLLAND original parts.
5. **Use Safety Goggles.** Glasses or goggles not in compliance with ANSI or CSA can cause serious injury when damaged or broken.
6. **Wear Proper Apparel.** Do not wear loose clothing, gloves, neckties, jewelry (rings, wristwatches, etc.) that can get caught in moving parts. Non-slip footwear is recommended.

Fifth Wheel Design and Intended Use:

1. For pulling trailers with standard SAE kingpins which are in good condition and securely mounted or locked in position in the trailer.
2. For on-highway hauling applications.
3. Within the capacities stated in SAF-HOLLAND literature.
4. As recommended in SAF-HOLLAND literature (available from www.safholland.us).

Holland Fifth Wheels are NOT Designed or Intended For:

1. Use with non-SAE kingpins, such as kingpins which are bent, improper size or dimensions, not secured to maintain SAE configuration, or which are installed in warped trailer bolster plates.
2. Tow-away operations which damage or interfere with the proper operation of the fifth wheel.
3. The attachment of lifting devices.
4. The transport of loads in excess of rated capacity.
5. Off-highway applications and use.
6. Applications other than recommended.

Installation

General Recommendations

1. Every user and installer using SAF-HOLLAND products either recommended or not recommended by SAF-HOLLAND, must thoroughly satisfy himself that the installation procedure used is appropriate for the vehicle, product and application.
2. Consult the SAF-HOLLAND literature for fifth wheel capacities and applications.
3. Consult the tractor manufacturer's body builder's book and the latest SAE and D.O.T. standards for additional installation methods. SAF-HOLLAND recommends the *T.M.C. Recommended Maintenance Practice 603* for installation procedures.
4. Determine the proper fifth wheel position, or, in the case of a sliding fifth wheel, the range of proper positions. Proper positioning of the fifth wheel is important for weight distribution, swing clearance and handling characteristics. See SAE J701 for proper placement, as well as the tractor manufacturer's body builder's book.
5. Use only new Grade 8, 5/8" minimum diameter bolts and new Grade "C" locknuts in all mounting holes. Larger diameter Grade 8 fasteners may be used.
6. Bolt holes can be 1/32" larger in diameter than the fastener. Bolts must be adequately tightened to manufacturer's torque recommendation.
7. The bolts attaching the fifth wheel mounting angles to the tractor frame require hardened steel washers under both the bolt and under the locknut, unless flanged head bolts or flanged head locknuts are employed.
8. A minimum of 5 bolts are required to attach each stationary mounting angle and a minimum of 6 bolts are required to attach each sliding fifth wheel to the frame rail. The distance between bolts must not exceed 8", except when cutouts are required in the mounting angles. When attaching an outboard angle to the fifth wheel slide plate, all mounting holes are to be used on each side.
9. Whenever a cutout is made on the mounting angle, such as required to bypass spring hangers, a 1" minimum radius should be used and bolts should be placed within 1-1/2", but not closer than 1" of the cut, fore and aft.
10. The mounting angle should have a minimum thickness as shown in **TABLE 1** and should be steel specification ASTM A 36.

11. When initially positioning the fifth wheel for frame holes, the full length of the fifth wheel or slider mounting angles should seat flush on the top and side surface of the truck-tractor frame rails where channel-type rails are employed. There should not be a gap over the top of the truck frame rails. The base of the fifth wheel assembly and of the mounting angle members should seat flush on the top of the frame rail to prevent flexing and to give uniform weight distribution. It is also recommended to chamfer or smooth sharp edges and corners of mounting materials wherever contact is made with the tractor frame.

TABLE 1		
Fifth Wheel Vertical Capacity	Minimum Mounting Angle Thickness	Minimum Mounting Plate Thickness
12,000 lbs.	1/4"	1/4"
20,000 lbs.	5/16"	1/4"
40,000/45,000 lbs.	5/16"	5/16"
50,000/55,000 lbs.	3/8"	3/8"
62,500/70,000 lbs.	1/2"	1/2"
100,000 lbs.	3/4"	3/4"
165,000 lbs.	3/4"	1"

12. If the fifth wheel is to be mounted using a mounting plate (bracket with mounting base), refer to **TABLE 1** for minimum plate thickness recommendations.

⚠ WARNING

Do not use U-bolts in fifth wheel installations. Use only new Grade 8, 5/8" minimum diameter bolts and new Grade C lock nuts in all mounting holes.

Failure to do so may result in structural failure of the installation with a potential loss of the fifth wheel assembly, mounting structure, and/or trailer, which, if not avoided, could result in death or serious injury.

13. Trailer pick-up ramps are recommended at the rear of the truck-tractor frame.
14. When mounting to aluminum frames, follow the tractor manufacturer's recommendations. SAF-HOLLAND has available a stationary mounting angle intended for use with aluminum frames. Contact SAF-HOLLAND or distributors of Holland brand products for availability.
15. Review, in addition, the specific information on the following pages for each type of fifth wheel mounting, as well as "Inspection and Lubrication Prior to Use" on page 11 of this publication.

INSTALLATION INSTRUCTIONS continued

NOTE: The full length of the fifth wheel mounting angle should seat flush on the tractor frame to prevent flexing of mounting angle and to give uniform weight distribution along the frame rail.

Stationary Fifth Wheel Installation

Prior to proceeding with the installation of the stationary fifth wheel assembly, carefully review the "General Safety Information" section on page 2.

Angle Mount

(see Figure 1A and 1B):

Holland standard Angle Mount fifth wheels are provided with the mounting bracket welded in the center of a standard 4" x 4" x 36" long angle for a specific frame width dimension. Various heights, frame widths, and angle sizes are available.

In addition to the information given in "Installation: General Recommendations" on page 3, the following sequence should be followed when installing your angle mount fifth wheel:

1. Verify the distance between the mounting angles and tractor frame width to insure a proper fit when the fifth wheel is installed on the tractor.
2. Reference **FIGURE 1B** for proper mounting hole location requirements.
3. Securely position the mounting angle to the tractor frame.
4. Bolt the angles to the tractor frame following the recommendations in **FIGURE 1A**.

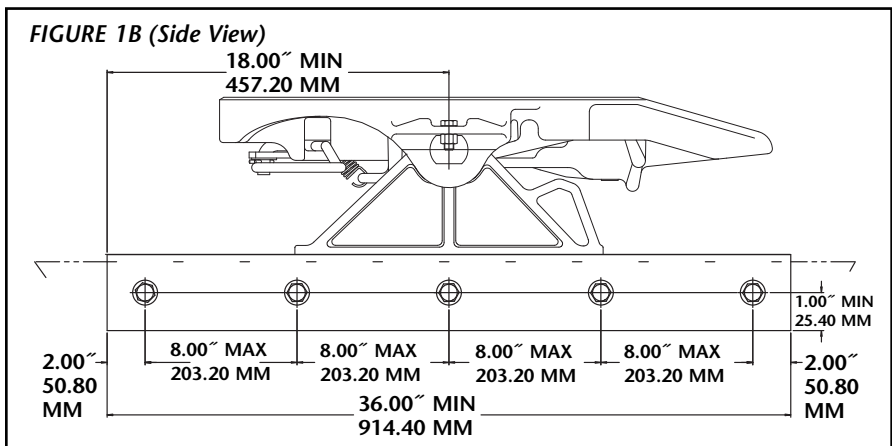
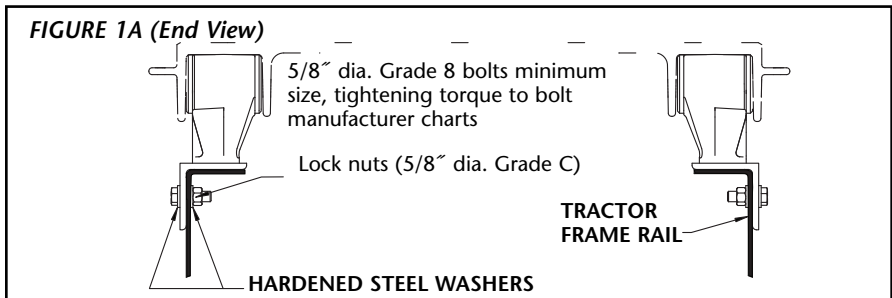

Stationary Fifth Wheel Installation *continued*

Foot Mount

(see Figures 1B, 1C, 1D and 1E):

Holland Foot Mount fifth wheels are an outboard mount application intended for installation on flat or corrugated mounting plate.

In addition to the information given in "Installation: General Recommendations" on page 3, the following sequence should be followed when installing your foot mount fifth wheel:

1. Bolt the outboard mounting angle to the truck frame following the recommendations in **FIGURE 1C**. The top of the mounting angle must be flush with the top of the tractor frame. The mounting angle should be 1" longer than the mounting plate. The minimum angle size requirements are as follows: 3" horizontal leg, 3-1/2" vertical leg, & 36 inches long. For angle thickness and material requirements see "Installation: General Recommendations" on page 3.
2. Reference **FIGURE 1B** for proper mounting hole location requirements.
3. Securely position the mounting plate and fifth wheel on the outboard mounting angles.
4. Bolt the mounting plate and fifth wheel to the outboard angle as shown in **FIGURES 1D**, and **1E**.

FIGURE 1C

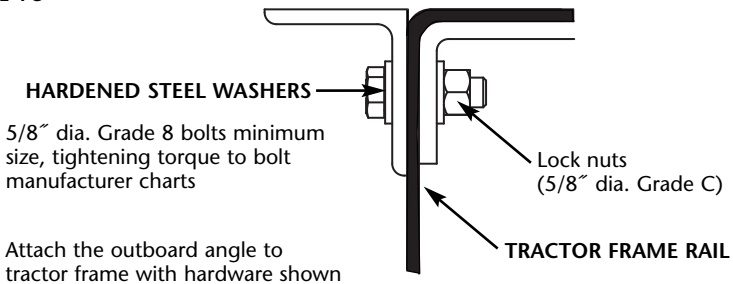
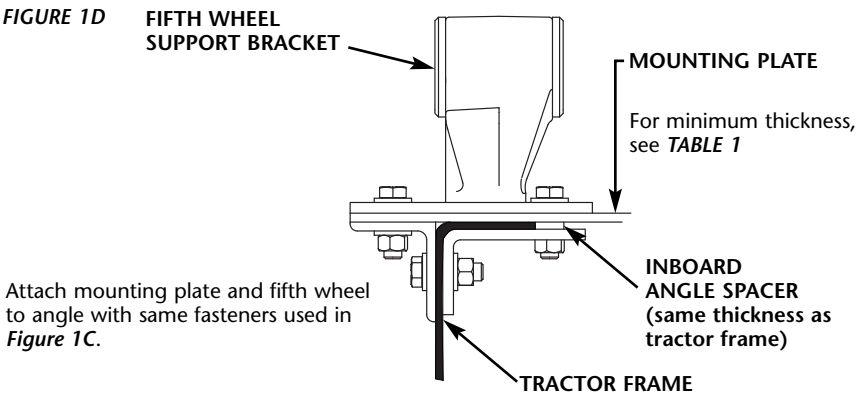

FIGURE 1D



Stationary Fifth Wheel Installation *continued*

Foot Mount *continued*

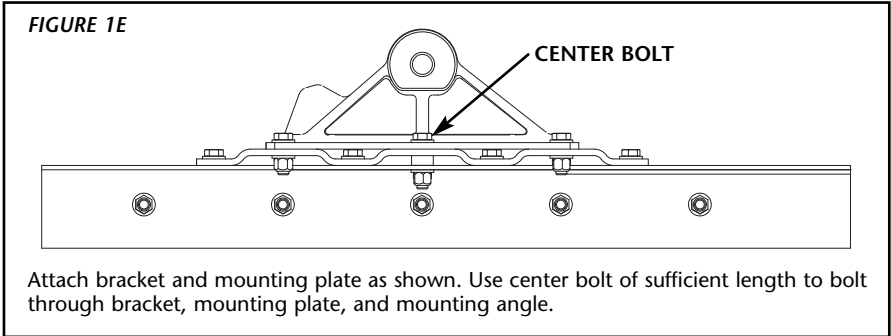

Plate Mounting

(See Figures 1C and 1F):

Holland Plate Mount fifth wheels are a reduced weight outboard mount application intended for installation directly on mounting angles.

In addition to the information given in "Installation: General Recommendations" on page 3, the following sequence should be followed when installing your plate mount fifth wheel:

1. Bolt the outboard mounting angle to the tractor frame following the recommendations in **FIGURE 1C**. The top of the mounting angle must be flush with the top of the tractor frame. The mounting angle should be 1" longer than the mounting plate. The minimum angle size requirements are as follows: 3" horizontal leg, 3-1/2" vertical leg, & 36 inches long. For angle thickness and material requirements see "Installation: General Recommendations" on page 3.
2. Reference **FIGURE 1B** for proper mounting hole location requirements.
3. Securely position the fifth wheel on the outboard mounting angles.
4. Bolt the fifth wheel to the outboard angle as shown in **FIGURE 1F**.

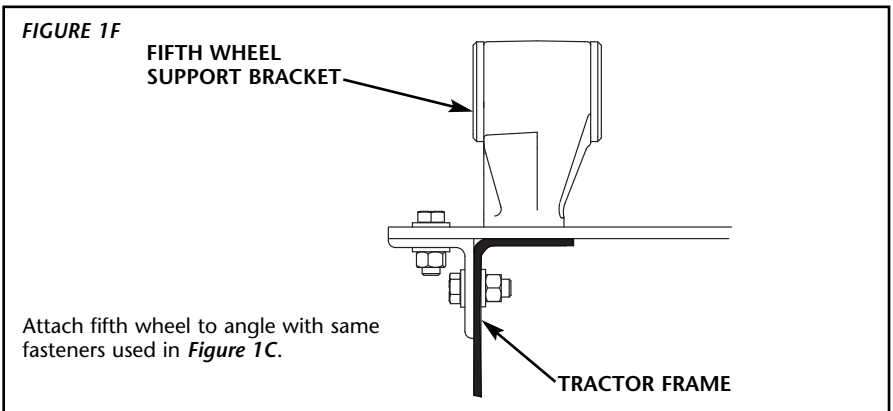

Stationary Fifth Wheel Installation *continued*

Bracket Only Mount

(See Figures 2A, 2B and 2C):

Holland Bracket Only Mount fifth wheels are a weld on product that can be mounted in a variety of configurations. The following is the recommended procedure for welding the variations of standard over the road bracket applications.

1. Review **FIGURES 2A, 2B,** and **2C** for the specific bracket used in your application. Follow the recommended welding procedure shown.
2. For angle fabrication the mounting angle should extend a minimum of 18" forward and not less than 12" to the rear of the pivot point. Minimum angle length is 36".
3. Brackets need to be positioned so that the fifth wheel can be properly mounted on the brackets when secured to the tractor frame.
4. For angle thickness see "General Recommendations" on page 3 (**TABLE 1**).
5. For installation after welding follow the stationary fifth wheel mounting instruction for the mounting style that applies.

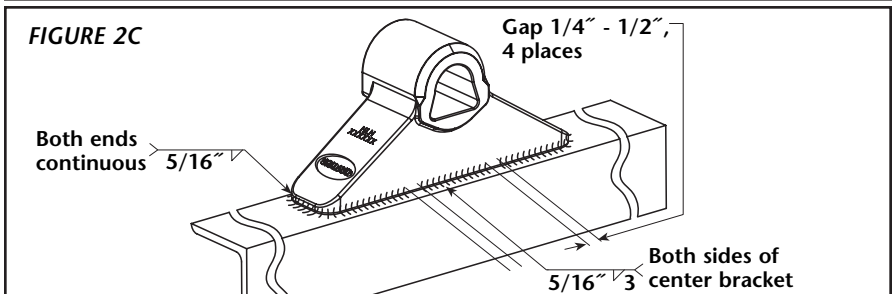
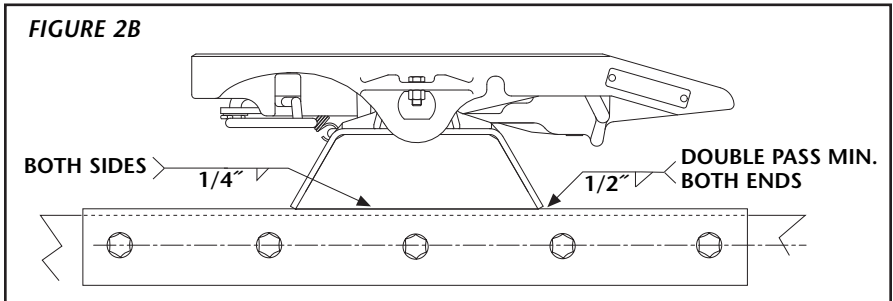
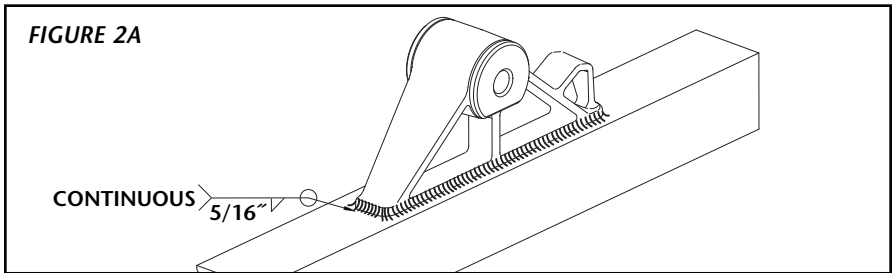

Sliding Fifth Wheel Installation - ILS Slider

Prior to proceeding with the installation of the sliding fifth wheel assembly, carefully review the “General Safety Information” section on page 2.

Inboard Angle Mounting

(See Figures 3 and 4):

- Angles must be installed on the sliding fifth wheel base plate to facilitate mounting. See “Installation: General Recommendations,” on page 3, for angle thickness and material.
- Use a mounting angle which is at least 2” longer than the slide base, 36” minimum length, and 3-1/2” minimum vertical leg size. For horizontal leg size, see TABLE 2. The fifth wheel top plate may be removed from the base plate for ease of handling.
- Position the angles on the slide plate for the required frame width. Be sure to keep the plate centered left to right, and front to rear on the mounting angles.
- Weld as shown in FIGURE 3. Outside welds to have a 3/8” fillet weld placed either on or between the tabs, depending on frame width. Inside welds to be 3/8” fillet weld alternating with the outside welds so that they are staggered along the angle. Also weld the fifth wheel base plate to the top of the angle at the ends of the plate as shown in FIGURE 3.
- Attach the slider plate and mounting angles to the tractor using recommendations in “Installation: General Recommendations,” on page 3 and in FIGURE 4.
- Reassemble the fifth wheel top plate to the slider base plate, if it was removed previously.

Frame Width Dimension (Inches)	Angle Horizontal Leg Size (Inches)
33-1/4” - 33-1/2”	3”
33-5/8” - 34-1/2”	3-1/2”
34-5/8” - 35”	4”

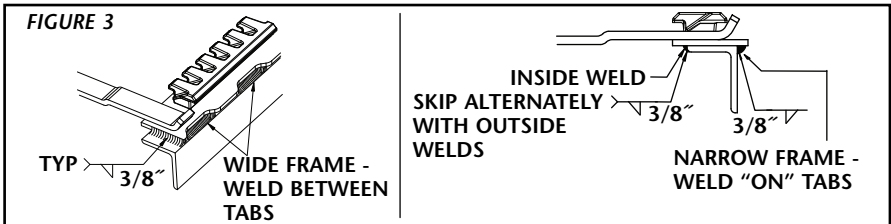

Sliding Fifth Wheel Installation - ILS Slider continued

Inboard Angle Mounting continued

(See Figures 3 and 4):

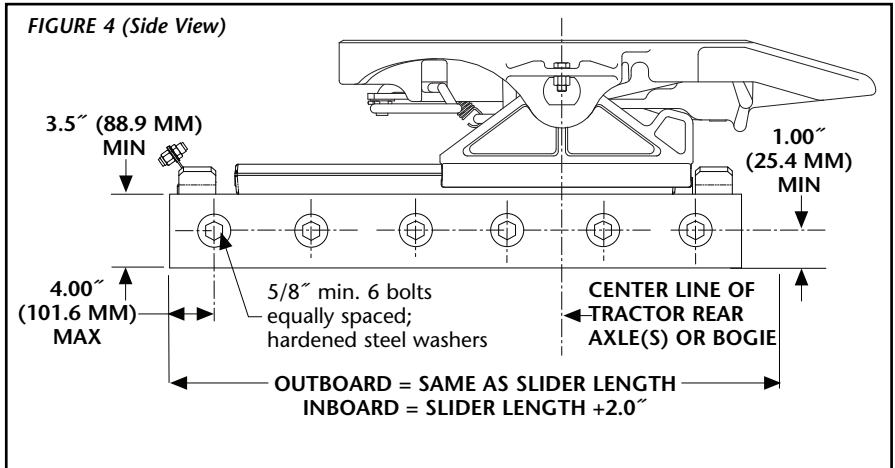

Outboard Angle Mounting

(See Figures 5A and 5B):

1. If angles are not installed, see "Installation: General Recommendations," on page 3, for thickness and material. Use 3" minimum horizontal and 3-1/2" minimum vertical leg size. Longer horizontal legs may be required with narrow frame widths. The recommended length of each mounting angle is the same length as the slide base mounting plate.
2. In addition to the information given in "Installation: General Recommendations," on page 3, follow the recommendations in **FIGURE 5A**. The following sequence is suggested:
 - A. Securely position the mounting angles to the tractor frame and attach as shown in **FIGURE 5A**. Follow the bolting recommendations as shown in **FIGURE 4**. Angles must be flush with the top of the truck frame.
 - B. Locate the slide base and center left to right and front to rear on the mounting angle. **FIGURE 5B** depicts distance from fifth wheel centerline to last mounting hole, when fifth wheel is in full rear position. Clamp in place and drill 21/32" diameter holes using the mounting plate as a template if holes are not provided in the angle.
 - C. Align holes in the slide plate with outboard angle mounting holes and bolt using Grade 8 fasteners, hardened steel washers and Grade C locknuts, properly tightened, (see **FIGURE 5A**). Use all mounting holes on the fifth wheel.

NOTE: Tighten center nut, then alternate nuts on either side, beginning with end nuts.

INSTALLATION INSTRUCTIONS *continued*

Sliding Fifth Wheel Installation - ILS Slider *continued*

Outboard Angle Mounting

(See Figures 5A and 5B):

FIGURE 5A

The full length of the fifth wheel mounting angle should seat flush on the truck frame to prevent flexing of mounting angle and to give uniform weight distribution along truck frame rail.

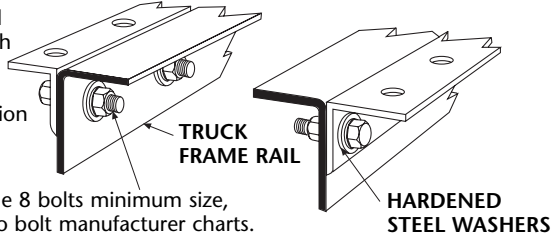

5/8" diameter Grade 8 bolts minimum size, tightening torque to bolt manufacturer charts.
Hardened steel washers or flanged locknuts.
5/8" diameter Grade C locknuts.

FIGURE 5B

8.25"
(209.55 MM)
FULL REAR

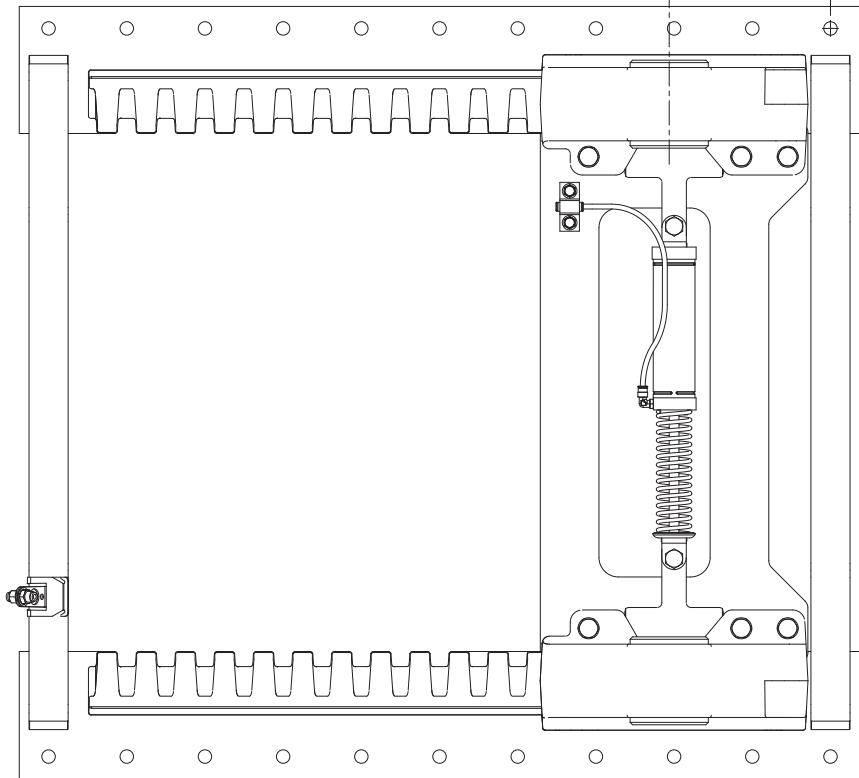

Sliding Fifth Wheel Installation - ILS Slider *continued*

Attachment of Air-Activated Slide Release – If Required

1. Mount the cab control valve in accordance with the instructions provided. It should be readily accessible to the driver, but protected to prevent accidental activation.
2. Attach an air line, using appropriate fittings to the “air” or “in” port of the valve. Use an air source recommended by the tractor manufacturer. Use fittings and lines of suitable pressure rating.
3. Make sure that the air supply to the fifth wheel and slide base is turned off.
4. Remove any masking that may be present on the bulkhead and union fittings.
5. Connect the coiled air line by pushing it into the union fitting as shown in **FIGURE 6**.
6. Connect the other end of the coiled air line by pushing it into the bulkhead fitting on the standoff as shown in **FIGURE 7**.
NOTE: If there are any air line interferences, the bulkhead fitting can be repositioned using an optional hole in the standoff.
7. Turn on the air supply to the fifth wheel and slide base; check for proper function.

FIGURE 6

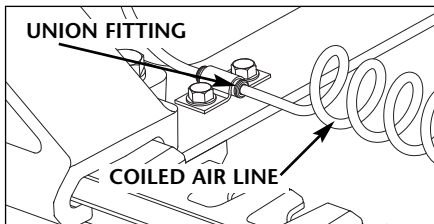
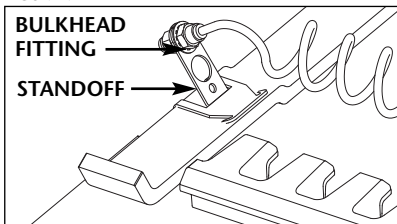

FIGURE 7



Inspection and Lubrication Prior to Use

1. Review the installation. Be sure all nuts and bolts are in place and properly tightened. Be sure all necessary steps were properly followed and that all components removed to facilitate installation are reinstalled.
2. Check the fifth wheel locking mechanism with a Holland TF-TLN-5001 (2") or TF-TLN-1500 (3-1/2") Lock Tester. Examine for proper locking as described in the "Operating Instructions" of this manual. This must be done to assure that the mechanism has not been damaged by shipment, handling, or storage.

⚠ WARNING

Failure to properly install, operate, or maintain this fifth wheel may result in tractor and trailer separation which, if not avoided, could result in death or serious injury.

3. Apply a generous coating of grease to the top of the fifth wheel plate, where it will contact the trailer plate.
4. Apply a generous coating of grease to the front lock and lock jaws.

OPERATING INSTRUCTIONS

WARNING You must read and understand the following instructions before operating your fifth wheel.

Failure to follow all the operating procedures contained in these instructions may result in a hazardous condition or cause a hazardous condition to develop.

These instructions apply to the proper operation of your fifth wheel only. There are other important checks, inspections, and procedures not listed here that are necessary, prudent, and/or required by law.

Coupling Procedures

1. Inspect the fifth wheel mounting.

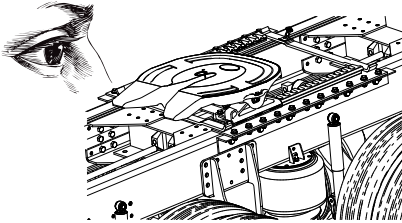

- Tighten loose fasteners
- Replace missing fasteners
- Repair/replace cracked components

If you have a sliding fifth wheel, make sure both plungers are fully engaged.

2. Make sure coupling area is flat, level and clear of persons and obstacles.

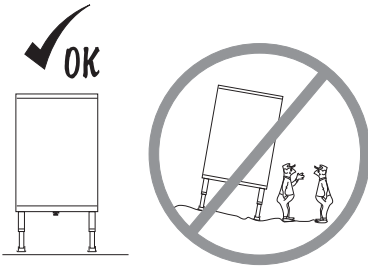

3. Lubricate the fifth wheel-to-trailer contact surface with grease. Tilt the ramps down.

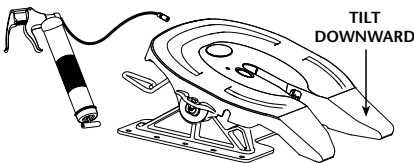

4. Make sure the locks are open. To open locks, slide the handle forward and pull it out to the maximum extension. The lock will swing to the open position.

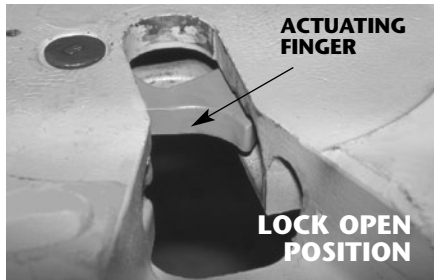

TO OPEN LOCK

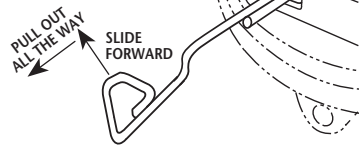

5. Center kingpin with fifth wheel.

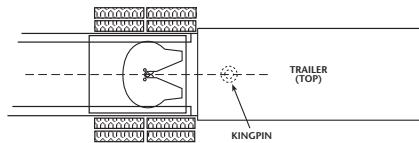

6. Back tractor close to trailer and **STOP**.

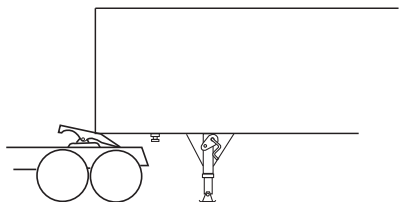

Coupling Procedures *continued*

7. Chock trailer wheels.
8. Connect brake lines and light cord.
9. Support slack in lines to prevent interference.
10. Set trailer brakes.
11. Adjust trailer height so fifth wheel will lift trailer. Trailer should contact fifth wheel 4" - 6" behind fifth wheel bracket pin.

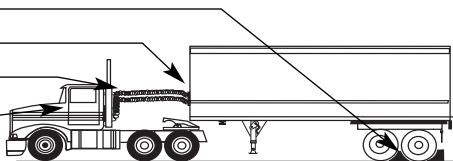

⚠️ WARNING Attempting to couple with the trailer at an improper height may result in a false or improper coupling, allowing tractor and trailer separation, which, if not avoided, could result in death or serious injury.

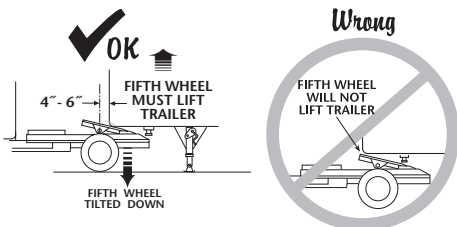

12. Slowly back into trailer.
13. Do a pull test as an INITIAL CHECK.
14. Visual inspection.

Get out of the tractor.

Visually check that the lock is CLOSED!

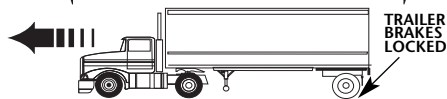

⚠️ WARNING An improperly coupled tractor and trailer may separate while in use which, if not avoided, could result in death or serious injury.



⚠️ WARNING Do not use any fifth wheel that fails to operate properly. Failure to properly couple tractor and trailer may cause separation which, if not avoided, could result in death or serious injury.

If you do not obtain a proper couple, repeat the coupling sequence.

15. Retract landing gear until pads come off the ground.
16. Follow instructions published separately for safe operation of the trailer to fully retract landing gear and secure crank handle.
17. Re-check brake lines and light cord. Remove wheel chocks, continue with pre-trip inspection.

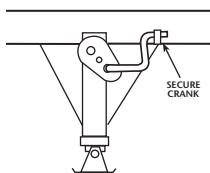
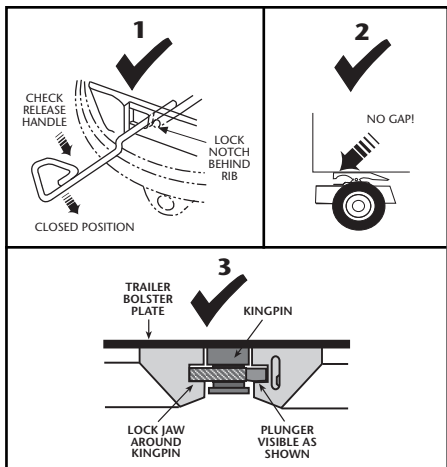

continued

OPERATING INSTRUCTIONS *continued*

Coupling Procedures *continued*



Do not operate the vehicle without fully retracting the landing gear. Failure to fully retract the landing gear to attain sufficient

ground clearance for transit may result in damage to the landing gear or components which, if not avoided, could result in death or serious injury.

Uncoupling Procedures

1. Position tractor and trailer on firm, level ground clear of obstacles and persons.
2. Set trailer brakes.
3. Slowly back tractor tightly against trailer.
4. Set tractor brakes.
5. Chock trailer wheels.
6. Lower landing gear until pads just touch the ground. (**NOTE:** Follow instructions published separately for safe operation of the trailer to transfer trailer weight off fifth wheel. Do not raise trailer off the fifth wheel.)
7. Disconnect brake lines and light cord. Attach brake line to dummy coupling to keep line clean.
8. If equipped, pull secondary lock handle and hook on casting (located on left/road side of fifth wheel).
9. Pull primary release handle.
10. Release tractor brakes and slowly drive away from trailer. Let the trailer slide down the fifth wheel and pick-up ramps, being careful that the trailer landing gear touch the ground with minimal impact.

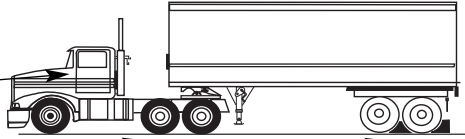

PRIMARY
RELEASE HANDLE

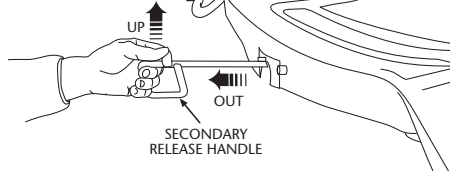

UNLOCK
NOTCH

3rd
2nd
1st

LOCK NOTCH

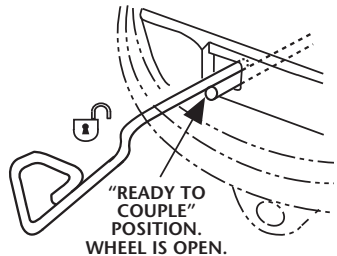

NOTE: It is normal after uncoupling for the release handle to come off the unlock notch and move to a "ready to couple" position.

Fifth Wheel Slide Adjustment for ILS Sliders

1. Position tractor and trailer in a straight line on level ground.
2. Lock the trailer brakes.

CAUTION

The trailer must be stopped and the trailer brakes locked to prevent damage to the tractor or trailer by uncontrolled sliding of the fifth wheel.

3. Release slide locking plungers.
4. Move cab switch to unlock position.

NOTE:

Switch style may differ by OEM design.

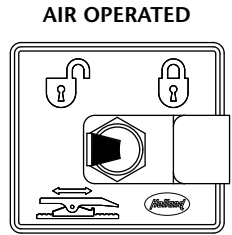

Move cab switch to unlock position.

5. Slowly drive the tractor forward or backward to position the fifth wheel.
6. Re-engage the slide locking plungers. Verify that plungers have engaged by performing a tug test.

NOTE: Retract landing gear if lowered.

NOTE:

Switch style may differ by OEM design.

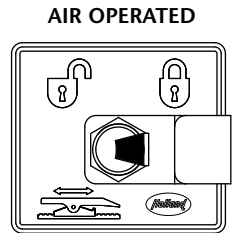

Move cab switch to lock position.

7. Do a pull test to make sure plungers are properly engaged and locked into the slide base.

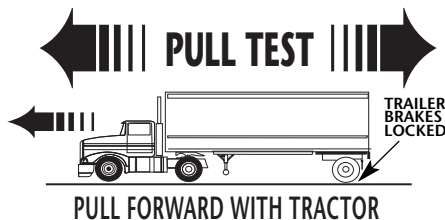

WARNING

Do not operate the vehicle if the plungers are not fully engaged (locked). Failure to properly engage plungers and slide base may cause loss of vehicle control which, if not avoided, could result in death or serious injury.

MAINTENANCE PROCEDURES

⚠WARNING You must read and understand the following instructions before operating your fifth wheel.

All maintenance must be performed by a qualified person using proper tools and safe procedures. All maintenance must be performed while the tractor is uncoupled from the trailer.

Failure to follow all the maintenance procedures contained in these instructions may result in a hazardous condition or cause a hazardous condition to develop which, if not avoided, could result in death or serious injury.

As-Needed and Periodic Lubrication

1. **IMPORTANT!** Always maintain adequate lubrication in fifth wheel locking mechanism. Relube as necessary (see *Figure 1*).
2. Keep a low temperature, water resistant lithium grease applied to the trailer contact surface of the fifth wheel.

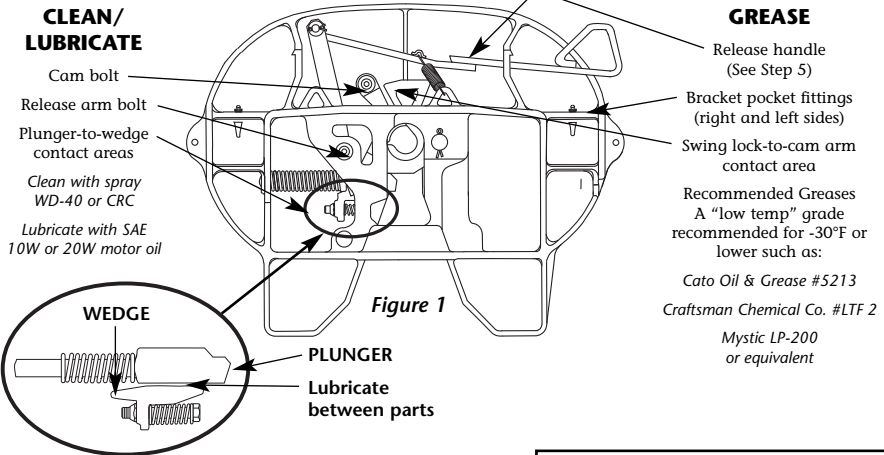

3. Grease the support bracket pockets through the grease fittings on the front of the fifth wheel bracket pockets (lift up slightly on the fifth wheel plate when applying grease).

4. **For fifth wheels with sliding brackets:** Release and slide fore and aft to assure entire mechanism functions properly. Apply an aerosol spray lubricant or soap to the slide path. Apply Never-Seez™ to the plunger and its moving parts. Reposition and lock sliding mechanism.

5. Inspect the release handle. If your fifth wheel is a **RIGHT HAND** (curb side) release, apply grease along the release handle where it contacts the handle spring (see *Figure 1a*). If you have a **LEFT HAND** (driver side) release handle with a sliding spring, as shown in *Figure 1b*, apply grease along the release handle where it contacts the handle spring. Lubrication is **NOT** required for **LEFT HAND** (driver side) release handles that **HAVE** a fixed spring (see *Figure 1c*).

6. Check the operation by locking and unlocking using a Holland TF-TLN-5001 Lock Adjustment Tool. Verify that the fifth wheel is completely closed, as shown in *Figure 3A* on page 17.

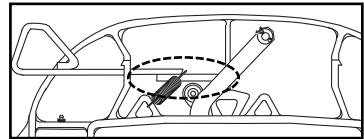

Right Hand Release with Sliding Spring
(Grease Required)

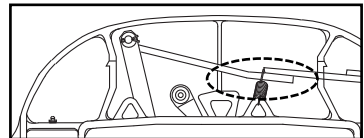

Left Hand Release with Sliding Spring
(Grease Required)

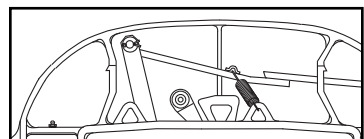

Left Hand Release with Fixed Spring
(No Grease Required)

Do not use any fifth wheel that does not operate properly. If your fifth wheel does not operate properly, DO NOT USE IT!

⚠️WARNING Failure to properly couple tractor and trailer may cause separation which, if not avoided, could result in death or serious injury.

If your fifth wheel does not operate properly, contact your nearest SAF-HOLLAND representative for assistance.

Required Inspections and Adjustments

Perform the following every six months or 60,000 miles, whichever comes first. Thoroughly steam clean all components before inspecting or adjusting.

General Fifth Wheel Inspection:

1. Inspect the fifth wheel mounting. Check torque and replace any missing or damaged bolts. Check for broken, worn or damaged parts, replace as needed.
2. Thoroughly clean the fifth wheel locking mechanism every 6 months or 60,000 miles and relubricate (see *Figure 1* on page 16). Re-check operation with TF-TLN-5001 Lock Adjustment Tool.
3. Inspect the fifth wheel for bent, worn or broken parts. Replace with only Holland Genuine Parts.
4. Make sure the bracket pin retention bolts and locknuts are in place and tight, as shown in *Figure 2*.

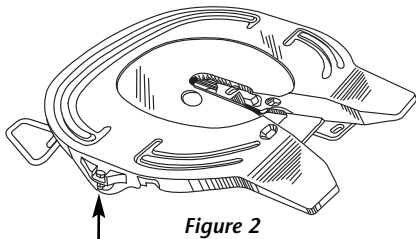

Make sure bolt and nut are in place and tight (both sides).

Inspection – Locking Mechanism

1. Check the operation of the fifth wheel locking mechanism using a Holland TF-TLN-5001 (2" kingpin) Lock Adjustment Tool. Inspect for proper locking as described in the "Fifth Wheel Operating Instructions" section of this manual.
2. **IMPORTANT!** The lock is properly closed when:

Figure 3A

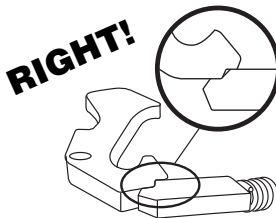
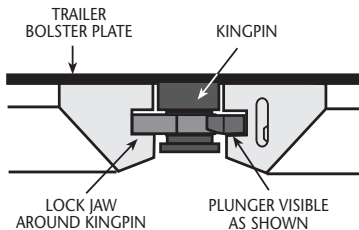

Figure 3B

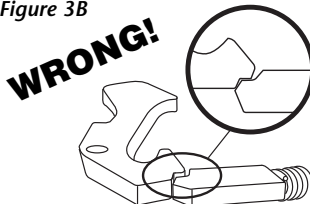
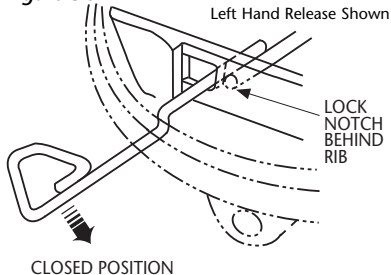

Figure 3C



Adjustment – Locking Mechanism:

1. Using **ONLY** a Holland TF-TLN-5001 Lock Adjustment Tool, lock the fifth wheel.
2. **Check the plunger – it must be visible behind the lock and engaged on both steps**, as shown in *Figure 3A*. If the plunger is not visible or not engaged on both steps (*Figure 3B*), turn the adjustment bolt counterclockwise 1/2 turn, then try to lock the locks again.

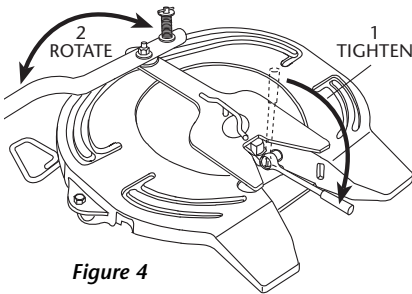

Figure 4

3. **Check the release handle** – it must be fully retracted and the handle lock notch must be behind the rib as shown in *Figure 3C*.
4. Using a 15/16" socket, tighten the locks by turning the lock adjustment bolt clockwise 1/4 turn at a time. Remove the socket wrench from the bolt and rotate the lock adjustment tool, as shown in *Figure 4*, to check for resistance between the lock and lock adjustment tool.
5. Continue to alternate tightening (clockwise) the adjustment bolt 1/4 turn at a time, removing the socket wrench, and rotating the lock adjustment tool until you feel resistance against the lock adjustment tool. Once you begin to feel resistance, **STOP!**

WARNING At this point, the fifth wheel is **OVERADJUSTED** and **NOT** useable. Using an improperly adjusted fifth wheel may cause tractor and trailer separation which, if not avoided, could result in death or serious injury.

6. Loosen the adjustment bolt counterclockwise **TWO FULL TURNS**. The lock is now properly adjusted.
7. Verify this adjustment by locking and unlocking several times using the Lock Adjustment Tool; check for proper locking (See *Figure 3A* and *Figure 3C*).
8. If there is a large amount of fore and aft movement with the adjustment tool when verifying adjustment, check to make sure the lock is engaged in **both** steps (*Figure 2*).

If the lock is only engaged on one step, repeat **Step 2** (above), of the Adjustment Procedure until the lock engages on both steps. (See *Figure 3A*.)

WARNING Improper adjustment can cause improper locking of the fifth wheel. An improperly coupled tractor and trailer may separate while in use which, if not avoided, could result in death or serious injury.

If your fifth wheel does not operate properly, **DO NOT USE IT!** If your fifth wheel does not operate properly, repeat the adjustment procedures or contact your nearest Holland representative for assistance.



HOLLAND FW8 SERIES FIFTH WHEEL NORTH AMERICAN COMMERCIAL WARRANTY

SAF-HOLLAND's Commitment:

We warrant each FW8 and FW83 (LowLube model) fifth wheel (herein referred to as "FW8 Series") manufactured after August 1, 2005, when properly installed on your vehicle and maintained in accordance with our requirements, as follows:

I. Materials and Workmanship:

Our FW8 Series fifth wheels will be free from defects in material and workmanship for five years or 500,000 miles (whichever comes first) when used for approved applications. In approved applications, lube plates (FW83 LowLube model) are warranted for two years or 200,000 miles (whichever comes first).

II. Application Specific Performance

Guarantee:

In addition, when your FW8 Series fifth wheel is used in Standard Duty Applications (as defined below) it will, for five years after the date of your purchase or 500,000 miles (whichever comes first):

1. Operate as described in our FW8 Series operation and maintenance literature;
2. Maintain an acceptable wear limit between the fifth wheel locks and a new SAE J700b kingpin when adjusted in accordance with our FW8 Series maintenance literature.

Standard Duty Applications require that your vehicle:

- 1) operates on highway only; 2) has a maximum gross combined vehicle weight of 95,000 lbs. (including tractor, trailer and cargo); and 3) has a maximum of five axles.
- If any FW8 Series fifth wheel or component part is determined to have a defect in material and workmanship or if it does not perform as warranted in a Standard Duty Application, we will cover the cost to repair or replace the product or part. We will provide a reasonable labor allowance for removal, and repair or replacement, and will provide you with parts or reimburse you for parts at our acquisition cost, provided this does not exceed the suggested list price.

Your Responsibilities:

You are responsible for proper installation, operation and maintenance (including lubrication) as specified in our publications on FW8 Series fifth wheels and for using the product in recommended applications within rated capacities. You are required to obtain prior authorization from us or an authorized customer service representative before replacing or returning any part. You may be required to make the product or part claimed to be covered by this warranty available to us and/or returned to us for review and evaluation.

You may also be required to provide any or all of the following information: vehicle mileage and VIN #, product model # and serial # as shown on the serial tag installed on the product, date of purchase, and application and use information.

Exclusions and Limitations:

This warranty does not cover any FW8 Series fifth wheel or component that fails, malfunctions or is damaged as a result of accident, abuse, improper use, improper installation, intentional modification, corrosion, or failure to provide reasonable maintenance.

THIS WARRANTY IS OUR SOLE WARRANTY IN REGARD TO COVERED FW8 SERIES FIFTH WHEELS. WE MAKE NO OTHER WARRANTIES, EXPRESS OR IMPLIED, OR OF MERCHANTABILITY OR FITNESS FOR A PARTICULAR PURPOSE. IN NO EVENT SHALL WE BE RESPONSIBLE FOR SPECIAL, INCIDENTAL, OR CONSEQUENTIAL DAMAGES OF ANY KIND.

IMPORTANT: Enclosed is important information for the installation, operation, and maintenance of this product. Read and understand this information.



WARNING



FAILURE TO PROPERLY INSTALL, OPERATE, OR MAINTAIN THIS FIFTH WHEEL COULD RESULT IN TRACTOR AND TRAILER SEPARATION CAUSING DEATH OR SERIOUS INJURY TO OTHERS.

CAUTION

OPEN



CLOSED

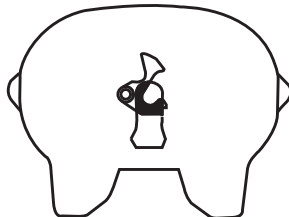

Holland FleetMaster locks are shipped **closed** from the factory. Open the locks before using. Failure to open locks can result in damage to the pin.

TO OPEN LOCKS: Slide the handle forward and pull it out to the maximum extension. The lock will swing to the open position.



SAF-HOLLAND USA, Inc.
888.396.6501 Fax 800.356.3929

SAF-HOLLAND Canada Limited
519.537.3494 Fax 800.565.7753
Western Canada
604.574.7491 Fax 604.574.0244