



FIFTH WHEEL

SIMPLEX BOLT & SPACER REPLACEMENT PROCEDURES



Holland Simplex Fifth Wheel Shoulder Bolt Installation Procedures

INTRODUCTION

These inspection and rework instructions are intended to address coupling difficulties with Simplex fifth wheels related to performance of the lever bar on the fifth wheels when a deformed spacer is present. On affected fifth wheels, the deformed spacer (not visible) may prevent the lever bar from fully articulating, thus preventing the sliding lock from engaging the jaw in the coupled position around the trailer kingpin. This condition is evident to the driver when visually inspecting the release handle and the position of the red indicator in accordance with proper coupling procedures.

Visually inspect the cover plate/lever bar connection on the underside of the fifth wheel. The fifth wheel is affected if a hex-head fastener is used to secure the connection (**FIGURE 1**).

AFFECTED FIFTH WHEELS

All affected Simplex fifth wheels use a hex-head bolt to secure the cover plate/lever bar to the casting as shown in **FIGURE 1**.

FIGURE 1 - AFFECTED UNIT

HEX-HEAD BOLT CONNECTION

SPACER
NOT VISIBLE
LEVER BAR
COVER PLATE
HEX-HEAD BOLT

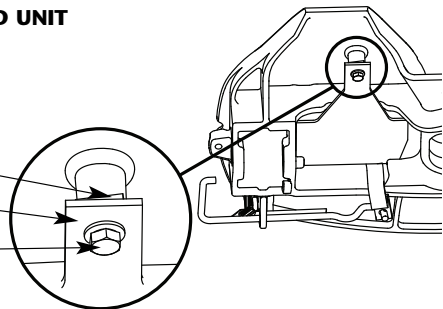

UNAFFECTED FIFTH WHEELS

All unaffected Simplex fifth wheels use a pin to secure the cover plate/lever bar to the casting as shown in **FIGURE 2**.

FIGURE 2 - UNAFFECTED UNIT

PIN CONNECTION

LEVER BAR
NOT VISIBLE
COVER PLATE
CASTING HOUSING
PIN

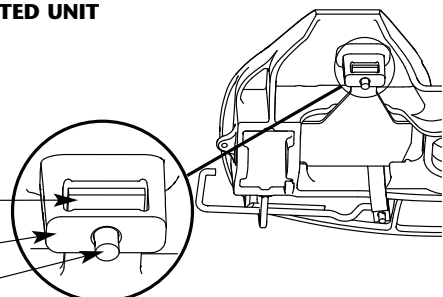

SAFETY INSTRUCTIONS

General Safety Instructions

- **Keep Work Area Clean.** Cluttered areas and benches invite accidents.
- **Keep fingers away from all potential pinch points** in the fifth wheel.
- **All fifth wheel maintenance must be performed by a qualified service technician using proper tools and safe procedures.**
- **Use only Holland Genuine Parts.**
- **Use Safety Goggles.** Glasses or goggles not in compliance with ANSI or CSA can cause serious injury when damaged or broken.
- **Wear Proper Apparel.** Do not wear loose clothing, gloves, neckties, jewelry (rings, wristwatches, etc.) that can get caught in moving parts. Non-slip footwear is recommended.
- **Do not use any fifth wheel that fails to operate properly.**

AIDS TO SIMPLIFY SPACER REMOVAL (NOT INCLUDED)

- 2-1/2" long piece of wood (2" x 4")
- 5/8" diameter rod

PARTS KIT - RK-11131

Check the components of this package. The following parts are included in this kit. If you didn't receive an item, please contact your dealer or distributor.

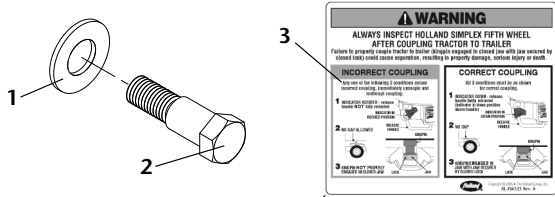

Item	Part Description	PN	Qty.
1	Washer	XB-T-199	1
2	Shoulder Bolt	XB-11127	1
3	Coupling Decal	XL-FW523	1

NOTE: Use parts from one kit to complete one fifth wheel installation.

HOLLAND SIMPLEX SHOULDER BOLT INSTALLATION PROCEDURES

Pre-Disassembly Procedure

NOTE: All fifth wheel maintenance must be performed by a qualified service technician using proper tools and safe procedures.

1. Lock fifth wheel insuring both that the indicator shows a closed lock and that the lock is closed behind the jaw.

NOTE: Lock should be closed using a lock tester or appropriate tool.

2. Pull release handle out about 1" and insert wooden block as shown in **FIGURE 3**.
3. Allow release handle to retract so that the nose of the lock makes contact with the wooden block as shown in **FIGURE 4**.

NOTE: Inserting the wooden block loads the fifth wheel spring with about 25 lbs of pressure, allowing easy alignment of lever bar, lock and fifth wheel casting receptacle.

WARNING Failure to keep fingers away from any pinch points may result in severe hand injuries.

WARNING Failure to wear proper safety goggles during disassembly and assembly may result in eye injuries.

FIGURE 3

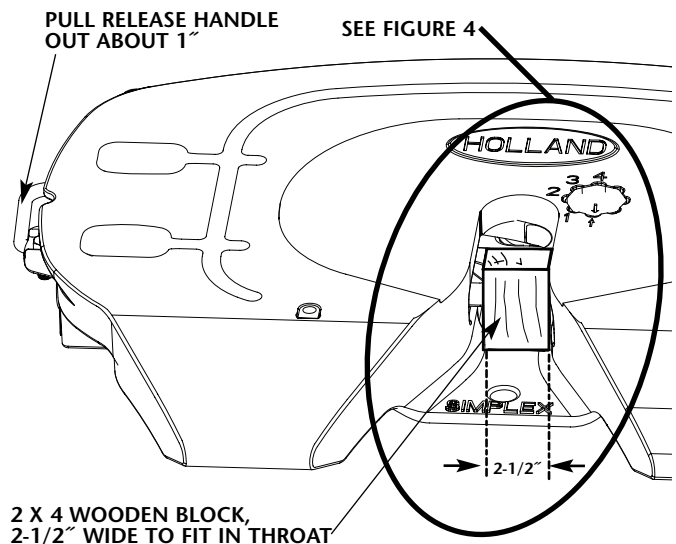
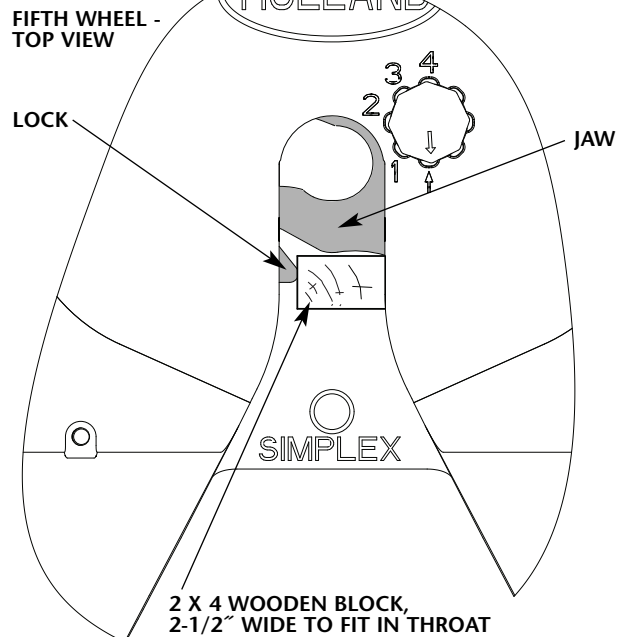

FIGURE 4



HOLLAND SIMPLEX SHOULDER BOLT INSTALLATION PROCEDURES continued

Disassembly of Components

NOTE: The wood block which was inserted in Step 3 of the "Pre-Disassembly Procedure" should remain in place throughout this procedure.

1. Lock fifth wheel insuring both that the indicator shows a closed lock and that the lock is closed behind the jaw.
2. Tilt wheel forward to maximum "ramps up" position for access to bolt as shown in **FIGURE 5**. Wheel should be chocked to hold wheel during repair procedure.

CAUTION Failure to chock fifth wheel in a stable position before performing repair procedures may result in minor or moderate injury.

3. Remove existing bolt and washer from cover plate and discard. See **FIGURE 6**.
4. Remove spacer and discard. See **FIGURE 6**. Spacer may need to be manipulated out of its contact with the lever bar.

NOTE: To make it easier to punch the "spacer" free from the lever bar, use the 5/8" dia. rod.

FIGURE 5

TILT RAMPS UP TO ACCESS COMPONENTS

CHOCK FIFTH WHEEL IN RAMPS UP POSITION

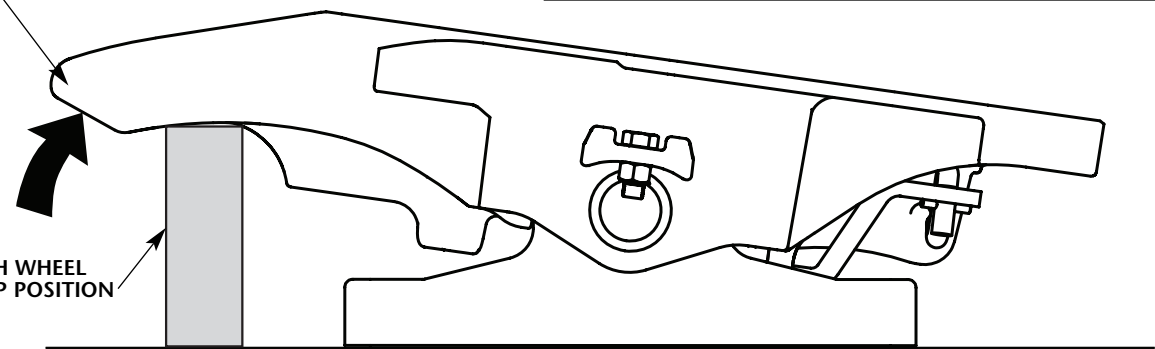

CAUTION Failure to chock fifth wheel in a stable position before performing repair procedures may result in minor or moderate injury.

FIGURE 6

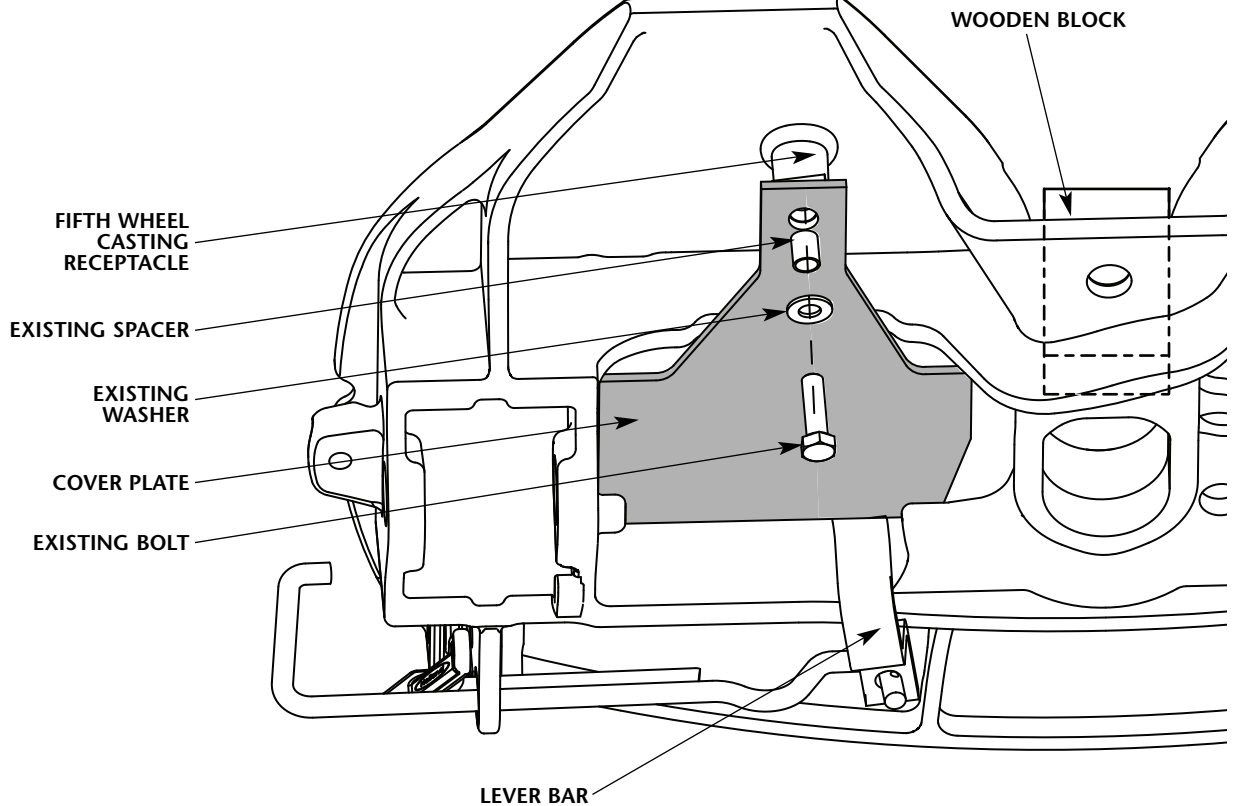

Assembly of New Components

NOTE: The wood block which was inserted in Step 3 of the "Pre-Disassembly Procedure" should remain in place throughout this procedure.

1. Place new washer on new shoulder bolt.
2. Place the lever bar in the lock and hold it in place.
3. Insert the corners of the cover plate under both the assembly tabs in the fifth wheel casting. See **FIGURE 7**.
4. Install shoulder bolt/washer through holes in cover plate and lever bar. See **FIGURE 8**.
5. Insert bolt into threaded fifth wheel casting receptacle. Tighten shoulder bolt in fifth wheel casting receptacle until **not more than 3/16"** free play remains in the component stack: washer, cover plate and lever bar shown in **FIGURE 9**.
6. Use a torque wrench to tighten bolt to 80 ft-lbs.
7. Verify the lever bar and cover plate are free to move up and down around the shoulder bolt as shown in **FIGURE 9**.

IMPORTANT: There should **not** be more than 3/16" free play. If there is, remove and reinstall shoulder bolt ensuring that the shoulder bolt is through both the cover plate and lever bar.

Test Fifth Wheel Operation

1. Use lock adjustment tool to cycle fifth wheel open and closed three times to ensure proper operation.
 - If wheel fails to properly couple—verify as follows:
 - Free play in shoulder bolt (**FIGURE 9**).
 - Components (washer, cover plate and lever bar are in correct order in the stack (**FIGURE 9**).
 - Lever bar is correctly seated in the lock.
 - Cover plate is under both fifth wheel tabs (**FIGURE 7**).
 - Repeat Steps 1 - 7 in "Assembly of New Components."
 - If fifth wheel continues to fail to couple, refer to "Castloc & Simplex Series Jaw Removal and Replacement on Tractor" (XL-FW461).
2. Apply safe coupling decal (XL-FW523 Rev A) to a frequently observed location by the driver.

IMPORTANT: Do not use any fifth wheel that fails to operate properly.

WARNING Failure to properly couple tractor and trailer may cause separation which, if not avoided, could result in death or serious injury.

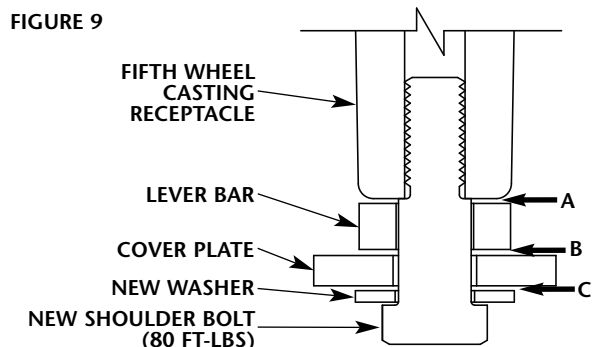
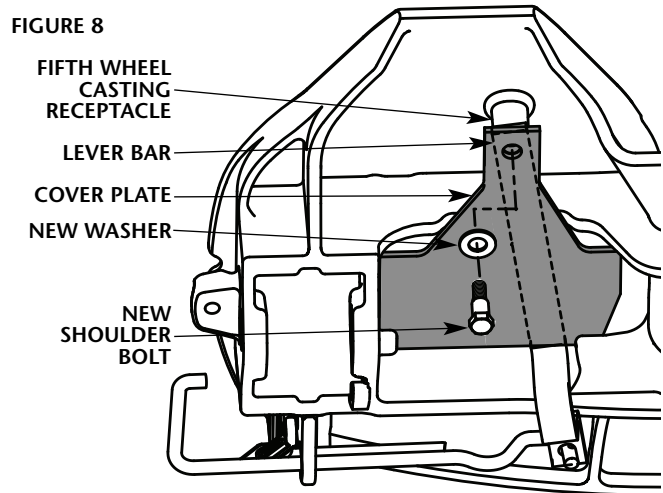
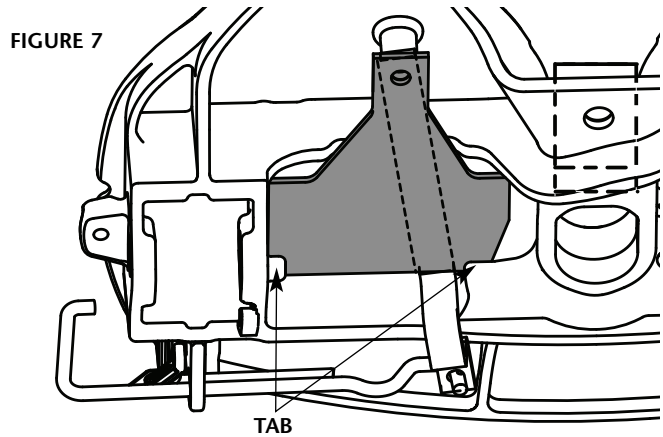

NORMAL SPACING (A, B & C) AFTER BOLT INSTALLATION. FREE PLAY IS THE ALLOWED VERTICAL MOVEMENT (3/16" TOTAL) IN WASHER/COVER PLATE/LEVER BAR STACK.



SAF-HOLLAND USA, Inc.
888.396.6501 Fax 800.356.3929

SAF-HOLLAND Canada Limited
519.537.3494 Fax 800.565.7753
Western Canada
604.574.7491 Fax 604.574.0244

SAF-HOLLAND International, Inc.
616.396.6501 Fax 616.356.1511