

Rebuild/Repair Manual

Ultralite™ and Duralite™ Suspensions

■ SPK0109 - Replacement Wear Pad Kit

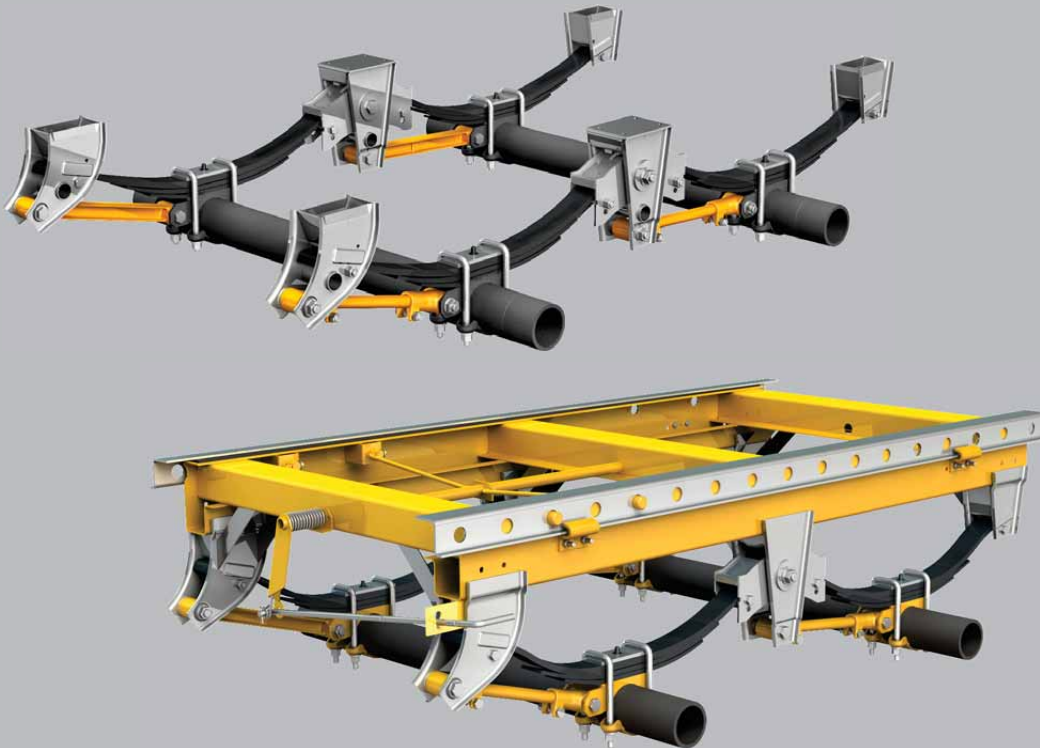

Contents	Page
Introduction	3
Warranty	3
Notes, Cautions, and Warnings	3
Section 1 – General Safety Instructions	4

Contents	Page
Section 2 – Welding Standards	5
Section 3 – Replacement Kits	6
Section 4 – Identifying Repairable Hangers	6
Section 5 – Replacement Procedures	6

Introduction

This manual provides the necessary information to properly replace the wear pad on the Ultralite™ and Duralite™ Suspensions.

Read this manual before using or servicing this product and keep it in a safe location for future reference. Updates to this manual, which are published as necessary, are available on the internet at www.safholland.us.

When replacement parts are required, SAF-HOLLAND® highly recommends the use of only SAF-HOLLAND® Original Parts. A list of technical support locations that supply SAF-HOLLAND® Original Parts and an Aftermarket Parts Catalog are available on the internet at www.safholland.us or contact Customer Service at 888-396-6501.

Warranty

Refer to the complete warranty for the country in which the product will be used. A copy of the written warranty is included with the product or available on the internet at www.safholland.com.

Notes, Cautions, and Warnings

Before starting any work on the unit, read and understand all the safety procedures presented in this manual. This manual contains the terms “NOTE”, “IMPORTANT”, “CAUTION”, and “WARNING” followed by important product information. These terms are defined as follows:

NOTE: Includes additional information to enable accurate and easy performance of procedures.

IMPORTANT: Includes additional information that if not followed could lead to hindered product performance.

CAUTION Used without the safety alert symbol, indicates a potentially hazardous situation which, if not avoided, could result in property damage.

▲ CAUTION Indicates a potentially hazardous situation which, if not avoided, could result in minor or moderate injury.

▲ WARNING Indicates a potentially hazardous situation which, if not avoided, could result in death or serious injury.

1. Safety Instructions

General and Servicing Safety Instructions

- Read and observe all Warning and Caution hazard alert messages. The alerts provide information that can help prevent serious personal injury, damage to components, or both.

⚠ WARNING Failure to follow the instructions and safety precautions in this manual could result in improper servicing or operation leading to component failure which if not avoided could result in death or serious injury.

- All maintenance should be performed by a properly trained technician using proper/special tools, and safe procedures.

NOTE: In the United States, workshop safety requirements are defined by federal and/or state Occupational Safety and Health Act (OSHA). Equivalent laws may exist in other countries. This manual is written based on the assumption that OSHA or other applicable employee safety regulations are followed by the location where work is performed.

- Properly support and secure the vehicle from unexpected movement when servicing the unit.

⚠ WARNING Failure to properly support and secure the vehicle and axles prior to commencing work could create a crush hazard which, if not avoided, could result in serious injury or death.

IMPORTANT: The trailer **MUST** be unloaded before beginning service procedures.

⚠ WARNING Failure to follow manufacturer's instructions regarding spring pressure could allow unexpected release of energy which, if not avoided, could result in serious injury or death.

Operational and Road Safety Instructions

- Before operating vehicle, ensure that the maximum permissible axle load is not exceeded and that the load is distributed equally and uniformly.

2. Welding Standards

2.1 Scope

This specification applies to all components supplied by SAF-HOLLAND®, and its products. The customer assumes full responsibility for weld integrity if weld material and procedures differ from those listed below.

2.2 Workmanship

All welding on SAF-HOLLAND® products MUST be performed by a welder qualified according to the appropriate AWS standard for the weld being made or an equivalent standard. It is the responsibility of the customer to provide good workmanship when welding on SAF-HOLLAND® products.

2.3 Material

Items to be welded that are made from low carbon or high-strength alloy steel are to be welded with AWS filler metal specification AWS A5.18, filler metal classification ER-70S-3, ER-70S-6 or equivalent unless specified on the installation drawing.

NOTE: Any substitution for filler material from the above standard MUST comply, as a minimum, with the following mechanical properties:

Tensile Strength - 72k psi (496 MPa)
Yield Strength - 60k psi (414 MPa)
Charpy V Notch - 20 ft.-lbs. (27 N•m) at 0°F (-17.7°C)
% Elongation - 22%

The recommended welding gas for gas metal arc welding (GMAW) is 90% Argon / 10% CO₂. If a different gas is used, welds MUST comply with penetration requirements illustrated (**Figure 1**). Where the installation drawing specifies different than above, the drawing shall prevail.

2.4 Procedures

Tack welds used for positioning components are to be located in the center of the final weld, where practical. Tack weld should be completely fused to the finish weld. DO NOT break arc at the end of the weld. Back up all finish welds at least 1/2" (12.7 mm) or a sufficient amount to prevent craters at the end of the weld. Where weld is shown to go around corners, it is assumed the corner represents a stress concentration area. DO NOT start or stop weld within 1" (25.4 mm) of the corner. Particular care should be taken to prevent undercutting in this area.

2.5 Weld Size

If weld size is not specified, the effective throat of the weld MUST be no smaller than the thinnest material being welded (**Figure 1**).

Figure 1

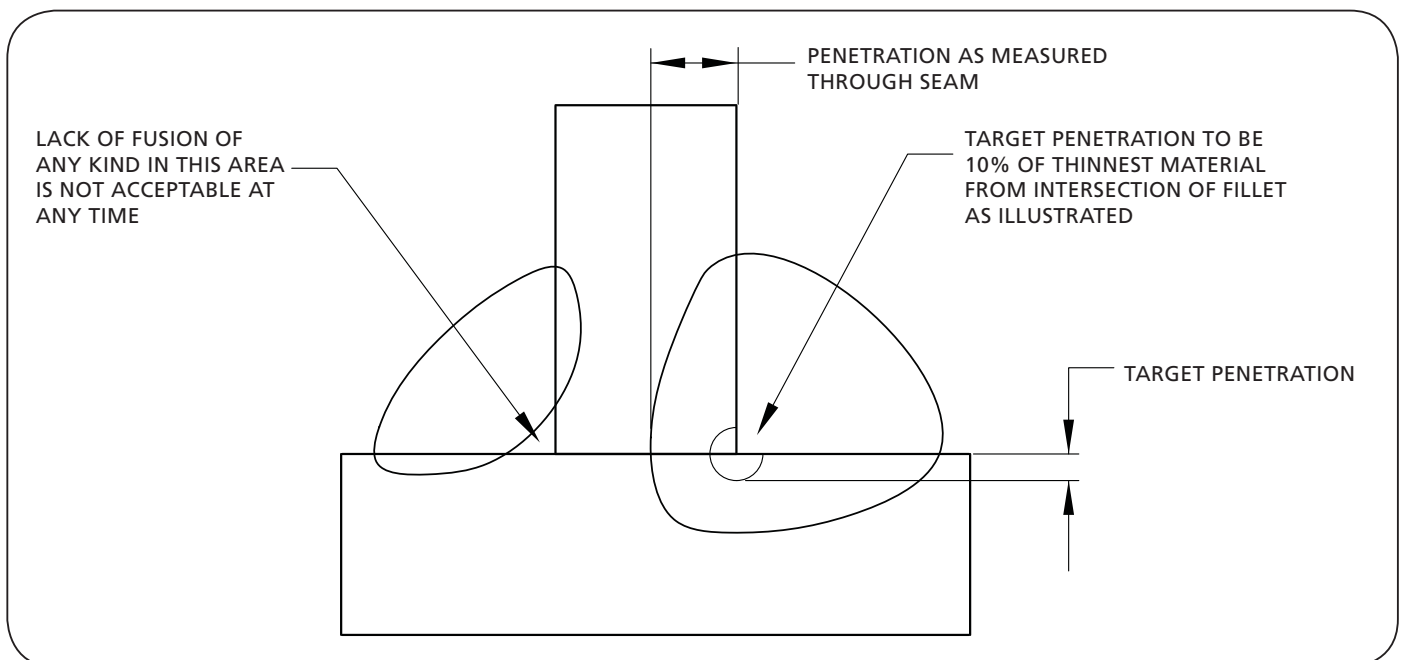

3. Replacement Kit Contents

Replacement of roadside and curbside rear or front hangers wear pad. (Not used on Under Mount Front Hangers.)

SPK0109 (FIGURE 2)			
ITEM	DESCRIPTION	PART NUMBER	QTY.
1	Pad, Field Replacement	SP0334	2

*Kit contains components for replacement of roadside and curbside rear or front hangers wear pads (not used on under mount front hangers).

4. Identifying Repairable Hangers

1. Repair hangers with wear pads if the hanger is in good condition (**Figure 3**). Hangers that have wear holes **MUST** be replaced with a new hanger (**Figure 4**).

5. Replacement Procedures

IMPORTANT: The trailer **MUST** be unloaded before beginning service procedures.

1. On a level surface, support the front of the trailer with either a kingpin stand, landing gear, or coupled to a tractor.
2. Raise the trailer frame approximately 2" (51 mm) above the suspension's specified ride height.
3. Place multiple jack stands at the suspension's specified ride height under the vehicle frame at OEM specified locations, then lower the trailer onto the jack stands.

NOTE: It may be necessary to shim jack stands to achieve specified height.

4. Set parking brakes, and chock the wheels.

⚠ WARNING Failure to properly support the suspension during maintenance could create a crush hazard which, if not avoided, could result in death or serious injury.

5. Remove the rebound bolt from hanger.
6. Raise trailer so that the spring leaf can be removed from the hanger to be repaired.

Figure 2

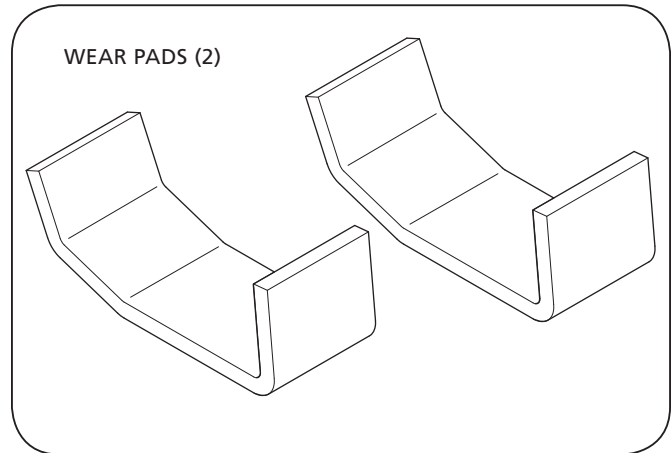

Figure 3

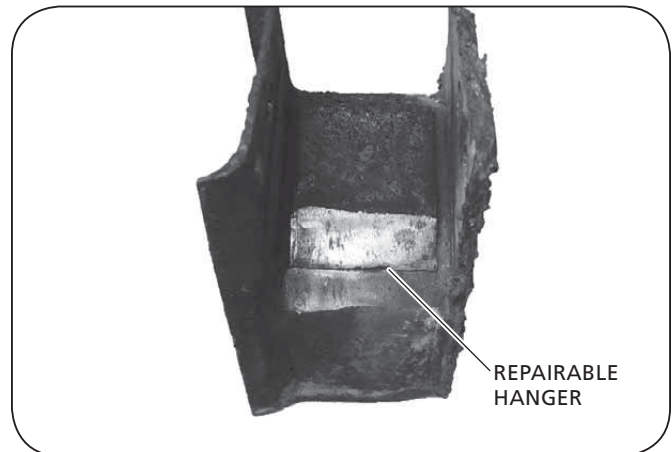
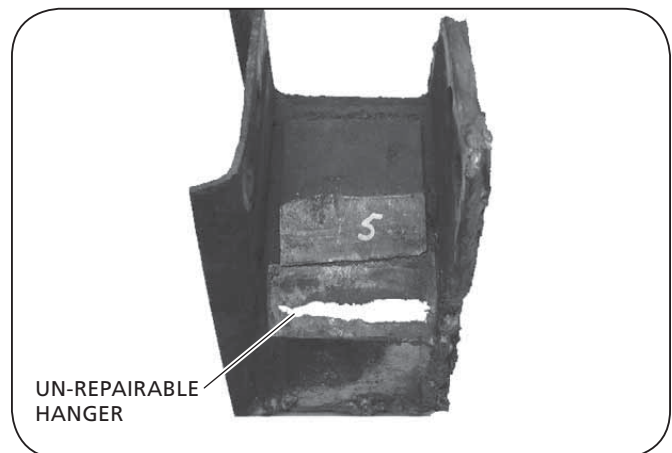

Figure 4



7. Position the new wear pad in hanger as illustrated (**Figure 5**). The new wear pad is placed on top of the existing, worn pad.
8. The long end of the wear pad is placed on the existing wear pad and the short end is placed against the back of the hanger.

NOTE: Be sure new wear pad makes contact with both the old wear pad, and worn end of the hanger.

9. Weld as illustrated in **Figure 5**.

10. Raise the trailer.
11. Remove the jackstands.
12. Lower the trailer so that the spring leaf meets the suspension hangers.
13. Replace rebound bolt and other components removed for repair. Refer to XL-MS175 for assembly and axle alignment.
14. Remove the wheel chocks.
15. Align the trailer. Refer to XL-MS175.

Figure 5

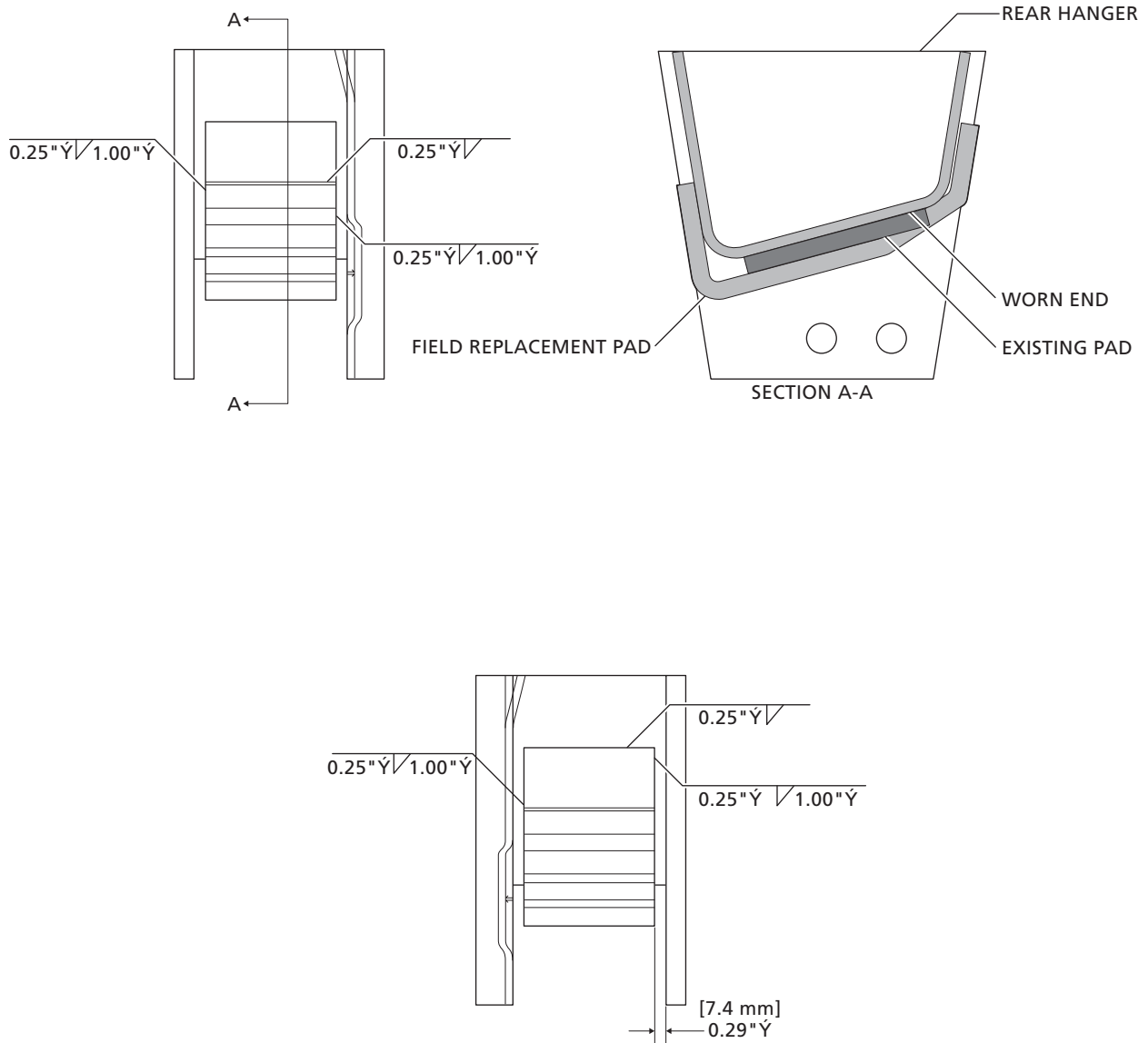



From fifth wheel rebuild kits to suspension bushing repair kits, SAF-HOLLAND Original Parts are the same quality components used in the original component assembly.

SAF-HOLLAND Original Parts are tested and designed to provide maximum performance and durability. Will-fits, look-alikes or, worse yet, counterfeit parts will only limit the performance potential and could possibly void SAF-HOLLAND's warranty. Always be sure to spec SAF-HOLLAND Original Parts when servicing your SAF-HOLLAND product.

SAF-HOLLAND USA • 888.396.6501 • Fax 800.356.3929
www.safholland.us

SAF-HOLLAND CANADA • 519.537.3494 • Fax 800.565.7753
WESTERN CANADA • 604.574.7491 • Fax 604.574.0244
www.safholland.ca

SAF-HOLLAND MEXICO • 52.55.5362.8743 • Fax 52.55.5362.8743
www.safholland.com.mx

info@safholland.com