



# COUPLER PRODUCTS

## PH-210, PH-310, & PH-410 INFORMATION



### Plunger adjustment procedures for PH-210, PH-310, and PH-410 Series Pintle Hooks Using TF-03147-10 Adjustment Gage

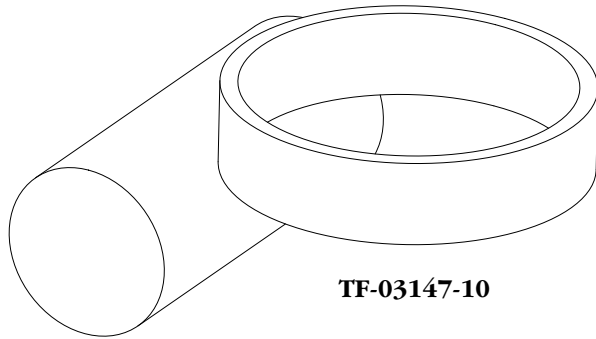

TF-03147-10

1. Place tool, TF-03147-10, over horn of pintle hook as shown in Figure 1, then close and lock latch.
2. Energize plunger air cylinder.

**WARNING** Always lock latch keeping hands and fingers away from plunger motion or serious injury could occur.

3. Adjust air cylinder so plunger just contacts adjustment tool and the tool will not move when rotated or twisted by hand (see Figure 1).

**NOTE:** Be sure the cylinder rod and plunger rod have .63" minimum thread engagement. (Factory set engagement is approximately 1.63")

4. Tighten cylinder rod lock nut securely.
5. De-energize the air cylinder.
6. Remove adjustment gage (TF-03147-10).
7. Verify that the plunger retracts far enough to allow the drawbar to be set down over the horn properly.

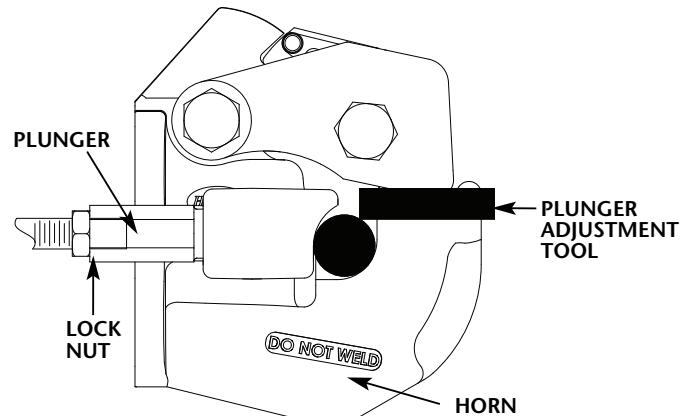

Figure 1



SAF-HOLLAND USA, Inc.  
888.396.6501 Fax 800.356.3929

SAF-HOLLAND Canada Limited  
519.537.3494 Fax 800.565.7753  
Western Canada  
604.574.7491 Fax 604.574.0244

SAF-HOLLAND International, Inc.  
616.396.6501 Fax 616.356.1511