

Installation and Operation Manual

LSZ13 Suspension



Contents	Page
Introduction.....	2
Warranty.....	2
Notes, Cautions, and Warnings.....	2
Section 1 – Safety Instructions.....	3
Section 2 – Decal Requirements.....	4
Section 3 – Model Identification.....	4
Section 4 – Recommended Rims.....	4
Section 5 – Model Nomenclature.....	5
Neway LSZ13 Series Suspension – Exploded View/Parts List.....	6
Section 6 – Welding Standards.....	12

Contents	Page
Section 7 – Pre-Installation.....	13
Section 8 – Installation.....	14
Section 9 – Alignment.....	18
Section 10 – Pre-Operation.....	19
Section 11 – Torque Specifications.....	21
Section 12 – Lubrication Specifications.....	21
Section 13 – Routine Maintenance and Inspection.....	22
Section 14 – Troubleshooting.....	25
Section 15 – Service Repair Kits.....	27

Introduction

This manual provides the necessary information for the installation, maintenance, inspection, and safe operation of the Neway® LSZ Series Auxiliary Air Suspension.

NOTE: To assist with installation, customer inspection drawing LSZ13_TAB_CI is required and is included in the literature kit.

Read this manual before using or servicing this product and keep it in a safe location for future reference. Updates to this manual, which are published as necessary, are available on the internet at www.safholland.us.

When replacement parts are required, SAF-HOLLAND® highly recommends the use of only SAF-HOLLAND Original Parts. A list of technical support locations that supply SAF-HOLLAND Original Parts and an Aftermarket Parts Catalog are available on the internet at www.safholland.us or contact Customer Service at 888-396-6501.

Warranty

Refer to the complete warranty for the country in which the product will be used. A copy of the written warranty is included with the product or available on the internet at www.safholland.com.

Notes, Cautions, and Warnings

Before starting any work on the unit, read and understand all the safety procedures presented in this manual. This manual contains the terms “NOTE”, “IMPORTANT”, “CAUTION”, and “WARNING” followed by important product information. These terms are defined as follows:

NOTE: Includes additional information to enable accurate and easy performance of procedures.

IMPORTANT: Includes additional information that if not followed could lead to hindered product performance.

CAUTION Used without the safety alert symbol, indicates a potentially hazardous situation which, if not avoided, could result in property damage.

⚠ CAUTION Indicates a potentially hazardous situation which, if not avoided, could result in minor or moderate injury.

⚠ WARNING Indicates a potentially hazardous situation which, if not avoided, could result in death or serious injury.

1. Safety Instructions

General and Servicing Safety Instructions

- Read and observe all Warning and Caution hazard alert messages. The alerts provide information that can help prevent serious personal injury, damage to components, or both.

⚠ WARNING Failure to follow the instructions and safety precautions in this manual could result in improper servicing or operation leading to component failure which, if not avoided, could result in death or serious injury.

- All installations should be performed by a properly trained technician using proper/special tools, and safe procedures.

NOTE: In the United States, workshop safety requirements are defined by federal and/or state Occupational Safety and Health Act (OSHA). Equivalent laws may exist in other countries. This manual is written based on the assumption that OSHA or other applicable employee safety regulations are followed by the location where work is performed.

- Properly support and secure the vehicle from unexpected movement when servicing the unit.

⚠ WARNING Failure to properly support and secure the vehicle and axles prior to commencing work could create a crush hazard which, if not avoided, could result in death or serious injury.

- Service both roadside and curbside of an axle. Worn parts should be replaced in sets. Key components on each axle's braking system, such as friction material, rotors and drums will normally wear over time.
- Follow all manufacturer's instructions on spring pressure and air pressure controls.

⚠ WARNING Failure to follow manufacturer's instructions regarding spring pressure or air pressure control could allow unexpected release of energy which, if not avoided, could result in death or serious injury.

- The wheel contact surfaces between the wheel and hub/drum **MUST NOT** be additionally painted.

IMPORTANT: The wheel contact surfaces **MUST** be clean, smooth and free from grease.

⚠ WARNING Failure to keep wheel and hub contact surfaces clean and clear of foreign material could allow wheel/hub separations which, if not avoided, could result in death or serious injury.

- Only the wheel and tire sizes approved by SAF-HOLLAND can be used.
- Tire clearance between tires and the suspension **MUST** be regularly monitored and maintained.

⚠ WARNING Failure to maintain tire clearance between tires and the nearest point of contact on the suspension or vehicle could cause fire or loss of vehicle control which, if not avoided, could result in death or serious injury.

Operational and Road Safety Instructions

- Before operating vehicle, ensure that the maximum permissible axle load is **NOT** exceeded and that the load is distributed equally and uniformly and in accordance with state and federal bridge laws.

- Make sure that the brakes are **NOT** overheated from continuous operation.

⚠ WARNING Failure to minimize the use of brakes during overheating conditions could result in deterioration of brake efficiency which, if not avoided, could result in death or serious injury.

- Observe the operating recommendation of the truck manufacturer for off-road operation of the installed axles.

IMPORTANT: The definition of OFF-ROAD means driving on non-asphalt/non-concrete routes, e.g. gravel roads, agricultural and forestry tracks, on construction sites and in gravel pits.

IMPORTANT: Off-road operation of axles beyond the approved application design could result in damage and impair suspension system performance.

- Follow the recommended routine maintenance and inspections described in this manual. These procedures are designed so that optimum performance and operational safety are achieved.
- The suspension springs should always be operated with a static operating pressure between 20 psi (1.38 bar) and 107 psi (7.38 bar).

⚠ WARNING Failure to operate the air springs with a proper static operating pressure could cause premature component failure and loss of vehicle control which, if not avoided, could result in death or serious injury.

- In the event of suspension air pressure loss, quickly reduce speed as safely as possible and remove the vehicle from traffic. If unable to remove vehicle from traffic, follow DOT safety requirements regarding emergency situations.
- Contact a qualified towing and/or service company to assist in repairing the vehicle or to move it to a qualified repair facility. **DO NOT** operate the vehicle in the absence of suspension air pressure; however in the event of an air system failure while in service, an internal rubber bumper built into the air spring will make it possible to temporarily operate the vehicle at reduced speed determined by road conditions.

⚠ WARNING Operating the vehicle without proper air pressure can cause tire failure, fire, or loss of vehicle control which, if not avoided, could result in death or serious injury.

- The suspension **MUST** be lifted when the vehicle is moving in reverse.

CAUTION Failure to lift axle when in reverse could result in tire or axle damage.

2. Standard Decal Requirements

The following decal **MUST** be properly installed on the truck prior to putting it in service.

- Tire Clearance Warning Decal: XL-AR356-01 (**Figure 1**).

It is the responsibility of the end user to periodically inspect all decals and ensure that they are clean and completely legible. If any decals are missing, loose, damaged or difficult to read, contact SAF-HOLLAND Customer Service at 888-396-6501 to order replacements immediately.

Figure 1

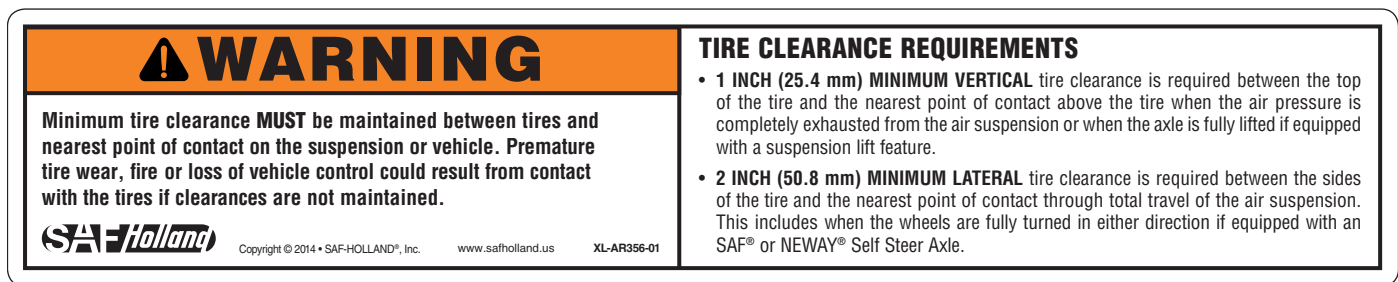
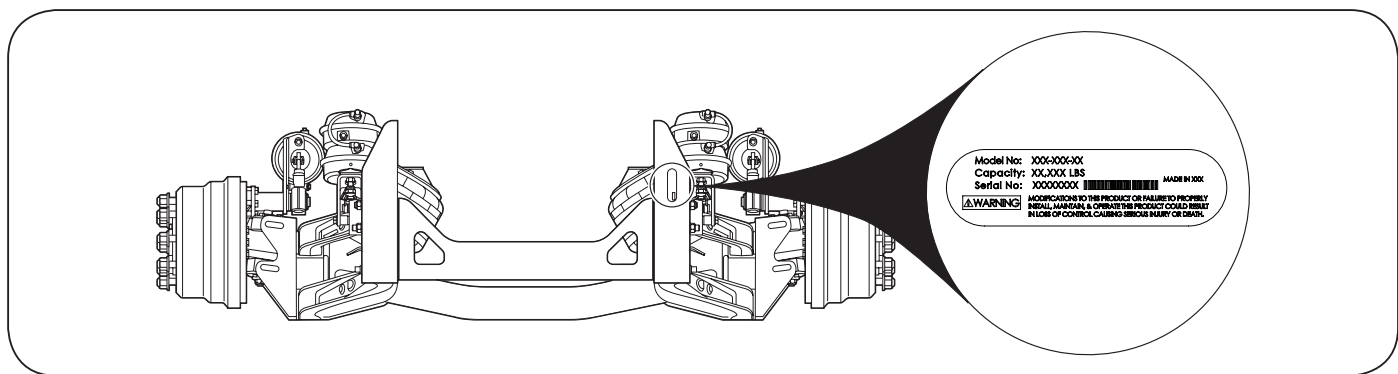

Figure 2



4. Recommended Rims

The LSZ13 hub piloted rims with diameters of 19.5", 22.5", 24.5" and a 10 hole 11.25" (285.75 mm) bolt circle.

The recommended inset should be between 4.525" and 6.025". Rim inset is measured from the rim mounting face to the centerline of the rim (**Figure 3**).

Figure 3

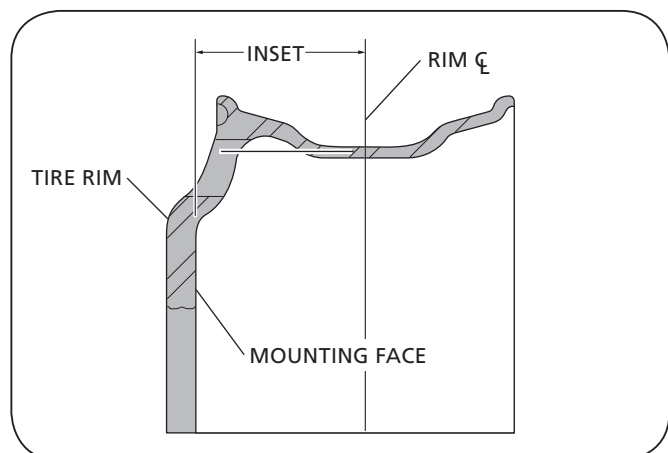

5. Model Nomenclature

IMPORTANT: This manual applies to the suspension model series listed below and for special orders of the same. It is very important to determine the specific model number, and serial number. Record those numbers below, and refer to them when obtaining information or replacement parts.

Suspension Serial/Model Data:

Serial No.: _____

Model No.: LSZ _____

In-Service Date: _____

LSZ XX XX X X X X - X X

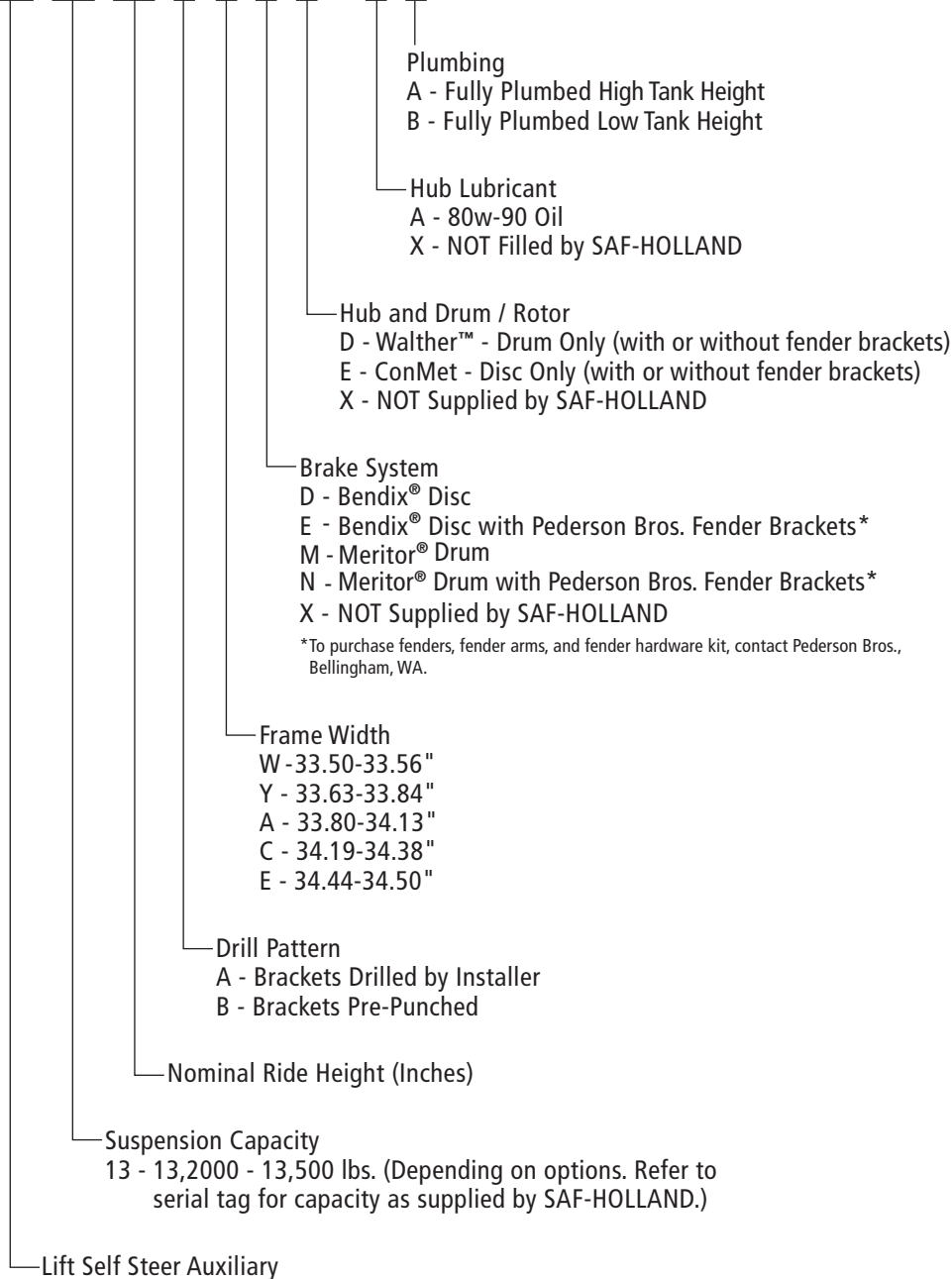

Exploded View

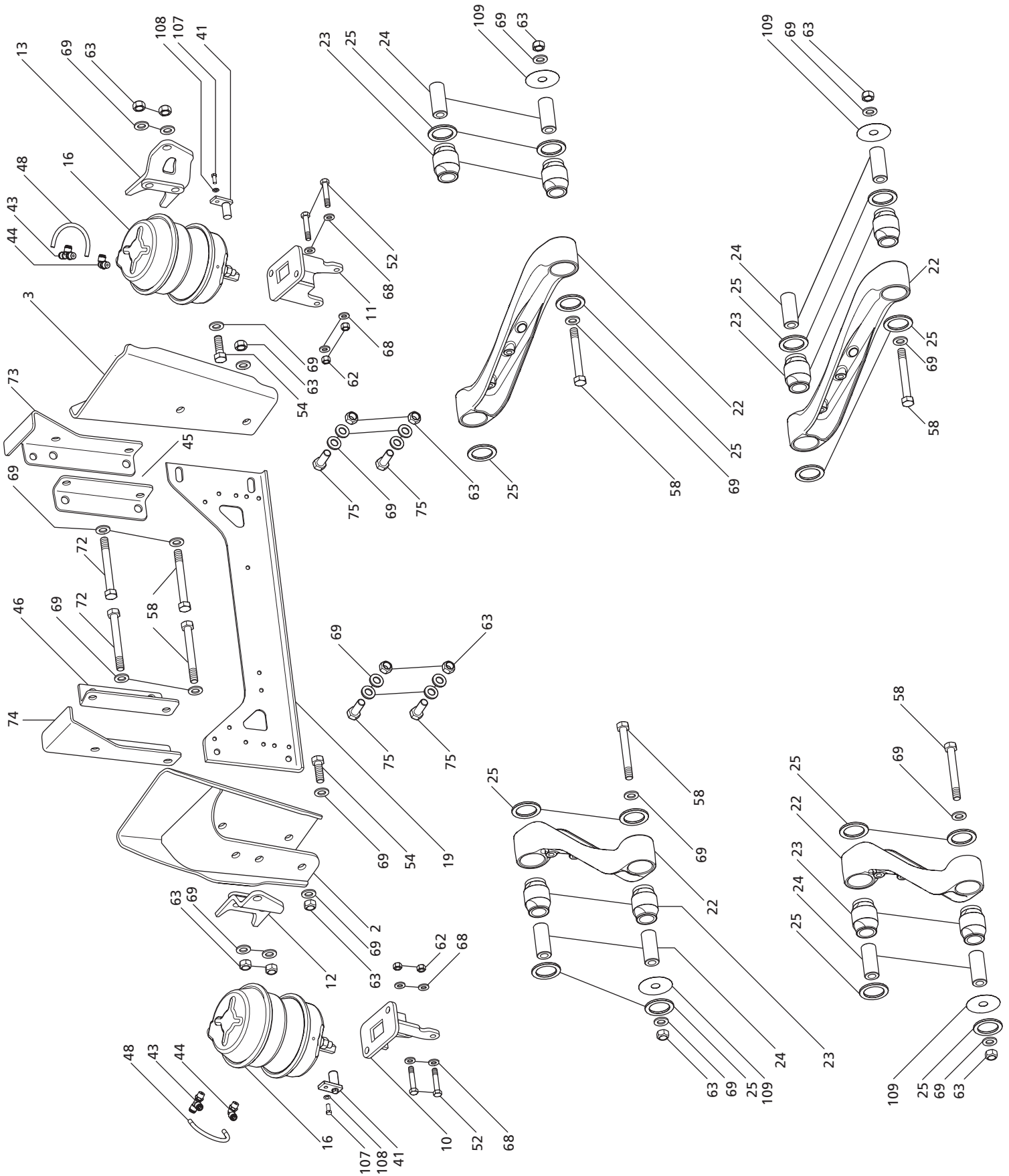

LSZ13 FRAME BRACKET AND CONTROL ARMS PARTS LIST			
ITEM	DESCRIPTION	PART NUMBER	QTY.
43	3/8" Male Run Tee	93800338	2
44	3/8" Male Elbow	93800339	2
45	Wrapper Spacer, Right-Hand	90026921	1
46	Wrapper Spacer, Left-Hand	90026920	1
48	Tube, 3/8" Diameter x 8" Long	SAF-HOLLAND Supplied	2
52	Bolt, Hex, 1/2" -13 x 2-3/4" GR 8	93002939	4
54	Cap Screw, Hex, 3/4"-10 x 2-3/4" GR 8	93003581	2
58	Cap Screw, Hex, 3/4" -10 x 6" GR 8	93003659	6
62	Nut, Hex, Lock, 1/2" -13 GR C	93400482	4
63	Nut, Hex, Lock, 3/4" -10 GR C	93400494	14
68	Washer, Flat 1/2"	93600138	8
69	Washer, Flat, Narrow, 3/4"	93600156	28
72	Cap Screw, Hex, 3/4" -10 x 7" GR 8	93003683	2
73	Shelf Bracket, Right-Handed 10" Ride Height (Shown)	90026917	1
	Shelf Bracket, Right-Handed 13" Ride Height	90026929	
74	Shelf Bracket, Left-Handed 10" Ride Height (Shown)	90026916	1
	Shelf Bracket, Left-Handed 13" Ride Height	90026928	
75	Cap Screw, Hex, 3/4" -10 x 2" GR 8	93003563	4
107	Cap Screw, Hex, 5/16" -18 x 3/4" GR 8	93002459	2
108	Washer, Lock, 0.314"	93600043	2
109	Shim, .020" Thick (Shown)	90036302	*
	Shim, .010" Thick	90036303	*
	Shim, .005" Thick	90036304	*

LSZ13 FRAME BRACKET AND CONTROL ARMS PARTS LIST			
ITEM	DESCRIPTION	PART NUMBER	QTY.
2	Frame Bracket Assembly, Left-Hand, 8 1/2" - 11 1/2" Ride Height (Shown)	90523149	
	Frame Bracket Assembly, Left-Hand, 11 1/2" - 14 1/2" Ride Height	90523153	1
	Frame Bracket Assembly, Left-Hand, Pre-Punched, 8 1/2" - 11 1/2" Ride Height	90523137	
	Frame Bracket Assembly, Left-Hand, Pre-Punched, 11 1/2" - 14 1/2" Ride Height	90523145	
3	Frame Bracket Assembly, Right-Hand, 8 1/2" - 11 1/2" Ride Height (Shown)	90523150	
	Frame Bracket Assembly, Right-Hand, 11 1/2" - 14 1/2" Ride Height	90523154	1
	Frame Bracket Assembly, Right-Hand, Pre-Punched, 8 1/2" - 11 1/2" Ride Height	90523138	
	Frame Bracket Assembly, Right-Hand, Pre-Punched, 11 1/2" -14 1/2" Ride Height	90523146	
10	Bracket Assembly, Super Chamber™, LH	90550260	1
11	Bracket Assembly, Super Chamber™, RH	90550262	1
12	Bracket, Lower Lift, Left-Hand	90550448	1
13	Bracket, Lower Lift, Right-Hand	90550449	1
16	Super Chamber™ Assembly	90550330	2
19	Crossmember	90026901	1
22	Control Arm, Machined	90015168	4
23	Bushing	90008280	8
24	Core Pin	90038544	8
25	Washer, Lock-Out	93600566	16
41	Clevis Pin Assembly, Lift Bracket	90501539	2

* As needed.

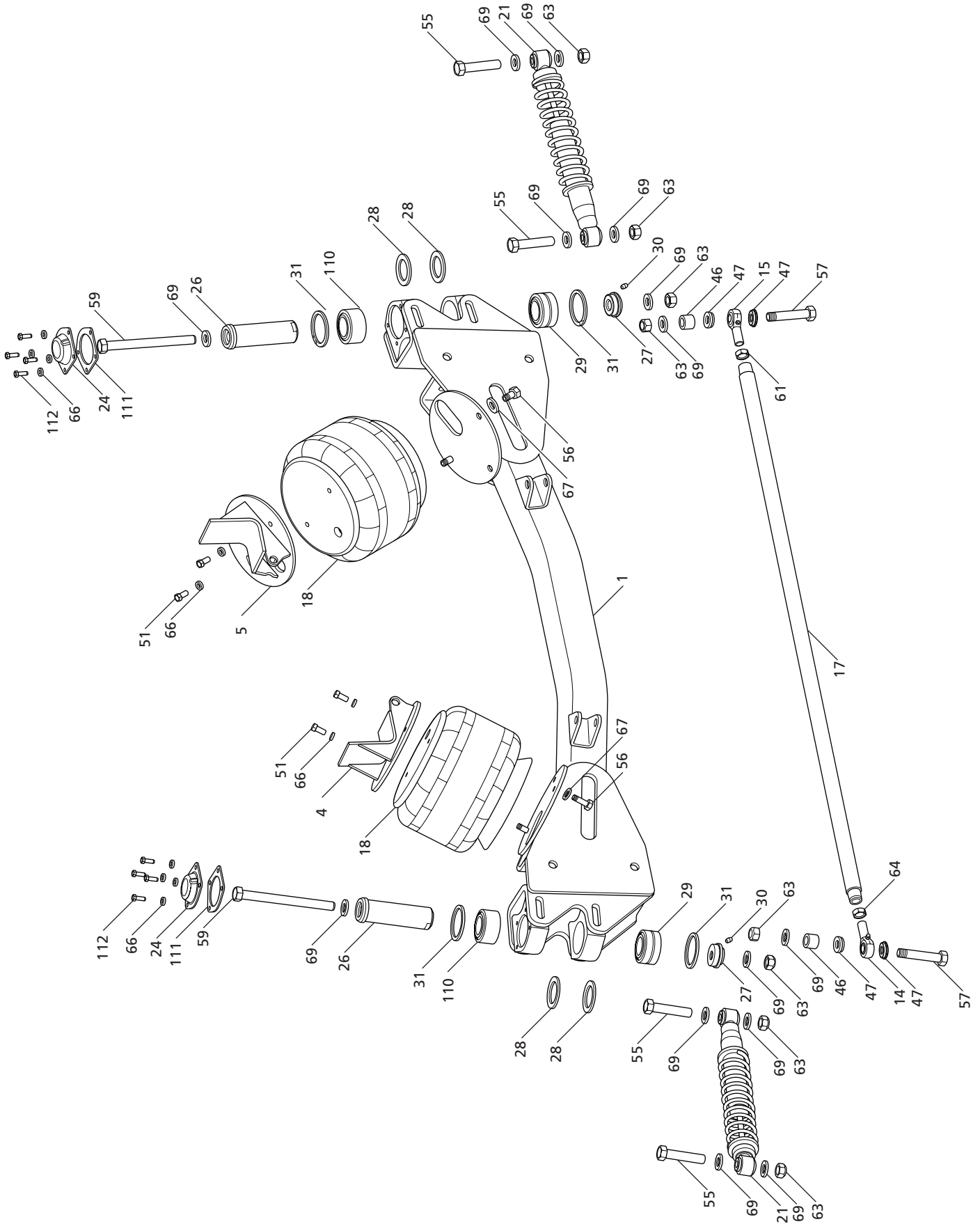

LSZ13 AXLE COMPONENT PARTS LIST			
ITEM	DESCRIPTION	PART NUMBER	QTY.
27	End Cap	90010068	2
28	Washer, Hard, Spindle	93600572	4
29	Bearing, Spherical, LOWER	90045663	2
30	Fitting, Grease	XB-767	2
31	Retaining Ring	90045755	4
46	Spacer, Rod End	90036293	2
47	Rod, Seal	90045756	4
51	Bolt, Hex, 3/8" -16 x 1" GR 8	93002573	4
55	Cap Screw, Hex, 3/4" -10 x 4" GR 5	93003609	4
56	Bolt Hex, 1/2" -13 x 1 1/2" GR 5	93002907	4
57	Cap Screw, Hex, 3/4" -10 x 4 1/4" GR 8	93003617	2
59	Cap Screw, Hex, 3/4" -10 x 9 1/2" GR 8	93003743	2
61	Jam Nut, 3/4" -16 GR C	93400271	1
63	Nut, Hex, Lock, 3/4" -10 GR C	93400494	8
64	Jam Nut, 3/4" -16, Left-Hand	93400631	1
66	Washer, Lock, 3/8"	93600045	12
67	Washer, Lock, 1/2"	93600049	4
69	Washer, Flat, Narrow, 3/4"	93600156	14
110	Bearing, Spherical, Plain, UPPER	90045752	2
111	Gasket, Kingpin Cap	90045759	2
112	Bolt, Hex 1/4" -20 x 1.25 GR 5	93002361	8

LSZ13 AXLE COMPONENT PARTS LIST			
ITEM	DESCRIPTION	PART NUMBER	QTY.
1	Axle/Knuckle Weldment	90550356	1
4	Bracket, Air Spring Mount, Left-Hand, 8 1/2" -11 1/2" Ride Height	90531474	1
	Bracket, Air Spring Mount, Left-Hand, 11 1/2" -14 1/2" Ride Height	90531478	
	Bracket, Air Spring Mount, Left-Hand, Pre-Punched 8 1/2" -11 1/2" Ride Height	90531482	
5	Bracket, Air Spring Mount, Left-Hand, Pre-Punched 11 1/2" -14 1/2" Ride Height	90531486	1
	Bracket, Air Spring Mount, Right-Hand, Pre-Punched 8 1/2" -11 1/2" Ride Height	90531475	
	Bracket, Air Spring Mount, Right-Hand, Pre-Punched 11 1/2" -14 1/2" Ride Height	90531479	
14	Bracket, Air Spring Mount, Right-Hand, 8 1/2" -11 1/2" Ride Height	90531483	1
	Bracket, Air Spring Mount, Right-Hand, 11 1/2" -14 1/2" Ride Height	90531487	
14	Rod End, 3/4" -16, Left-Hand	90045696	1
15	Rod End, 3/4" -16, Right-Hand	90045695	1
17	Tie Rod Weldment	90549910	1
18	Air Spring Assembly	90557417	2
21	Steering Damper	90045662	2
24	Kingpin Cap	90026992	2
26	King Pin	90038614	2

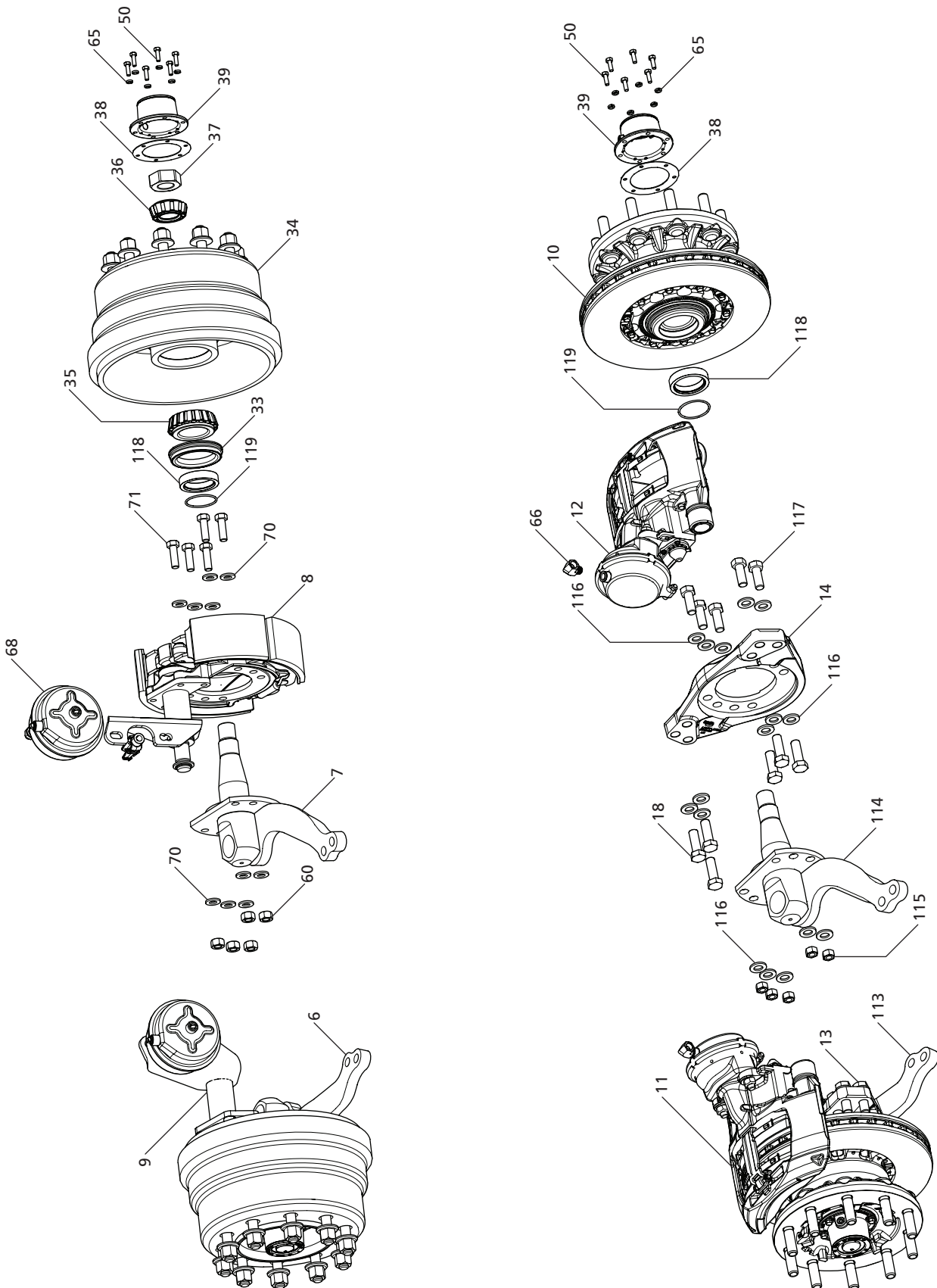

LSZ13 WHEEL END AND DISC BRAKE PARTS LIST			
ITEM	DESCRIPTION	PART NUMBER	QTY.
119	O-Ring	90070026	2
10	Hub and Rotor Assembly	90070014	2
11	Caliper, Type 14 Chamber – Left-Hand - ADB22X	90550236	1
12	Caliper, Type 14 Chamber – Right-Hand - ADB22X	90550237	1
13	Torque Plate - Left Hand	90026826	1
14	Torque Plate – Right-Hand	90026827	1
18	Bolt, M20 x 2.5 x 60 GR 10.9	20000117	12
38	Gasket	90070004	2
39	Hub Cap	90070003	2
50	Hex Head Cap Screw, 5/16" -18 x 1" GR 5	93002463	12
65	Washer, Lock, 5/16"	93600043	12
66	Fitting, Street Elbow, 3/8 x 3/8	90060049	2
113	Spindle Assembly, Left-Hand, Disc Brake	90550240	1
114	Spindle Assembly, Right-Hand, Disc Brake	90550241	1
115	Nut, Hex, Lock, 3/4" -16 GR C, Disc Brake	93400495	10
116	Washer, 3/4", Disc Brake	93600156	32
117	Bolt Hex, 3/4" - 16 x 2.25 GR 8, Disc Brake	93003570	10
118	Spacer, Seal	90026295	2
119	O-Ring	90070026	2

LSZ13 WHEEL END AND DRUM BRAKE PARTS LIST			
ITEM	DESCRIPTION	PART NUMBER	QTY.
6	Spindle Assembly, Left-Hand, Drum Brake	90549820	1
7	Spindle Assembly, Right-Hand, Drum Brake	90549838	1
8	Drum Brake Assembly, Bolt-On, Right-Hand, Meritor™	90566001	1
9	Drum Brake Assembly, Bolt-On, Left-Hand, Meritor™	90566002	1
33	Seal	90566002	2
	Hub and Drum Assembly, Webb™	90570000	
34	Hub and Drum Assembly, KIC™	90570004	2
	Hub and Drum Assembly, Walther™	90570005	
35	Taper Bearing Cone, 2-5/8" Inboard	90070001	2
36	Taper Bearing Cone, 1-3/4" Outboard	90070002	2
37	Nut, Pro-Torq®	90070005	2
38	Gasket	90070004	2
39	Hub Cap	90070003	2
50	Hex Head Cap Screw, 5/16" -18 x 1" GR 5	93002463	12
65	Washer, Lock, 5/16"	93600043	12
68	Service Chamber – Type 20	90566010	2
60	Nut, Hex, Lock, 5/8" -18 GR C, Drum Brake	93400491	10
70	Washer, Flat Hard, 5/8" - 18 x 2", Drum Brake	93600555	20
71	Bolt Hex, 5/8" - 18 x 2" GR 8, Drum Brake	95003348	10
118	Spacer, Seal	90026295	2

6. Welding Standards

6.1 Scope

The Neway suspension has been designed to be installed on a truck with no welding required. When welding is required for suspension repairs, observe the requirements below. Customers may NOT weld on an SAF-HOLLAND suspension without prior approval, including the application of the American Welding Society standards by SAF-HOLLAND engineering. This specification applies to all components supplied by SAF-HOLLAND, and its products. The customer assumes all responsibility for weld integrity if the weld material and procedure differ from those listed below.

6.2 Material

Frame attachment components made from low carbon or high strength alloy steel are to be welded with AWS filler metal specification AWS A5.18, filler metal classification ER-70S-3, ER-70S-6 or equivalent unless specified on the installation drawing.

NOTE: Any substitution for filler material from the above standard MUST comply, as a minimum, with the following mechanical properties:

Tensile Strength - 72k psi (496 MPa)
 Yield Strength - 60k psi (414 MPa)
 Charpy V notch - 20 ft-lb (27 N•m) at 0° F (-17.7° C)
 % Elongation - 22%

The recommended welding gas for gas metal arc welding (GMAW) is 90% Argon/10% CO₂. If a different gas is used, welds MUST comply with penetration requirements as illustrated below (**Figure 4**). Where the installation drawing specifies different than above, the drawing shall prevail.

6.3 Procedures

Tack welds used for positioning components are to be located in the center of the final weld, where practical. Tack weld should be completely fused to the finish weld. DO NOT break arc at the end of the weld. Back up all finish welds at least 1/2" (12 mm) or a sufficient amount to prevent craters at the end of the weld. Where weld is shown to go around corners, it is assumed the corner represents a stress concentration area. DO NOT start or stop weld within 1" (25 mm) of the corner. Particular care should be taken to prevent undercutting in this area.

6.4 Workmanship

It is the responsibility of the Customer to provide good workmanship when attaching the components to the frame structure.

6.5 Weld Size

If weld size is NOT specified, the effective throat of the weld MUST be no smaller than the thinnest material being welded (**Figure 4**).

Figure 4

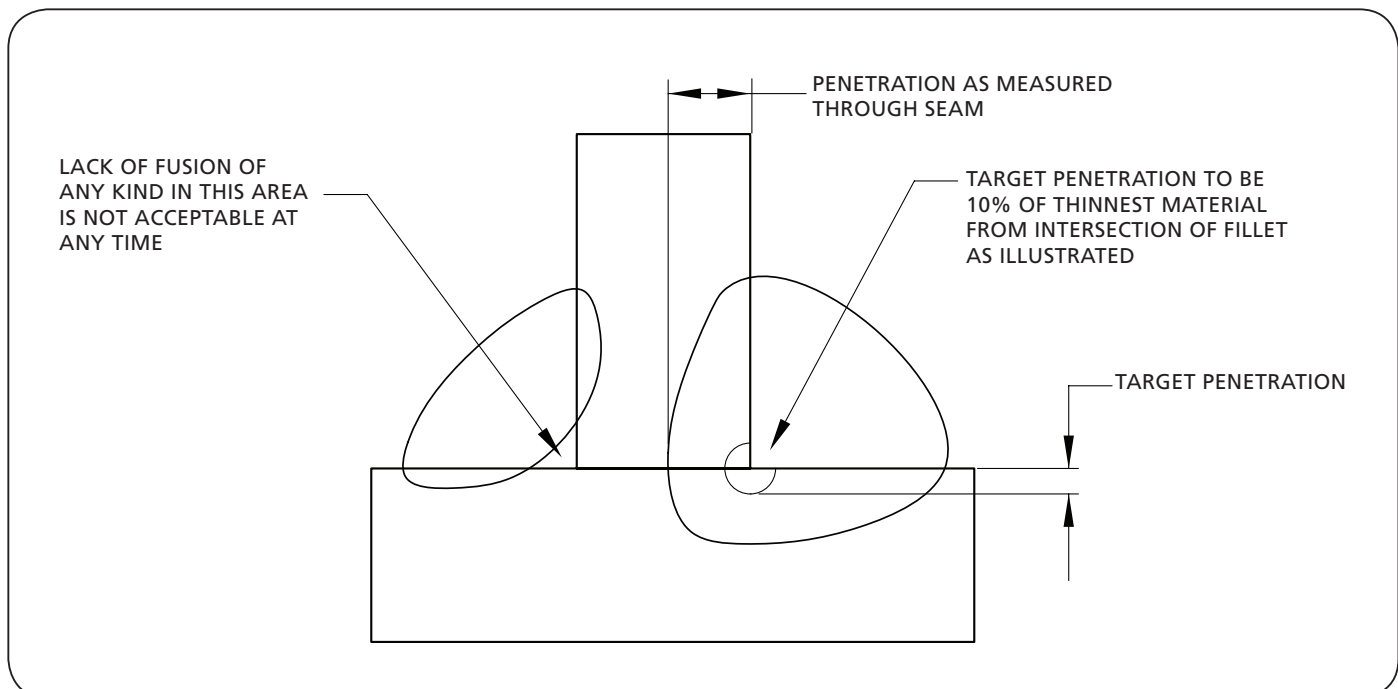

7. Pre-Installation

- With the vehicle on a level surface, set the parking brakes and chock the drive tires to prevent the vehicle from rolling forward or backward.

⚠ WARNING Failure to properly secure the vehicle prior to commencing work could create a crush hazard which, if not avoided, could result in death or serious injury.

⚠ WARNING Positioning the auxiliary axle too far forward can unload the front axle which may affect vehicle control and safe operation.

- Determine fore/aft centerline of lift axle. Ensure that this is in compliance with State and Federal Bridge Laws. Scribe a line or mark this position on frame rail (**Figure 5**).
- Calculate ride height (RH) of lift suspension by subtracting the static loaded tire radius (SLR) from the frame to ground (FG) at the lift axle center line (**Figure 6**).
- Determine the distance from the axle centerline to the front face of the frame bracket by matching the calculated ride height with the "A" dimension in **Table 1**. Scribe a line or mark this position on frame rail (**Figure 7**).

Calculate Ride Height:

A = Bottom of frame to ground at Axle center line (fully loaded).

B = Static loaded radius (SLR) of tire.

C = Ride height (A-B)

Table 1

MODEL	RIDE HEIGHT	"A" DIMENSION
LSZ1310	8.5"	17-13/16"
	9"	17-5/8"
	9.5"	17-1/2"
	10"	17-3/8"
	10.5"	17-3/16"
	11"	17"
LSZ1313	11.5"	16-3/4"
	11.5"	17-13/16"
	12"	17-5/8"
	12.5"	17-1/2"
	13"	17-3/8"
	13.5"	17-3/16"
	14"	17"
	14.5"	16-3/4"

IMPORTANT: Frame rake changes the designed caster angle of the suspension and may lead to hindered product performance, avoid frame rake angles in excess of 1° equals 1" (25 mm) frame height change in 60" (1524 mm).

- The front edge of the air spring mount bracket is 17 3/16" rearward of the front face of the frame bracket. Scribe a line or mark this position on frame rail (**Figure 7**). Repeat on opposite side.

Figure 5

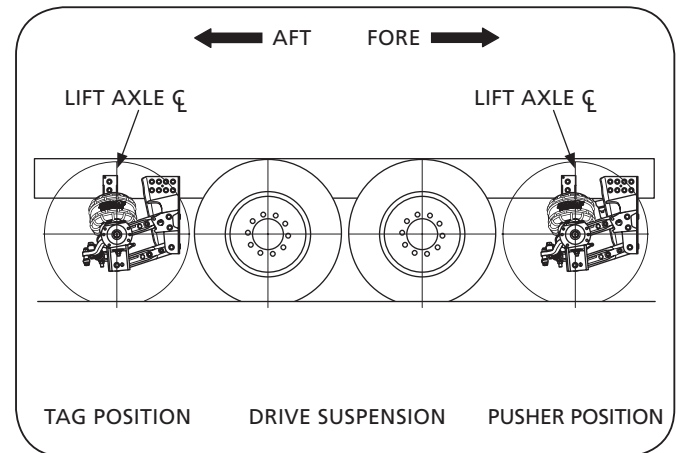

Figure 6

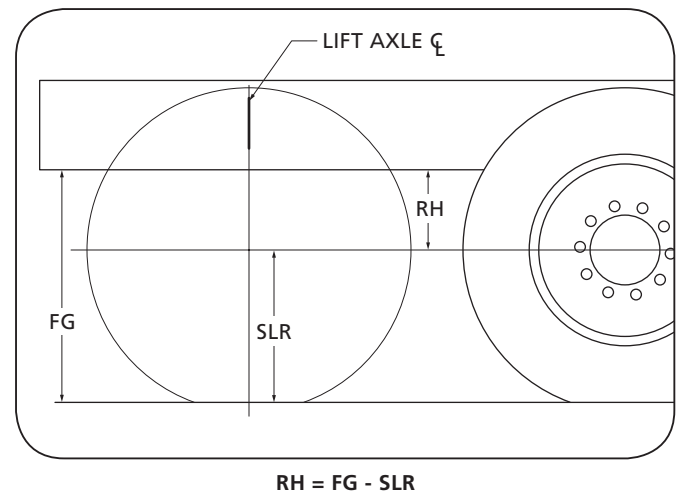
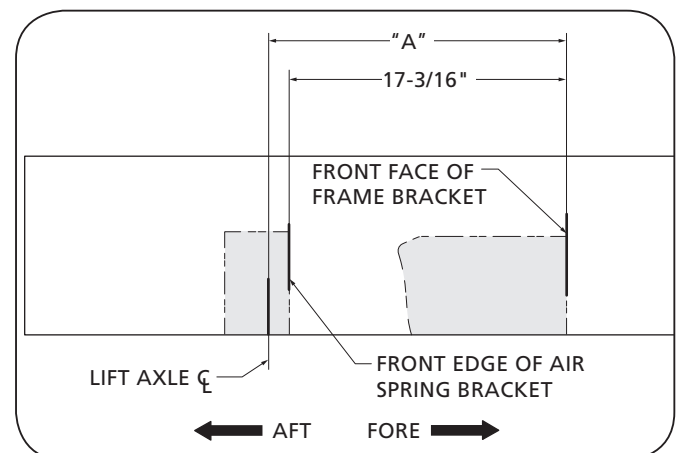

Figure 7



8. Installation

Required Tools: ■ 1-1/8" wrench ■ 1-1/8" socket
 ■ 15/16" wrench ■ 2" tall block

NOTE: To provide adequate clearance to install frame attaching hardware it is necessary to partially remove the SuperChamber.

1. Remove and retain both 5/8" - 11 nuts and lock washers for the studs and lift the SuperChamber from the bracket - Brace with 2" tall block. Repeat on opposite side (**Figure 8**).
2. Loosen the two (2) 3/4" lock nuts on the curbside of the cross member (**Figure 9**).
3. Clamp both of the frame brackets to the frame rails ensuring the front face of the brackets are aligned with the "A" dimension marked on the rails (**Figure 10**). Refer to Section 7, step 4.

IMPORTANT: Make sure the frame brackets are tight up against the bottom of the rail flange.

CAUTION

Failure to properly align the lift axle with the drive axle could lead to reduction in maximum steer angle, which if not avoided could result in excessive tire wear.

4. Verify axles are aligned.
5. Clamp both upper air spring brackets to the frame rails ensuring that the front edge of the brackets are aligned with the position marked on the rail (**Figure 10**). Refer to Section 7, Step 5.

IMPORTANT: Make sure the air spring brackets are tight up against the bottom of the rail flange.

IMPORTANT: Make sure the slot on the air spring mounting plate is located on the forward side of the bracket assembly.

Figure 8

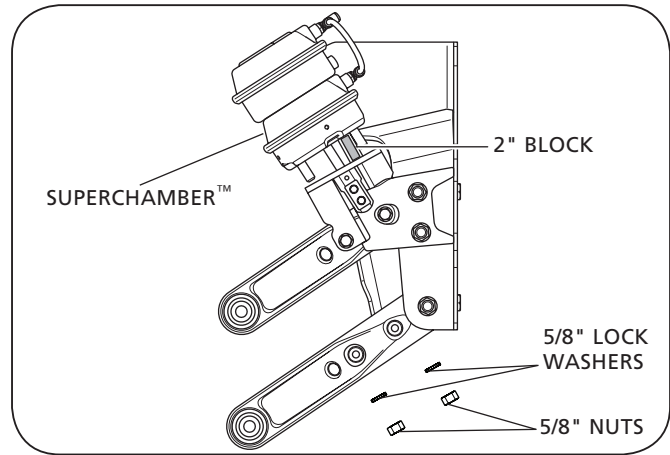

Figure 9

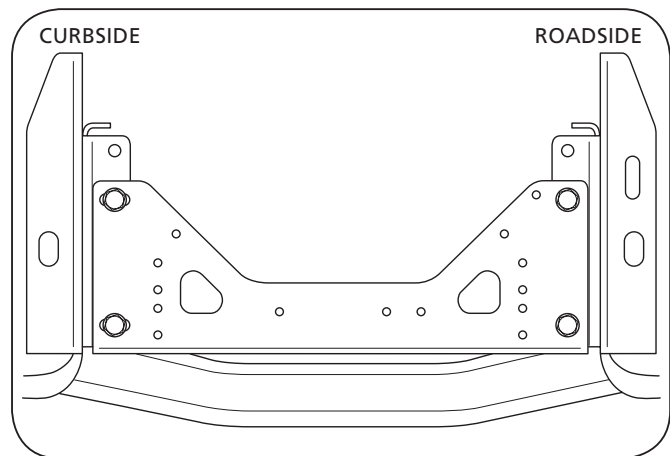
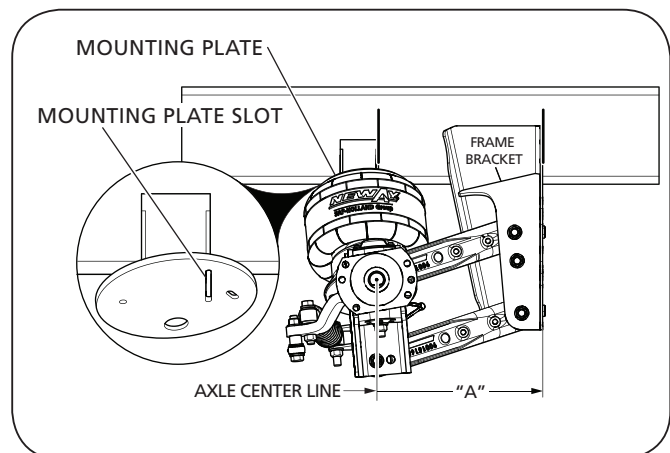

Figure 10



CAUTION

Ensure that no air lines or electrical wires are in the area to be drilled, these items could be damaged if not relocated prior to drilling.

IMPORTANT: Use a drill bit no greater than 1/16" larger than the bolt diameter when drilling frame brackets and air spring brackets.

- Drill both frame brackets, upper air spring brackets, and frame rails. Refer to LSZ13_TAB customer inspection drawing for recommended hole pattern and fastener size (**Figure 11**).

⚠ WARNING

Failure to use the required quantity and size of fasteners may cause premature failure and loss of vehicle control which, if not avoided could result in death or serious injury.

IMPORTANT: SAF-HOLLAND Recommends using Grade 8 bolts and hardened washers for all frame attaching hardware.

- Install and torque all fasteners on both sides per fastener manufacturer's specifications.
- Re-tighten the two (2) lock nuts on the curb side of the cross member (**Figure 9**) to the torque specified in **Table 3**, Section 11.
- Remove block and re-install two (2) 5/8" - 11 lock nuts to torque specified in **Table 3**, Section 11.
- Repeat Step 9 on the opposite side.

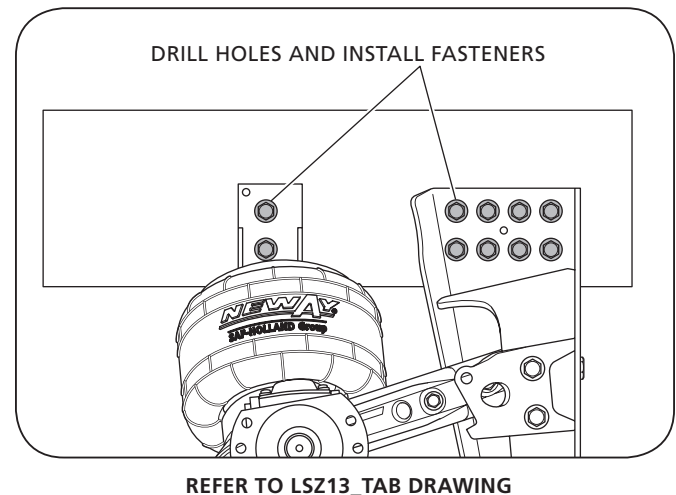
Figure 11

11. Wheel end component installation varies per manufacturer. If the wheel end components were NOT included from SAF-HOLLAND, follow the manufacturer's instructions.
12. If unit is fully plumbed, skip to Step 15.
13. Install the supply fitting into the top of the air spring.
14. Plumb the air springs and SuperChambers™ (**Figure 12**).

IMPORTANT: Install the 1/2" tubing between the control valve and the air springs to achieve the shortest lift time possible. 3/8" tubing is required between the control valve and the SuperChambers™.

IMPORTANT: The control valve air supply MUST be downstream of a DOT approved pressure protection valve.

⚠ WARNING Failure to locate the control valve air supply downstream of a DOT approved pressure protection valve could result in loss of brakes due to no or low air pressure which, if not avoided, could result in death or serious injury.

IMPORTANT: Ensure full tank pressure is applied to SuperChamber™ when axle is lifted.

15. Connect the fully plumbed axle per the following (**Figure 13**):
 - a. Connect the pilot port of the brake relay valve to the chassis brake signal using 1/4" air tube.
 - b. Connect the pilot port of the lift axle control valve to the lift axle's air pressure regulator using 1/4" air tube.
 - c. Connect the solenoid of the lift axle control module to the lift axle's electrical user controls.

NOTE: The solenoid is NOT polarity sensitive.

- d. Connect the air tank inlet of the lift axle to the truck's air system using 1/2" air tube.

Figure 12

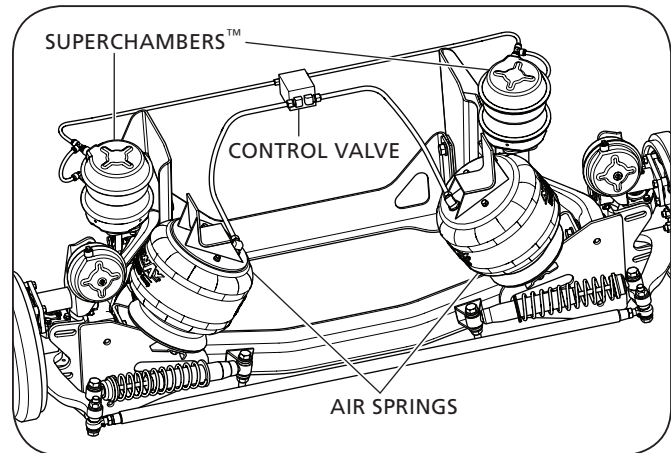
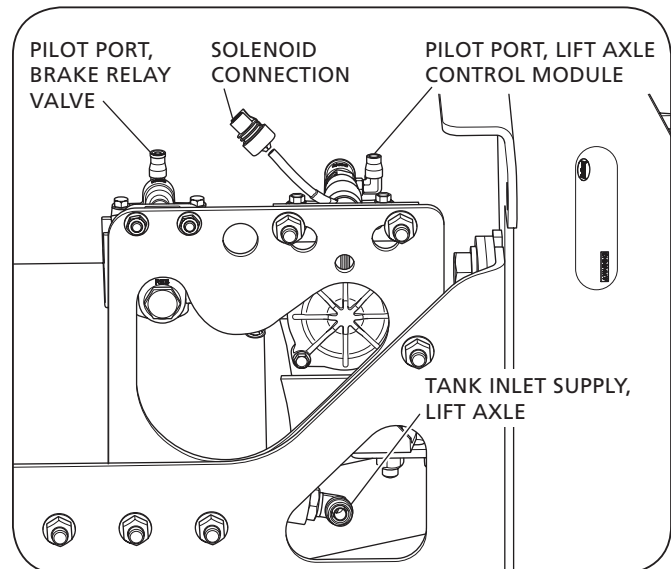

Figure 13



NOTE: The lift axle control valve is shipped in the "normally closed" configuration. For installations where "normally closed" is preferred, switch the positions of the 1/8" NPT vent plug (plastic) and 1/8" NPT x 1/4" elbow (brass) (**Figure 14**). Use care when installing the plastic vent plug.

⚠ WARNING DO NOT supply the lift axle's air tank from a pressure protected valve; doing so could result in loss of auxiliary axle brakes due to no or low air pressure which, if not avoided, could result in death or serious injury.

NOTE: Auxiliary axle user controls are sold separately. The part numbers are as follows:

- Fully plumbed axle (in-cab): 90560171
- Fully plumbed axle (exterior): 90560180
- Non-plumbed axle (in-cab): 90560162
- Non-plumbed axle (exterior): 90560163

16. If hub is NOT filled by SAF-HOLLAND, verify that proper lubrication level is in accordance with the hub manufacturer's specifications in the wheel end hub. Refer to **Table 4**.

IMPORTANT: ALWAYS make sure proper lubrication and proper levels are maintained.

⚠ WARNING Failure to operate the vehicle with lubricant levels in the hub could lead to premature bearing failure and possible separation of the wheel from axle which, if not avoided, could result in death or serious injury.

17. Attach the wheel tire assemblies with twenty (20) flange nuts, ten (10) on each side, to hand tight only. Torque the bolts as specified in the wheel manufacturer's instructions in a cross pattern (**Figure 15**).
18. With axle in the in service position, apply a minimum of 30 p.s.i. air pressure into the air springs. Check for leaks by applying a soapy water solution and checking for bubbles at the fittings and at the tube to the fitting connection.
19. Test operation by lifting the axle. Check for leaks at the SuperChamber™ by applying a soapy water solution and checking for bubbles at the fittings and at the tube to the fitting connection. Repair if needed.
20. The vehicle MUST be aligned after installation. Refer to procedures in Section 9.

Figure 14

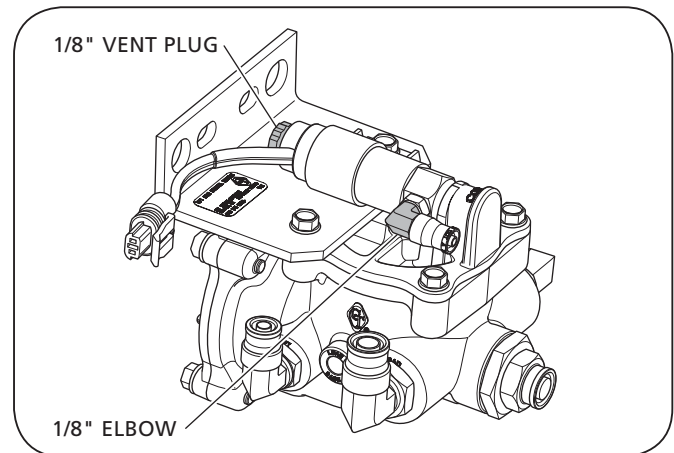
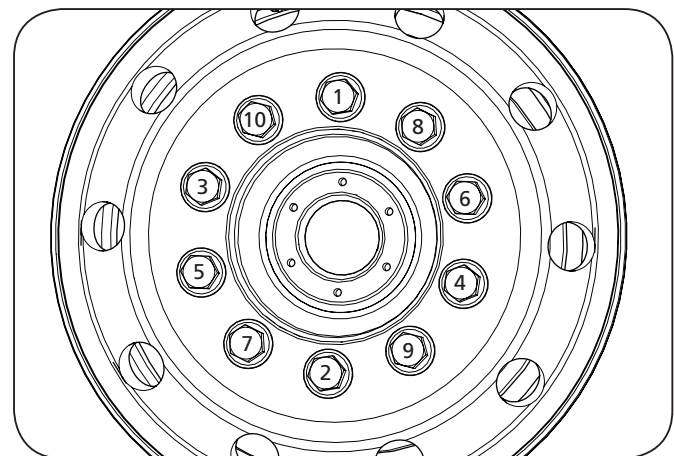

Figure 15



9. Alignment

IMPORTANT: Proper axle toe-in is essential to prevent excessive tire wear.

Required Tools:

- 1-1/8" open end wrench
- 10' tape measure (minimum length),
- Three (3) jack stands
- Standard screwdriver

1. With the vehicle on a level blade surface, set the parking brakes and chock the drive tires to prevent the vehicle from rolling forward or backward.

⚠ WARNING Failure to properly secure the vehicle prior to commencing work could create a crush hazard which, if not avoided, could result in death or serious injury.

2. Place the axle in the stowed position.
3. Position a jack stand under the axle at both ends.
4. This procedure requires two (2) people. Utilizing a jack stand, place a standard head screwdriver on top of the stand to scribe a line onto the tire tread. One person secures the position of the screwdriver while the other person slowly rotates the tire one full rotation. The resulting scribe line **MUST** overlap at both ends. If not, scribe in another position (**Figure 16**).
5. Repeat Step 4 on the opposite side.
6. Using a measuring tape, measure the cross-body distance at the front and rear of the tires from the scribe lines.
7. The rear dimension should be $1/8" \pm 1/16"$ larger than the front dimension. If not, loosen both $3/4"$ jam nuts on the tie rod assembly (**Figure 17**).

NOTE: One end of the tie rod assembly has left handed threads. This end can be identified with a groove around the tapered section close to the $3/4"$ jam nut (**Figure 17**).

8. Rotate the tie rod until the rear dimension is $1/8" \pm 1/16"$ larger than the front dimension.

⚠ CAUTION NEVER rotate the center section of the tie rod to expose more than $5/8"$ of the rod end threads. If more than $5/8"$ of the rod end thread is exposed in operation or during service the steering damper forces could cause the rod to fail prematurely which, if not avoided, could result in minor or moderate injury.

Figure 16

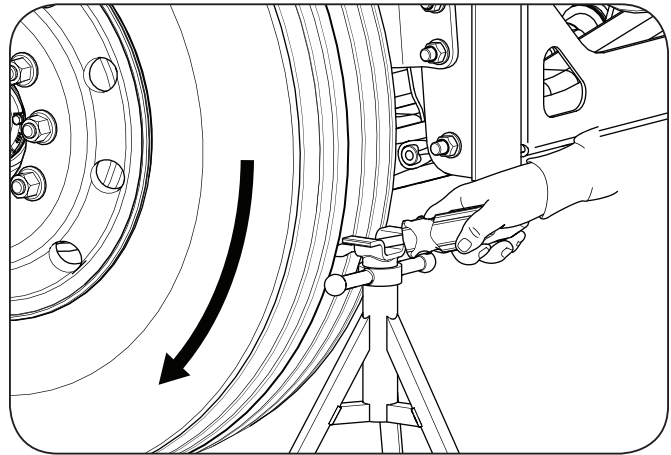
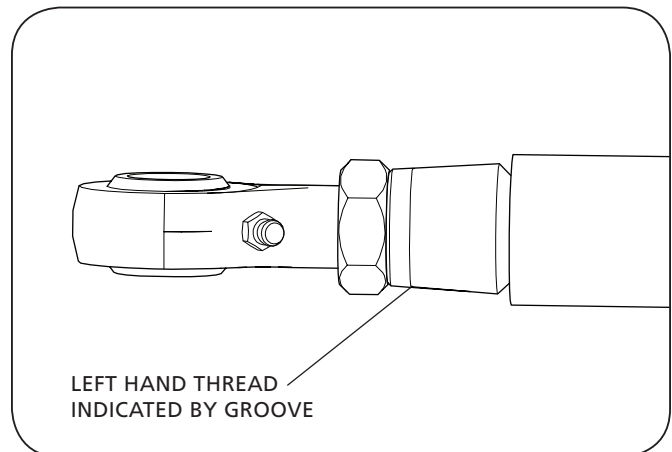

Figure 17



- Tighten both 3/4" jam nuts on the tie rod assembly.

NOTE: One end of the tie rod assembly has left handed threads. This end can be identified with a groove around the tapered section close to the 3/4" jam nut (**Figure 18**).

- Verify the front and rear dimensions. If the rear dimension is larger than the front by $1/8" \pm 1/16"$ the axle is ready for service. If the rear dimension is NOT larger by $1/8" \pm 1/16"$ repeat procedures starting with Step 7.

IMPORTANT: Proper toe-in is essential for normal tire wear (**Figure 14**).

- Build truck air pressure to 100 psi (6.89 bar) and make sure the axle is in the stowed position. Remove the jack stands.

10. Pre-Operation

A pre-service inspection MUST be completed on all vehicles prior to being placed into service. The end user bears the ultimate responsibility for completing this inspection for proper installation and operation. Inspect the following (**Figure 19**):

- Verify that the vehicle re-certification has been completed and is correct for the vehicle application.
- With the vehicle on a level surface, set the parking brakes and chock the drive tires to prevent the vehicle from rolling forward or backward.

⚠ WARNING Failure to properly secure the vehicle prior to commencing work could create a crush hazard which, if not avoided, could result in death or serious injury.

- Build the truck air pressure above 100 psi (6.89 bar).
- With the axle in service position, shut off the vehicle and visually check all the air control system fittings for air leaks by applying a soapy water solution and checking for bubbles at all air connections and fittings.
- Examine the air springs for equal firmness and leaks.
- With the axle in the stowed position, check for air leaks in the air supply tubing, control valve and all fittings by applying a soapy water solution and checking for bubbles at all air connections and fittings. Repair if needed.

Figure 18

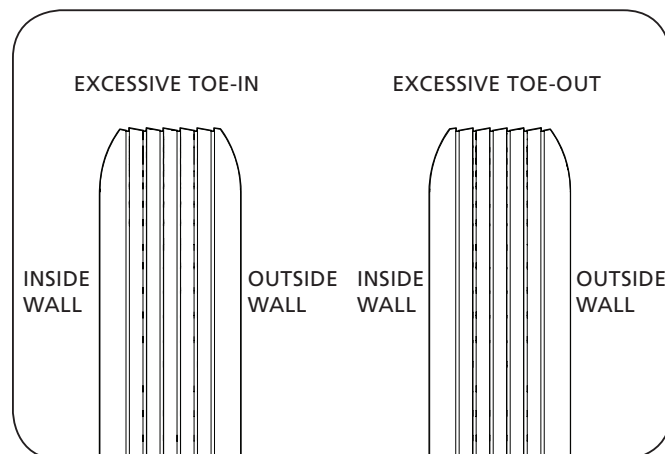

Table 2

GROUND LOAD	SUSPENSION SPRING PRESSURE*		
	RIDE HEIGHT LSZ1310/LSZ1313		
	9.0"/12.0"	10.0"/13.0"	11.0"/14.0"
7,000 lbs.	44 psi	44 psi	44 psi
8,000 lbs.	52 psi	52 psi	53 psi
9,000 lbs.	61 psi	60 psi	62 psi
10,000 lbs.	69 psi	68 psi	72 psi
11,000 lbs.	76 psi	76 psi	81 psi
12,000 lbs.	84 psi	83 psi	92 psi
13,000 lbs.	91 psi	90 psi	102 psi
13,200 lbs.	92 psi	92 psi	104 psi
13,500 lbs.	94 psi	94 psi	107 psi

*The above specifications are based on an axle equipped with Michelin® Pilot® XZA 295/80R225 on aluminum rims. If assembly is different, pressure could vary.

7. Check the clearance of the suspension and the axle assembly for interference with outside components. With the vehicle loaded at design capacity, check that there is a 1" (25 mm) minimum clearance around the air springs. If 1" (25 mm) clearance is NOT achieved, verify that the air spring mount bracket is positioned properly (**Figure 10**).
 8. Inspect for loose or missing fasteners on the entire suspension and axle assembly. Re-torque any loose fasteners.
 9. Make sure fasteners are tightened to the OEM recommended torque specification using a calibrated torque wrench in a tightening direction. The following fasteners should be inspected: Refer to Section 11.
 - Frame attachment fasteners (including Huck® bolts)
 - Suspension attachment fasteners
 - Steering damper hardware
 - Air spring and SuperChamber™ hardware
 - Tie rod to steer arm attachment hardware
 10. Check the alignment, refer to Section 9.
 11. Inspect all structural components (frame brackets, axle, control arms, etc.). Replace any cracked or damaged parts.
 12. Inspect steering damper for oil leaks. Replace as necessary.
 13. Locate and make sure all the axle grease fittings are properly lubricated. Refer to Lubrication Specifications Section 12.
- IMPORTANT:** Always grease kingpin while axle is in stowed position for proper grease distribution.
14. Inspect the adjustment of wheel end assemblies, bearing free play, and brakes according to manufacturer's specification instructions from each assembly manufacturer.

15. Verify that the proper lubrication level is in accordance with the hub manufacturer's specifications in the wheel end hub.

IMPORTANT: ALWAYS make sure proper lubrication levels are maintained.

WARNING Failure to operate the vehicle with proper lubricant levels in the hub could lead to premature bearing failure and possible separation of the wheel from the axle which, if not avoided, could result in death or serious injury.

16. Check for proper tire inflation and that the tire size meets load range specifications.

IMPORTANT: Improper tire inflation may result in poor steering and increased tire wear. Consult with tire manufacturer for proper inflation pressure per the tire's load.

17. Make sure the wheel flange nuts are torqued to the wheel manufacturer's specification.
18. Verify that the axle controls are properly located per State, Federal, and/or Provincial guidelines.
19. Identify and verify "specific" suspension adjustments per OEM guidelines:
 - Weigh the entire fully loaded vehicle with auxiliary axle(s) raised
 - Lower the auxiliary axle(s) and adjust air pressure per OEM guidelines for desired load (**Table 2**).
20. Remove the chocks from the drive tires.

Figure 19

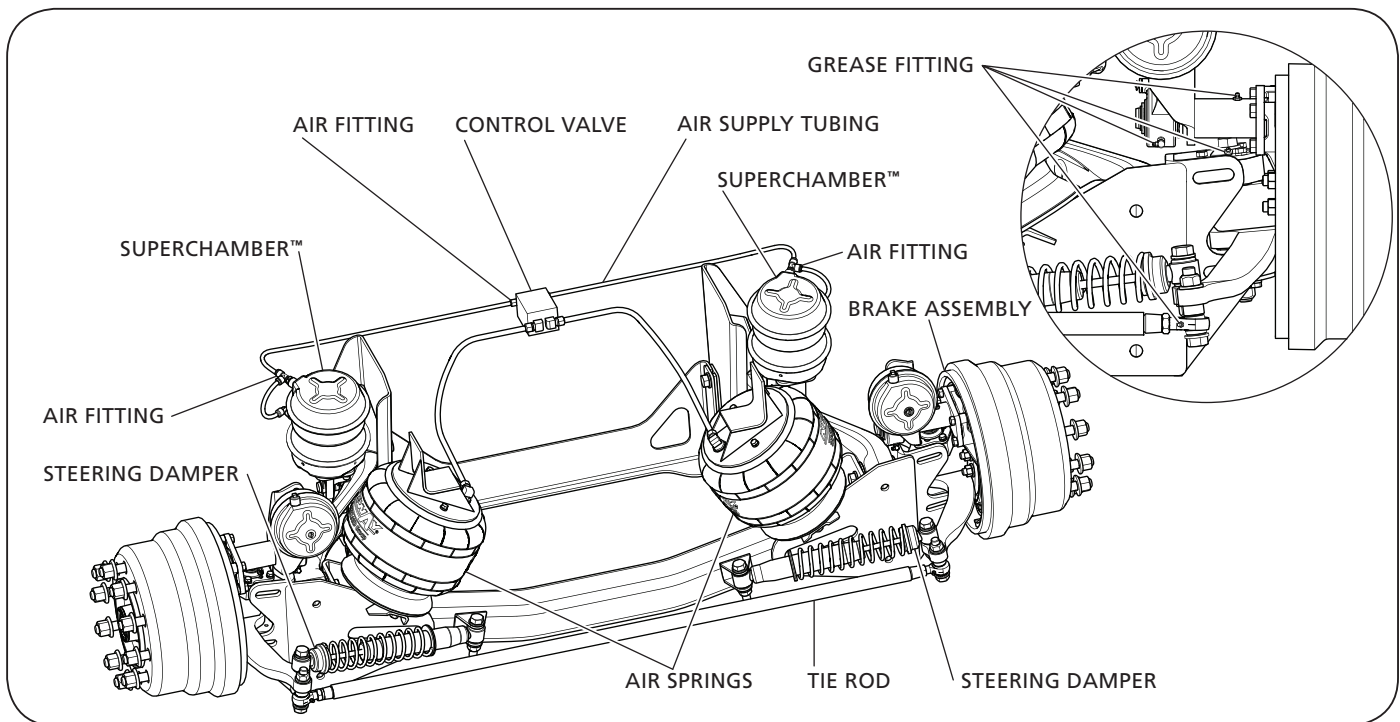

11. Torque Specifications

NOTE: Torque specifications listed (**Table 3**) are with clean lubricated/coated threads, supplied by SAF-HOLLAND.

IMPORTANT: The use of special lubricants with friction modifiers, such as Anti-Seize or Never-Seez®, without written approval from SAF-HOLLAND Engineering, will void warranty and could lead to over torquing of fasteners or other component issues.

General Information

- The torque specifications listed throughout the manual are applied to the lock nut and NOT the bolt.

IMPORTANT: Most of the fasteners used in this suspension are Grade 8 bolts and Grade C lock nuts. These fasteners have the strength and hardness properties required for their particular function. They MUST be replaced with fasteners of the same grade, size and form as the original in order to prevent failure (**Figure 20**).

⚠ WARNING Failure to use the proper fasteners when servicing the suspension could cause component failure which, if not avoided, could result in death or serious injury.

⚠ WARNING Failure to properly torque all fasteners will result in component failure which, if not avoided, could result in death or serious injury.

- All fasteners MUST be re-torqued after the first 100 hours of service or 5,000 miles (8,000 km).
- Refer to vehicle OEM for torque specifications for the vehicle frame fastener hardware.

12. Lubrication Specifications

Lubricate the suspension in accordance with the approved lubricants (**Table 4**).

IMPORTANT: Replacement of SAF-HOLLAND supplied fasteners with non-SAF-HOLLAND may result in unpredictable performance.

⚠ WARNING Failure to maintain the LSZ suspension with SAF-HOLLAND original parts can result in unpredictable performance which, if not avoided, could result in death or serious injury.

Table 3

COMPONENT	TORQUE RANGE	SIZE
Hub Cap	12-16 ft-lb 16-22 N•m	5/16"-18
Retainer	25-35 ft-lb 34-47 N•m	3/8"-16
Upper Air Spring	15-20 ft-lb 22-27 N•m	3/8"-16
Lower Air Spring	25-35 ft-lb 34-47 N•m	1/2"-13
Chamber Bracket	37-50 ft-lb 50-68 N•m	1/2"-13
Bolt-on Drum Brake Assembly	150-160 ft-lb 203-217 N•m	5/8"-11
SuperChamber™ and Service Brake Chamber	133-155 ft-lb 180-210 N•m	5/8"-11
Pivot Connections, Lift Bracket and King Pin Bolt, Tie Rod, and Crossmember	200-250 ft-lb 271-339 N•m	3/4"-10
Steering Damper	133-155 ft-lb 180-210 N•m	3/4"-10
Disc Brake Torque Plate	200-250 ft-lb 271-339 N•m	3/4"-16
Disc Brake Caliper	350-400 ft-lb 475-542 N•m	M20

Figure 20

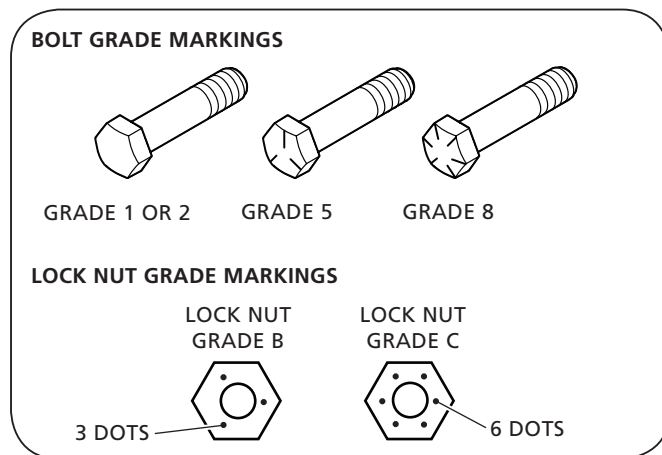

Table 4

GREASE	HUB OIL
CITGO SynDurance Premium Synthetic 460	Exxon Mobil Mobilube HD Plus 80W-90
Mystik JT-6 Hi Temp with Moly	Shell Spirax S 75W-90
Valvoline Palladium Grease	Shell Spirax ASX 75W-90
Chevron Delo Heavy Duty Moly 5% EP	Exxon Mobil Mobilube 1 SHC 75W-90
SAF Grease - 50844001	Exxon Mobil Delvac 75W-90

Table 5

HUB BRAND	OIL QUANTITY
KIC™	12 fl. Oz.
Webb®	14.5 fl. Oz.
Walther™	12.9 fl. Oz.

13. Routine Maintenance and Inspection Schedule

13.1 Daily Driver Inspections

According to Federal regulations, a daily “walk around” pre-trip inspection **MUST** be performed before a vehicle is placed into service. A daily post trip inspection **MUST** also be completed. The inspection below is an example of what should be checked per DOT requirements. Federal and State requirements may vary and the end user should identify their specific needs. Inspect vehicle for:

- Bent, cracked, or broken main structural components.
- Loose, damaged or missing fasteners (signs of movement or looseness are bright rust and polishing).
- Suspension components for visual signs of irregular movement.
- Bushings for missing, cracked, torn, or excessive gapping.
- Air springs and SuperChamber™ for damage and leaks.
- Axle assemblies for damage or signs of loose components.
- Brakes for damage, proper function, and adequate friction material.
- Wheel ends for damage, hub oil level or seal leakage.
- Tires for proper inflation, unusual or excessive tire wear, and/or damage.
- Air controls for proper operation.

13.2 Initial Service Inspection (30 Days or 200 Hours of Service)

It is recommended that the initial service inspection for auxiliary axles be completed after 30 days or 200 hours of service (whichever one comes first). Inspect the following:

1. Visually inspect the suspension for proper assembly and operation.
2. Check the clearance of suspension and axle assembly for interference with outside components.
3. Fasteners: Visually inspect for loose, damaged or missing fasteners on the entire suspension and axle assembly. Signs of movement or looseness are bright rust and polishing. Make sure all the fasteners are tightened to the specified torque. Refer to OEM torque specifications for recommended torque requirements. Use a calibrated torque wrench to check torque in a tightening direction. Re-torque if necessary. Replace any worn or damaged fasteners. The following fasteners should be inspected:
 - Frame attachment fasteners (including Huck® bolts).
 - Upper air spring mount assembly attachment fasteners.
 - Axle connection/pivot bolts – Re-torque of these fasteners is mandatory.
 - Steering damper hardware.
 - Tie rod to steer arm attachment hardware.
4. Inspect air springs for:
 - Leaks; repair as required.
 - Any signs of component contact, component damage, or signs of rubbing on the air spring or SuperChamber™; correct condition and replace as required.
5. Inspect axle assembly
 - Visually inspect for proper installation.
 - Steering knuckle and tie rod assemblies (if equipped) for proper adjustment and free rotational movement.
 - Check the steering damper coil spring.
 - Examine the steering dampers for oil leakage at the rod seal (located where the rod enters the shock body). Some oil will exit the shock body via a mist from the shock body. Misting is a normal occurrence.
 - Locate all grease fittings, and verify proper lubrication according to OEM guidelines.

IMPORTANT: For proper grease distribution, grease kingpin while axle is in the lifted position.

- Inspect brake assemblies for proper installation and operation.

6. Inspect wheel end assemblies:
 - Inspect the wheel end assemblies for seal leakage and wheel bearing free play.
 - Verify proper lubrication.

⚠ WARNING Failure to operate the vehicle with proper lubricant levels in the hub could lead to premature bearing failure and possible separation of the wheel from axle which, if not avoided, could result in death or serious injury.

- Inspect the tires for damage or excessive wear and replace if required.
 - Verify proper tire inflation.
 - Check that the wheel flange nuts are torqued in accordance with the OEM specification.
7. Inspect the air controls for proper function.
 8. Verify all grease points are properly lubricated.
 9. Inspect the lift mechanism:
 - With the axle in the stowed position, check for leaks within the SuperChamber™, all fittings and air supply tubing.
 - Check the pivot bearing within the chamber clevis for excessive wear. This can be visually checked by lifting and lowering the axle. If there is wear within the lift bearing, the chamber clevis pin will have relative motion between the pin and bushing during the lift/lowering axle movement.
 - If excessive wear in the pivot bearing is exhibited, replace the bearing.

13.3 Periodic Inspections (Every 90 Days or 600 Hours)

It is recommended that periodic maintenance inspections of auxiliary axles be completed every 90 days or 600 hours of service (whichever comes first). Inspect the following:

1. Visually inspect suspension for proper assembly and operation.
2. Check clearance of the suspension and the axle assembly for interference with outside components.

3. Fasteners: Visually inspect for loose, damaged or missing fasteners on the entire suspension and axle assembly. Signs of movement or looseness are bright rust and polishing. Make sure all the fasteners are tightened to the specified torque. Refer to OEM torque specifications for recommended torque requirements. Use a calibrated torque wrench to check torque in a tightening direction. Correct the torque if necessary. Replace any worn or damaged fasteners. The following fasteners should be inspected:
 - Frame attachment fasteners (including Huck® bolts).
 - Upper air spring mount assembly attachment fasteners.
 - Pivot connections.
 - Steering damper hardware.
 - Kingpin bolts.
4. Inspect air springs for:
 - Leaks; repair as required.
 - Any signs of component contact, component damage, or signs of rubbing on the air spring or SuperChamber™; correct condition and replace as required.
5. Inspect axle assembly:
 - Visually inspect for proper installation.
 - Steering knuckle and tie rod assemblies for proper adjustment and free rotational movement.
 - Inspect steering dampers for leakage and proper function.
 - Locate all grease fittings, and verify proper lubrication according to OEM guidelines.
 - Inspect brake assemblies for proper installation and operation.
6. Inspect wheel end assemblies:
 - Inspect the wheel end assemblies for seal leakage and wheel bearing free play.
 - Verify proper lubrication.

⚠ WARNING Failure to operate the vehicle with proper lubricant levels in the hub could lead to premature bearing failure and possible separation of the wheel from axle which, if not avoided, could result in death or serious injury.

- Inspect tires for damage or excessive wear and replace, if required.
- Verify proper tire inflation.
- Check that the wheel flange nuts are torqued in accordance with the OEM specification.

7. Inspect air controls for proper function.
8. Verify all grease points are properly lubricated.

13.4 Annual Inspection (As Part of Federal DOT Inspection)

1. Visually inspect suspension for proper assembly and operation.
2. Check clearance of the suspension and the axle assembly for interference with outside components.
3. Fasteners: Visually inspect for loose, damaged or missing fasteners on the entire suspension and axle assembly. Signs of movement or looseness are bright rust and polishing. Make sure all the fasteners are tightened to the specified torque. Refer to OEM torque specifications for recommended torque requirements. Use a calibrated torque wrench to check torque in a tightening direction. Correct the torque if necessary. Replace any worn or damaged fasteners. The following fasteners should be inspected:
 - Frame attachment fasteners (including Huck® bolts).
 - Suspension attachment fasteners.
 - Pivot connections.

NOTE: Re-torque of these fasteners is recommended as part of the annual inspection.

- Kingpin bolts.
 - Steering damper hardware.
 - Air spring/lift mechanism hardware.
4. Inspect air springs for:
 - Leaks in flex member or bead plate (top of air spring), replace air spring if leaks are detected.
 - Any sign of rubbing on the flex member.
 - Inspect SuperChambers™ for leaks, replace SuperChamber™ as required.
 - SuperChamber™ contact with frame brackets, replace SuperChamber™ and SuperChamber™ bracket, as required.
 5. Identify and verify "specific" suspension adjustments per OEM guidelines.
 6. Inspect axle assembly:
 - Visually inspect for proper installation.
 - Steering knuckle and tie rod assemblies for proper adjustment and free rotational movement.
 - Inspect steering dampers for leakage and proper function.
 - Locate all grease fittings, and verify proper lubrication according to OEM guidelines, refer to **(Figure 18)**.
 - Inspect brake assemblies for proper installation, operation, and adequate friction material.

7. Inspect wheel end assemblies:
 - Inspect the wheel end assemblies for seal leakage and wheel bearing free play.
 - Verify proper lubrication level in hub.



Failure to operate the vehicle with proper lubricant levels in the hub could lead to premature bearing failure and possible separation of the wheel from axle which, if not avoided, could result in death or serious injury.

- Inspect tires for damage or excessive wear and replace, if required.
 - Verify proper tire inflation.
 - Check that wheel flange nuts are torqued in accordance with the OEM specification.
8. Inspect the axle air controls to verify controls are operating correctly.
 9. Re-verify "specific" suspension adjustments according to OEM guidelines:
 - Weigh the entire fully loaded vehicle with auxiliary axle(s) raised.
 - Lower auxiliary axle(s) and adjust air pressure in accordance with OEM guidelines for desired load to be carried.
 - Re-weigh entire fully loaded vehicle with auxiliary axle(s) on the ground to verify proper load distribution on all axles per State/Federal/Provincial requirements.

14. Troubleshooting

PROBLEM	POSSIBLE CAUSE	SOLUTION
All air springs are flat	Insufficient air pressure in the vehicle air system	Check the air pressure gauge on instrument panel. If air pressure is low, run the engine until a minimum pressure of 70 psig (4.83 bars) is indicated on the gauge. If air pressure is 70 psig (4.83 bars) or above and the air springs are NOT inflated, the problem may be with the pressure protection valve or faulty air pressure regulator.
	Air leakage from the suspension air system or the air brake system	Visually check all air control system fittings by applying a soapy water solution and checking for bubbles at all air connections and fittings. Check for loose or damaged fittings, air lines, air springs, brake actuators or control valve. Tighten loose fittings to stop leakage and replace worn or damaged parts as necessary.
Air spring(s) deflate rapidly when vehicle is parked	Air leakage from the suspension air system	Test for air leakage due to loose fittings between air tank and air suspension or damaged air lines, air springs or height control valve. Visually check all air control system fittings by applying a soapy water solution and checking for bubbles at all air connections and fittings. Tighten loose fittings to stop leakage and replace worn or damaged parts as necessary.
Air spring(s) ruptured	Tires, rims, chains or other objects are rubbing against the air spring	Check for proper clearance between the air spring and the tire. If the tire, rim, chains or other objects contact the inflated air spring when the vehicle is loaded, a narrower set of tires and rims are necessary to provide clearance for tires with chains (contact the vehicle manufacturer for recommendations).
Air spring(s) fail	Continual or repeated over-extension of the air spring(s)	Visually inspect for broken or loose SuperChamber™ brackets or lower lift brackets. Re-connect loose parts and replace any worn or damaged parts as necessary. Check the adjustment of the pressure regulator. Refer to the manufacturer's instructions for adjustment.
	Air spring(s) worn out	Replace the air spring(s). NOTE: If the air spring piston contacts the upper bead plate, it may fracture and leak air.
Air spring(s) fail to fully deflate when all air pressure is removed from the suspension	Restricted air line(s) between the air pressure regulating valve and the air spring(s)	Check control and regulating valve.
Excessive tire wear	Axle toe-in NOT set to specifications	Re-align axle. Refer to alignment, Section 8, and tire wear illustration (Figure 18).
	Axle chamber NOT at specifications	Check the axle camber.
	Brakes dragging	Check the brake adjustment.
	Improper tire pressure	Consult with tire manufacturer to ensure proper tire pressure for the tire load.

PROBLEM	POSSIBLE CAUSE	SOLUTION
Pivot connection worn or loose	Worn bushings or loss of pivot bolt torque	<p>Check pivot connection for worn bushings or looseness by inserting a 2' pry bar between the frame bracket and the nose of the control arm assembly. Visually check for movement while moving the pry bar back and forth. Exercise care NOT to gouge or damage the components while prying back and forth. If .25" or more movement is detected, disassemble the pivot connection and visually inspect the rubber bushing.</p> <p>Check pivot connection bolt to specifications in Section 10. If it DOES NOT fall within specification, perform bushing replacement procedure per Section 10. Replace the pivot connection bushing if wear is detected.</p> <p>If the bushing appears to be in proper working condition, re-assemble the pivot connection and torque the pivot connection to the specification listed in Section 10.</p>
	Worn out due to length of service	Replace pivot connection.
Vehicle unstable or handles poorly	Loose frame bolts or attachments	Tighten frame bolts and attaching parts to proper specifications.
	Incorrect Bushings	Replace as necessary.
	Loose or worn pivot connection	<p>Check pivot connection for worn bushings or looseness by inserting a 2' pry bar between the frame bracket and the nose of the lower control arm assembly. Visually check for movement while moving the pry bar back and forth. Exercise care NOT to gouge or damage the components while prying back and forth. If .25" (6 mm) or more movement is detected, disassemble the pivot connection and visually inspect the rubber bushing.</p> <p>Replace the pivot connection bushing if wear is detected.</p> <p>If the bushing appears to be in proper working condition, reassemble the pivot connection and, with the suspension set at the proper ride height, torque the pivot connection to the specification listed in Section 10.</p>
Wheel wobble or shimmy	Loose steering dampers	Tighten damper bolts to proper specification.
	Worn steering dampers	Replace the steering dampers.
	Check axle caster angle	Check if front surface of frame brackets are perpendicular to frame rails. If NOT, loosen frame bracket attachment hardware and adjust frame bracket. Check control arm bushings for excessive wear.
Vertical play in kingpin connection	Loose kingpin bolt	Tighten kingpin bolts to proper specifications.
	Worn bearings	Rebuild kingpin connection – Refer to kingpin replacement kit.
Oil on steering damper rod	Misting	Some oil will exit the damper body via a mist. Misting is a normal occurrence.
	Leaking	Replace the damper.
Poor Steering	Dry kingpin bearing	Grease kingpin. If not resolved, a kingpin rebuild may be necessary.
	Axle toe-in not set to specs	Re-align axle. Refer to alignment Section 8, and tire wear illustration (Figure 18).
	Improper tire pressure	Consult with tire manufacturer to ensure proper tire pressure for the tire load.

If problems still persist, contact vehicle OEM or SAF-HOLLAND Customer Service at 888-396-6501.

15. Service Repair Kits

DESCRIPTION	PART NUMBER
Control Arm and Bushing Manual	XK-PS20053RM-en-US
Control Arm Kit, Lower	48100557
Control Arm Kit, Upper	48100608
Bushing Kit, Lower	48100553
Bushing Kit, Upper	48100607
Kingpin and Spindle Manual	XL-PS20068RM-en-US
Replacement Kit, Kingpin, Drum Brake	48100661
Replacement Kit, Kingpin, Disc Brake	48100683
Spindle Kit, Gen 4, Disc Brake Right-Hand	48100669
Spindle Kit, Gen 4, Disc Brake Left-Hand	48100670
Spindle Kit, Gen 4, Right-Hand	48100671
Spindle Kit, Gen 4, Left-Hand	48100672
Kingpin and Spindle Gen 3 (Legacy)	XL-PS20054RM-en-US
Replacement Kit, Kingpin, Drum Brake	48100641
Replacement Kit, Kingpin, Disc Brake	48100703
Spindle Kit, LH	48100550
Spindle Kit, RH	48100551
Spindle Kit, Disc Brake, LH	48100645
Spindle Kit, Disc Brake, RH	48100646
Tie Rod and Damper Manual	XL-PS20055RM-en-US
Tie Rod Kit	48100555
Tie Rod End Kit	48100556
Crossmember and Frame Bracket Manual	XL-PS20058RM-en-US
Frame Bracket Kit, Left-Hand, 9"-11"	48100571
Frame Bracket Kit, Right-Hand, 9"-11"	48100572
Frame Bracket Kit, Left-Hand, 12"-14"	48100573
Frame Bracket Kit, Right-Hand, 12"-14"	48100574
Shelf Bracket and Wrapper Kit, 10", Left-Hand	48100636
Shelf Bracket and Wrapper Kit, 10", Right-Hand	48100637
Shelf Bracket and Wrapper Kit, 13", Left-Hand	48100638
Shelf Bracket and Wrapper Kit, 13", Right-Hand	48100639
Crossmember Kit, (Legacy)	48100569
Crossmember Kit	48100625

DESCRIPTION	PART NUMBER
Lift Repair Manual	XL-PS20059RM-en-US
SuperChamber Kit	48100570
Hardware Kit, Mechanism	48100609
Wheel End and Brake Manual	XL-PS20062RM-en-US
Hardware Kit, Mechanism	48100609
Brake Shoe and Hardware Kit	48100559
Slack Adjuster Clevis Pin Kit	48100560
S-Camshaft Bushing Seal Kit	48100561
Brake Hardware Kit	48100562
Hub Repair Kit, Drum	48100566
Hub Repair Kit, Disc	48100706
Hub Cap Kit	48100565
Wheel Stud Kit - Walther	48100567
Wheel Stud Kit - ConMet	48100710
Kingpin and Spindle Gen 4 (Legacy) Manual	XL-PS20054RM-en-US
Replacement Kit, Kingpin	48100641
Spindle Kit, Left-Hand	48100550
Spindle Kit, Right-Hand	48100551
Spindle Kit, Disc Brake, Left-Hand	48100645
Spindle Kit, Disc Brake, Right-Hand	48100646
Bearing/Bushing Tool	48100558
Repair Kit, Fender Bracket, LH Drum Brake	48100712
Repair Kit, Fender Bracket, RH Drum Brake	48100713
Repair Kit, Fender Bracket, LH Disc Brake	48100714
Repair Kit, Fender Bracket, RH Disc Brake	48100715

NOTE: For further information refer to parts catalog XL-PS20018PM-en-US.



From fifth wheel rebuild kits to suspension bushing repair kits, SAF-HOLLAND Original Parts are the same quality components used in the original component assembly.

SAF-HOLLAND Original Parts are tested and designed to provide maximum performance and durability. Will-fits, look-alikes or, worse yet, counterfeit parts will only limit the performance potential and could possibly void SAF-HOLLAND's warranty. Always be sure to spec SAF-HOLLAND Original Parts when servicing your SAF-HOLLAND product.

SAF-HOLLAND USA • 888.396.6501 • Fax 800.356.3929
www.safholland.us

SAF-HOLLAND CANADA • 519.537.3494 • Fax 800.565.7753
WESTERN CANADA • 604.574.7491 • Fax 604.574.0244
www.safholland.ca

SAF-HOLLAND MEXICO • 55.55.5362.8743 • Fax 52.55.5362.8743
www.safholland.com.mx

info@safholland.com