



# AD SERIES SUSPENSIONS

## SERVICE BULLETIN



### AD Series Suspensions

### Axle Alignment Welding and Torque Specifications for Pivot Connections

March 1, 2002

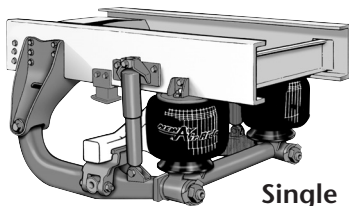

Single  
AD-123/126/130

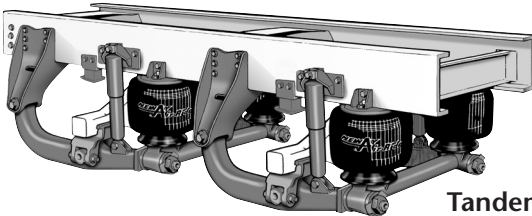

Tandem  
AD-246/252/260

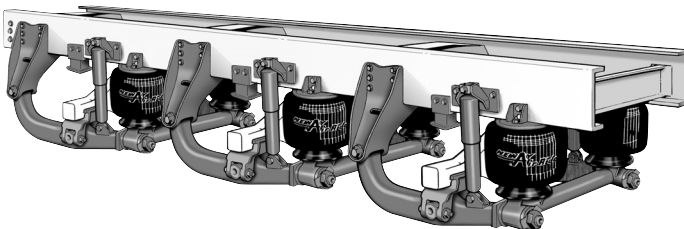

Tridem  
AD-369/378/390

**IMPORTANT: For proper installation and preventative maintenance of the AD Suspension Pivot Connection, the following is recommended.**

#### 1. OEM INSTALLATION

Follow Procedures and Specifications listed under OEM Axle Alignment Procedures (page 2).

#### 2. DEALER PRE-DELIVERY INSPECTION

It is recommended that the Dealer check for proper torque of all pivot connections prior to delivery of the truck to assure that connections are torqued to the recommended specifications listed in Table 1 - page 3.

#### 3. CUSTOMER PREVENTATIVE MAINTENANCE

It is recommended that the customer check for proper torque of all pivot connections after the first 100 hours of service or 5,000 miles, whichever ever comes first and thereafter at 50,000 mile intervals, every routine P.M., or brake relining (Reference AD Series Maintenance Manual #94100719, XL-AK383-01 or Torque Spec Decal)

**IMPORTANT: Be certain torque decal is attached to vehicle near suspension (Figure 1). New torque specification decals are available from Holland - Part No. 90044236, XL-AK399-01 (Figure 4).**

## OEM AXLE ALIGNMENT PROCEDURES

**NOTE:** The following steps assumes that the pivot connection is assembled with the proper hardware based on the frame width and frame bracket type specified for the application.

Perform the following procedures for each axle.

1. Determine whether the frame bracket is “fixed” (alignment block centered and welded to the frame bracket by Holland Neway) or “adjustable” (alignment block shipped loose by Holland Neway) (Fig. 2).

**NOTE:** Typically, suspension kits are shipped to the OEM with one frame bracket “fixed” and one frame bracket “adjustable”. Some OEM’s however specify both frame brackets as “adjustable”.

2. Holland Neway recommends that the chassis be set at the specified Ride Height prior to axle alignment (Fig 1).

3. “Fixed” frame bracket – torque pivot connection to the specifications listed in Table 1 - page 3.

4. “Adjustable” frame brackets – adjust axle alignment by sliding alignment blocks fore/aft (Fig. 2). Torque to specifications listed in Table 1 - page 3.

5. Weld alignment blocks on both sides of the adjustable frame bracket (Fig. 2).

**IMPORTANT: A minimum 3 minute cool down period is required after welding connection before re-applying torque to pivot bolt nut.**

6. Re-torque the cooled down pivot connection on the “Adjustable” frame bracket to the specifications listed in Table 1 - page 3.

**Figure 1. Installed AD Series Suspension**

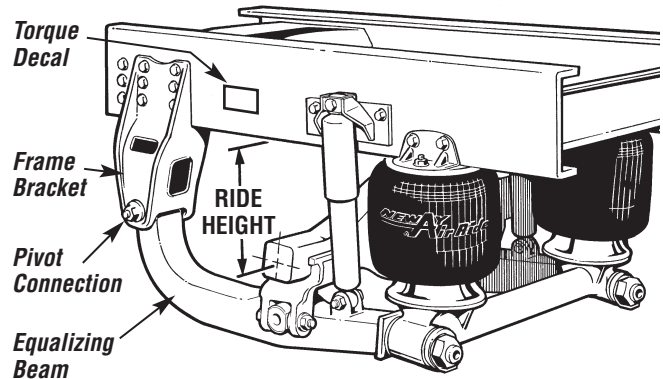

**Figure 2. “Adjustable” Frame Bracket**

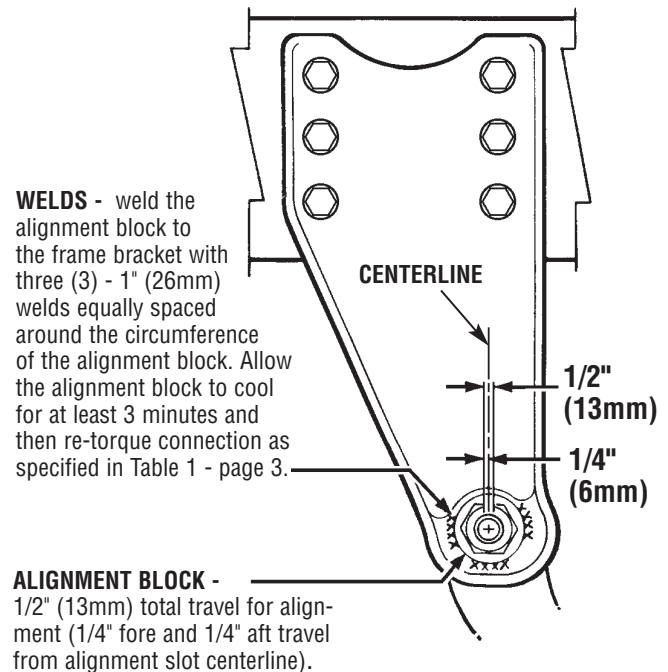

Table 1

RECOMMENDED TORQUE SPECIFICATIONS FOR AD SERIES SUSPENSION PIVOT CONNECTIONS	
<p><b>GENERAL INFORMATION</b></p> <ul style="list-style-type: none"> <li>• <b>Torque specifications listed are applied to the nut.</b></li> <li>• <b>Torque specifications: +/- 5% tolerance</b></li> <li>• <b>Lubricated Vs. Non-Lubricated Threads</b> – The torque specifications stated are for lubricated and non-lubricated fasteners. Holland defines lubricated vs. non-lubricated as follows: <ul style="list-style-type: none"> <li>• <b>Lubricated</b> – a bolted connection, such as the pivot bolt/nut arrangement, that has some form of friction modifier or lubricant pre-applied or applied to the thread surfaces, providing a lower torque requirement for a predetermined clampload.</li> <li>• <b>Non-Lubricated</b> – a bolted connection, either new or in service, that has little or no lubricant on the thread surfaces. Typically, this applies to bolted connections that have been in service for a certain length of time where the original protective coating has evaporated or deteriorated due to environmental exposure. Thus, a “non-lube” torque specification is commonly required for in-service torque check or retorquing procedures. A “non-lube” specification could be required for new installations if the pivot bolt has seen sufficient shelf life to allow for evaporation and deterioration of the protective coating.</li> </ul> </li> </ul> <p><b>NOTE: Use of special lubricants with friction modifiers, such as Anti-Seize or Never-Seize, without written approval from Holland Engineering will void warranty and could lead to premature bolt failure or other component issues.</b></p>	
<p><b>SUSPENSION MODELS:</b>  <b>AD-123 / 246 / 369 and AD-126 / 252 / 378</b>  <b>1 1/8" - 7 Pivot Connection Bolt</b></p> <hr/> <p><b>OEM Installation</b> – 600 ft. lbs.* for lubricated threads or 800 ft. lbs.* for non-lubricated threads.</p> <hr/> <p><b>Dealer Pre-Delivery Inspection</b> – 600 ft. lbs.* for lubricated threads or 800 ft. lbs.* for non-lubricated threads. Threads may be lubricated or non-lubricated depending on OEM installation procedures. Check with the Truck OEM to confirm lubricated or non-lubricated threads.</p>	<p><b>SUSPENSION MODELS:</b>  <b>AD-130 / 260 / 390</b>  <b>1 1/4" - 7 Pivot Connection Bolt</b></p> <hr/> <p><b>OEM Installation</b> – 700 ft. lbs.* for lubricated threads or 900 ft. lbs.* for non-lubricated threads.</p> <hr/> <p><b>Dealer Pre-Delivery Inspection</b> – 700 ft. lbs.* for lubricated threads or 900 ft. lbs.* for non-lubricated threads. Threads may be lubricated or non-lubricated depending on OEM installation procedures. Check with the Truck OEM to confirm lubricated or non-lubricated threads.</p>
<p><b>*Torque Specification: ± 5% Tolerance</b></p>	

Figure 3. Pivot Bolt Torque Lubrication Requirements - Old Style vs. New Style Identification



Figure 4. New AD Series Torque Specification Decal

**AD SERIES SUSPENSION TORQUE SPECIFICATIONS**

Fastener Size	Pivot Connection*		Transverse Beam**	Shock Absorber	Air Spring Attachments
	AD-123/126	AD-130			
	1 - 1/8"	1 - 1/4"	2 - 1/4"	3/4"	3/4"
Torque Ft. Lbs. (Nm)	600 (813)	700 (949)	525 (711)	150 (203)	35 (47)

ALL TORQUE SPECIFICATIONS ARE ± 5%. TORQUES ARE WITH CLEAN, LUBRICATED THREADS. ALWAYS APPLY TORQUE TO NUT IF POSSIBLE.

**\* IMPORTANT: SEE PIVOT BOLT HEAD**

Pivot Bolt Head marked "NEWAY" REQUIRES lubrication.

Pivot Bolt Head marked "HOLLAND NEWAY" DOES NOT REQUIRE lubrication.

**\*\*AFTER APPLYING PROPER TORQUE TO THE TRANSVERSE BEAM NUT, FOLD THE WASHER TAB OVER A FLAT SIDE OF THE NUT.**

**REQUIRED RE-TORQUING SCHEDULE:**

- ALL FASTENERS AFTER FIRST 100 HOURS OF SERVICE OR 5,000 MILES.
- 50,000 MILE INTERVALS, ROUTINE P.M., OR BRAKE RELINING.

Copyright © 2002 • The Holland Group, Inc.  
900 44 236 • XL-AK399-01  
GO THE DISTANCE.

HOLLAND USA, INC.  
1950 Industrial Blvd. • P.O. Box 425 • Muskegon, MI 49443-0425  
Phone 888-396-6501 • Fax 800-356-3929  
www.thehollandgroupinc.com

Copyright © April 2002 • The Holland Group, Inc.

<b>Holland USA, Inc. Facilities:</b>	<b>Holland International, Inc.</b>	<b>Holland Hitch of Canada, Ltd.</b>	<b>Holland Equipment, Ltd.</b>	<b>Holland Hitch Western, Ltd.</b>
Denmark, SC    Muskegon, MI	Holland, MI	Woodstock, Ontario • Canada	Norwich, Ontario • Canada	Surrey, British Columbia • Canada
Dumas, AR    Warrenton, MO	Phone: 616-396-6501	Phone: 519-537-3494	Phone: 519-863-3414	Phone: 604-574-7491
Holland, MI    Wylie, TX	Fax: 616-396-1511	Fax: 800-565-7753	Fax: 519-863-2398	Fax: 604-574-0244

Ph: 888-396-6501 Fax: 800-356-3929