

SAF Trailer Air and Mechanical Suspension Axle Systems

Product Change Notice for SAF Trailer Drum Brake Axle Camshaft Bearings

SAF-HOLLAND has made product improvement changes to the SAF trailer drum brake axle camshaft assembly.

Please Note:

Effective with shipments November 2012

The cam/slack bearing assembly fastens to a new welded axle bracket with (4) four bolts and lock nuts in place of (4) self-threading bolts (OLD STYLE). These component changes will not change fit, form or function.

Effective with shipments March 2014

The cam/spider bushing has changed from a two-piece plastic bushing design (OLD STYLE) to a one-piece sintered metal bushing design with seals (NEW STYLE). These component changes will not change form or function.

OLD STYLE

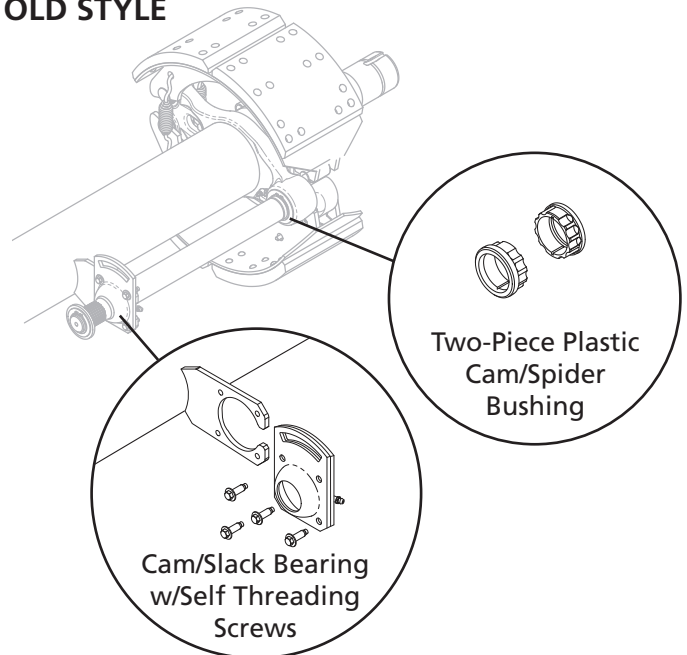

NEW STYLE

