

Installation Instructions

SAF Tire Pilot Plus (TPP)

Mechanical to Electronic Control Module

The following instructions provide the necessary information to be able to replace the TPP mechanical regulator assembly with the TPP electronic controlled module (ECM) (**Figure 1**).

⚠ WARNING Failure to properly support and secure the vehicle and axles prior to commencing work could create a crush hazard which, if not avoided, could result in death or serious injury.

⚠ CAUTION Before beginning work on the tire inflation system, it is necessary to drain the trailer air tank. Failure to drain the air tank could result in minor injury.

Removal and Installation

1. Drain trailer air tank.
2. Disconnect the power from the mechanical control box.
3. Disconnect the 1/4" air lines from the input and output of the mechanical control box (**Figures 2 and 3**).
4. Remove mechanical control box including the bracket.

Figure 2



Figure 3

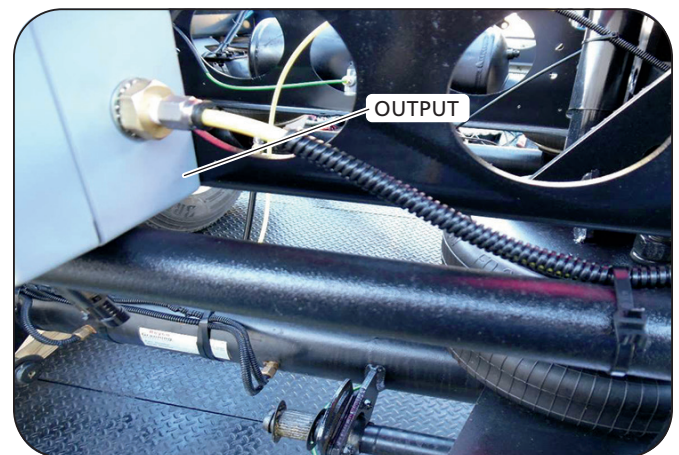

Figure 1



5. Locate the ABS power cable and disconnect the jumper harness installed between the 5-pin connectors.
6. Remove the old wiring harness section connected to the ABS adapter (**Figure 4**).
7. Leave the old wiring harness section connected to the LED light. This part of the harness is connected to pins C and D of the 4-pin flat connector.
8. Using the included hardware, mount the ECM assembly with bracket to the location where the mechanical control box was mounted (**Figure 5**).
9. Reconnect the air lines to the ECM. Connect the air line from the PPV to port 2 (input supply pressure) on the ECM. Connect the air line to the axles to Port G (output to tires) on the ECM (**Figures 6 and 7**).

NOTE: Connecting the air lines to the correct port on the ECM is critical to proper operation.

Figure 5

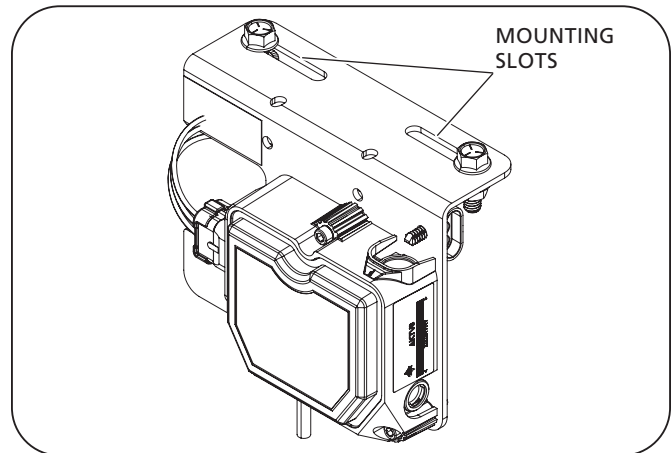

Figure 6

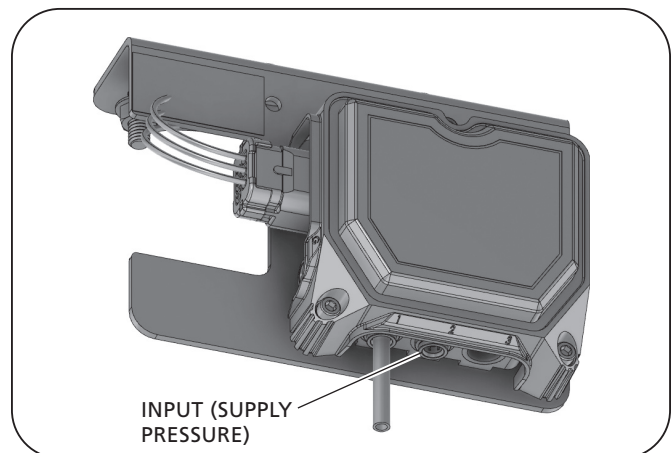

Figure 4

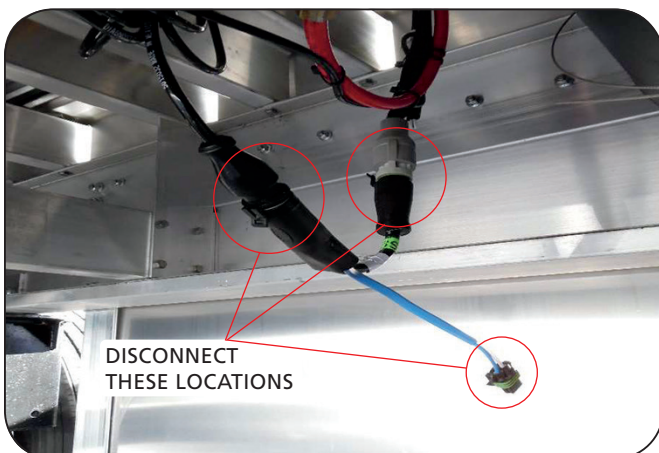
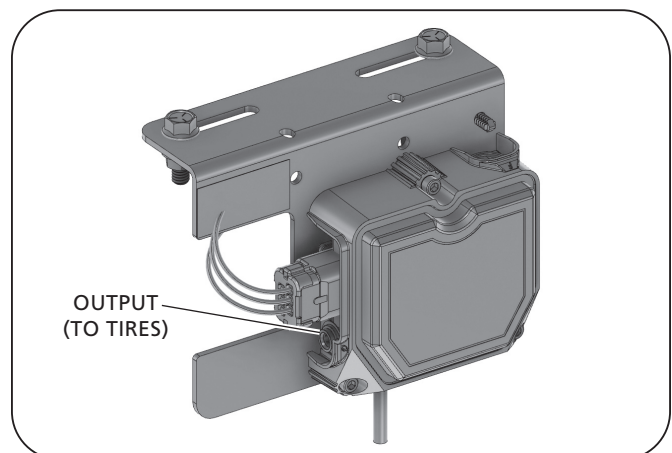

Figure 7



10. Connect the new ABS adapter to each side of the ABS power cable. Use a zip tie over the top of the tab connector on the harness to secure the connection (**Figure 8**).
11. Connect the 3-pin harness from the ABS adapter to the mating connector on the back of the ECM. Secure wiring as necessary (**Figure 9**).
12. Locate the 2-pin flat connector for the LED light. The LED light wiring can be re-ran all the way to the front of the trailer if convenient. Otherwise locate the existing wiring and make a butt-splice connection. The new harness will have yellow wiring on the positive 12 volt wire and white on the ground. The existing light harness should have black insulation color for positive LED and white insulation color for ground. Use some di-electric grease on the butt-splice connector and crimp with a proper crimper. Use shrink tubing or a shrink connector to seal the exposed wiring from the elements and prevent corrosion.
13. Secure any loose wiring.
14. Close the air tank drain.
15. Replace all tire hoses with a black wrap with new tire hoses with yellow wrap provided in kit. Tire hoses with a black wrap should be disposed. See Installation and Operation manual XL-AS20015BM-en-US for details.

Figure 8



Figure 9

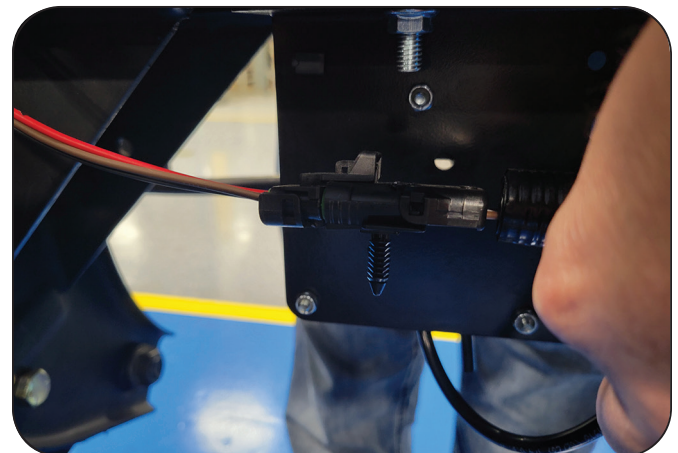

Startup and system check

1. Supply power and air to the trailer
2. Check for air leaks at the connection points to the ECM during operation. A mild soap and water solution can be used if necessary. Leaks can also be checked with the Tire Pilot Plus app found in the Play Store or Apple Store. If the TPP system is operational for 5-7 minutes continuously, the TPP app will report a leak in the diagnostic portion of the app, if a leak is present. Refer to XL-AS20015BM-en-US for instructions on downloading, connecting, and using the mobile app.
3. Verify through the TPP app that the system is operational and the tire pressures are near the desired pressure. You may let the Tire Pilot Plus system adjust the tire pressure to the programmed setpoint at this time. If not using the TPP app, let the trailer sit idle with power and air supplied for approximately 10 minutes to inflate and equalize the tire pressures. Make sure the LED warning light is off during this time.
4. With the TPP app on the status page, press the Light Test button near the bottom of the page (**Figure 10**). The LED light at the front of the trailer should come on for 5 seconds, and then go off. This will verify the light is functioning correctly. If the light does not come on, verification of the light wiring will need to be completed. If not using the app, power off the ECM for 10 seconds. Once power is applied again to the ECM, the light will come on for 5 seconds and go off.

Figure 10

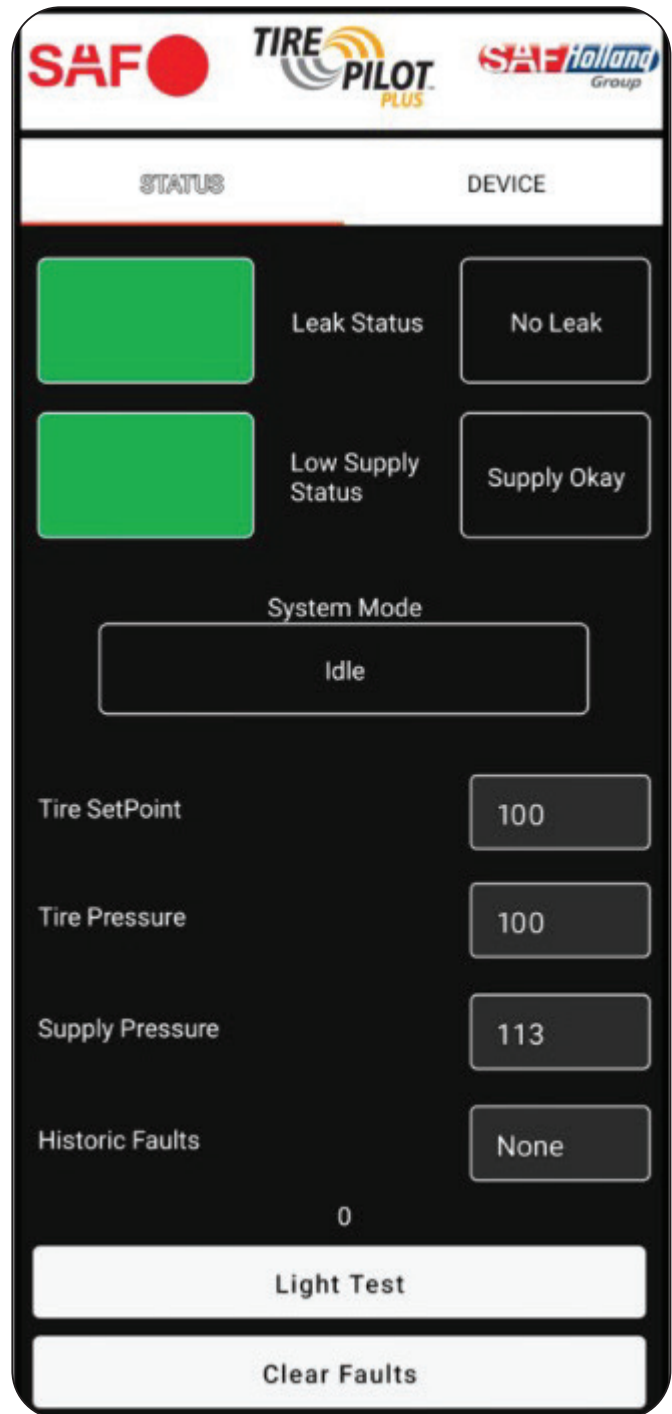

5. After the system is checked, has no leaks and an operational warning light, then disconnect the power and air from the trailer and return the trailer to service.

NOTE: Normal operation of the ECM is to check the air pressure in the tires and then exhaust air from the tire hoses back to the ECM. During this operation a series of clicks from the ECM solenoids can be heard and then the sound of air exhausting out of the side of the ECM from the high flow exhaust port (**Figure 11**). Reference XL-AS20015BM-en-US for full system installation or further troubleshooting information.

Figure 11

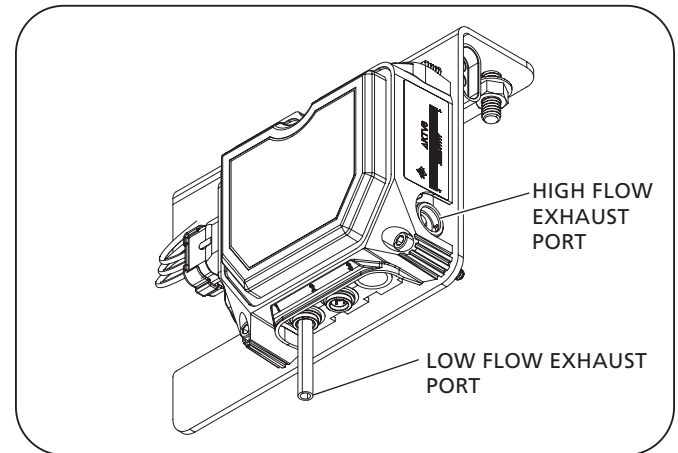



From fifth wheel rebuild kits to suspension bushing repair kits, SAF-HOLLAND Original Parts are the same quality components used in the original component assembly.

SAF-HOLLAND Original Parts are tested and designed to provide maximum performance and durability. Will-fits, look-alikes or, worse yet, counterfeit parts will only limit the performance potential and could possibly void SAF-HOLLAND's warranty. Always be sure to spec SAF-HOLLAND Original Parts when servicing your SAF-HOLLAND product.

SAF-HOLLAND USA • 888.396.6501 • Fax 800.356.3929
www.safholland.us

SAF-HOLLAND CANADA • 519.537.3494 • Fax 800.565.7753
WESTERN CANADA • 604.574.7491 • Fax 604.574.0244
www.safholland.ca

SAF-HOLLAND MEXICO • 52.55.5362.8743 • Fax 52.55.5362.8743
www.safholland.com.mx

info@safholland.com