

Installation and Operation Manual

SAF-HOLLAND® Tire Pilot™ Plus System

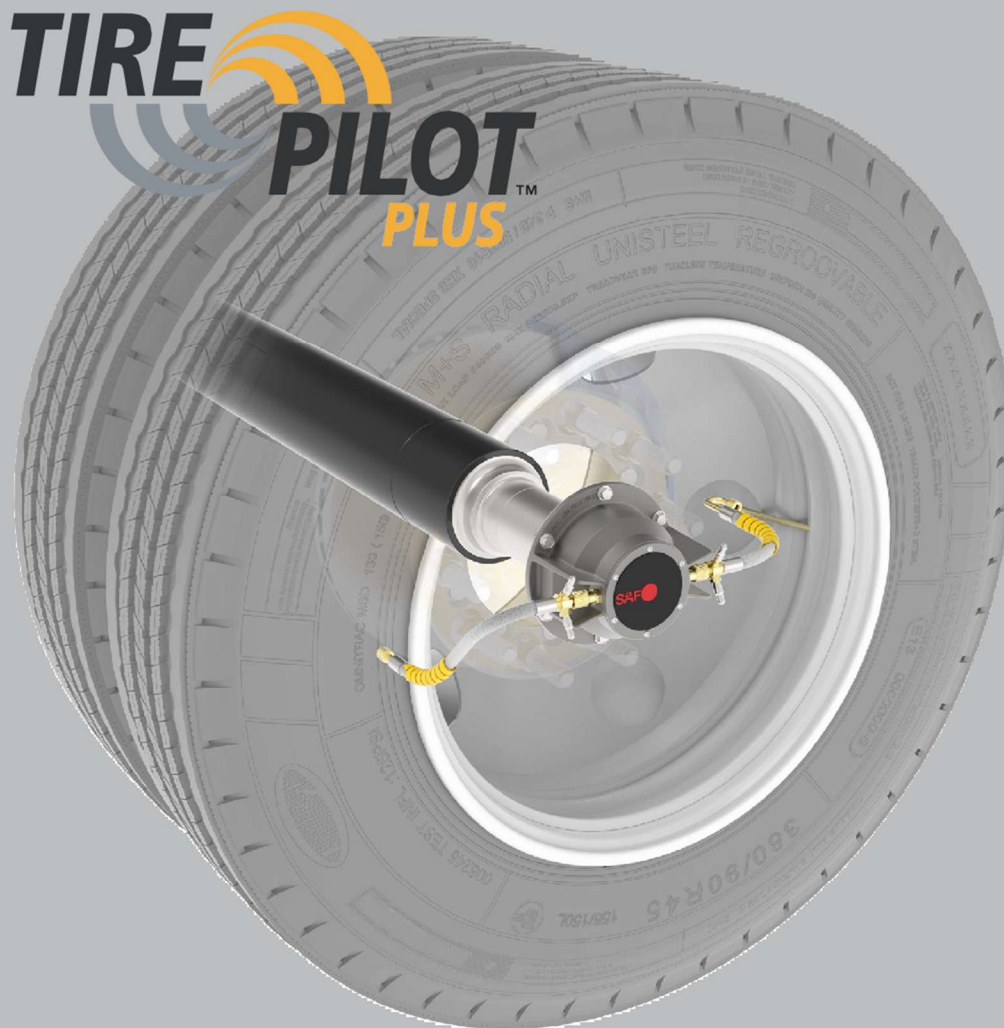

Contents	Page
Introduction	2
Warranty	2
Notes, Cautions, and Warnings	2
Section 1 – General Safety Instructions.....	3
Section 2 – Tire Pilot Plus Identification.....	4
Section 3 – Installation Instructions.....	5

Contents	Page
Section 4 – Multi-Axle Trailer Installation.....	12
Section 5 – System Inspection	13
Section 6 – Performance Testing	13
Section 7 – Electronic Regulator Assembly Mobile APP.....	14
Section 8 – Troubleshooting.....	16

Introduction

This manual provides information necessary for the installation of the SAF-HOLLAND Tire Pilot Plus tire inflation system.

The Tire Pilot Plus uses air drawn from the tractor to pressurize the system.

Read this manual in its entirety before installing this product. Updates to this manual, which are published as necessary, are available on the internet at www.safholland.us.

When replacement parts are required, SAF-HOLLAND highly recommends the use of only SAF-HOLLAND Original Parts. A list of technical support locations that supply SAF-HOLLAND Original Parts and an Aftermarket Parts Catalog are available on the internet at www.safholland.us or contact Customer Service at 888-396-6501.

Warranty

Refer to the complete warranty for the country in which the product will be used. A copy of the written warranty is included with the product or available on the internet at www.safholland.com.

Notes, Cautions, and Warnings

Before starting any work on the unit, read and understand all the safety procedures presented in this manual. This manual contains the terms “NOTE”, “IMPORTANT”, “CAUTION”, and “WARNING” followed by important product information. These terms are defined as follows:

NOTE: Includes additional information to enable accurate and easy performance of procedures.

IMPORTANT: Includes additional information that if not followed could lead to hindered product performance.

CAUTION Used without the safety alert symbol, indicates a potentially hazardous situation which, if not avoided, could result in property damage.

▲ CAUTION Indicates a potentially hazardous situation which, if not avoided, could result in minor or moderate injury.

▲ WARNING Indicates a potentially hazardous situation which, if not avoided, could result in death or serious injury.

I. Safety Instructions

General and Servicing Safety Instructions

- Read and observe all Warning and Caution hazard alert messages. The alerts provide information that can help prevent serious personal injury, damage to components, or both.

⚠ WARNING Failure to follow the instructions and safety precautions in this manual could result in improper servicing or operation leading to component failure which, if not avoided, could result in death or serious injury.

- All maintenance should be performed by a properly trained technician using proper/special tools, and safe procedures.

NOTE: In the United States, workshop safety requirements are defined by federal and/or state Occupational Safety and Health Act (OSHA). Equivalent laws could exist in other countries. This manual is written based on the assumption that OSHA or other applicable employee safety regulations are followed by the location where work is performed.

- Properly support and secure the vehicle from unexpected movement when servicing the unit.

⚠ WARNING Failure to properly support and secure the vehicle and axles prior to commencing work could create a crush hazard which, if not avoided, could result in death or serious injury.

- Installation should be performed on an unloaded trailer if possible.

Operational and Road Safety Instructions

- Before operating vehicle, ensure that the maximum permissible axle load is not exceeded and that the load is distributed equally and uniformly.
- Observe the operating recommendation of the trailer manufacturer for off-road operation of the installed axles.

IMPORTANT: The definition of OFF-ROAD means driving on non-asphalt/non-concrete routes, e.g. gravel roads, agricultural and forestry tracks, on construction sites and in gravel pits.

IMPORTANT: Off-road operation of axles beyond the approved application design could result in damage and impair suspension system performance.

- In the event of suspension component failure, quickly reduce speed as safely as possible and remove the vehicle from traffic. If unable to remove vehicle from traffic, follow DOT safety requirements regarding emergency situations.
- Contact a qualified towing and/or service company to assist in repairing the vehicle or to move it to a qualified repair facility.

2. Tire Pilot Plus Identification

In order to identify a parts list for your system the following information is required:

- Number of axles
- Tire pressure setting
- Single Tires or Dual Tires
- Suspension Serial number(s)
- Tapered or Parallel Spindle

2.1 Sliding Suspension Model Identification

The sliding suspension serial tag is located on the rear crossmember (**Figure 2**).

NOTE: This manual applies to all suspension models. However, determine your specific model number, write that information below and refer to it when obtaining information or replacement parts (**Figure 3**).

2.2 Fixed Frame Model Identification

The fixed frame suspension serial tag is located on the frame bracket (**Figure 4**).

NOTE: This manual applies to all suspension models. However, determine your specific model number, write that information below and refer to it when obtaining information or replacement parts (**Figure 3**).

The Tire Pilot Plus Electronic Regulator Assembly also has a serial number tag on the control box, and a part number tag located on the outside as illustrated in **Figure 1**.

Figure 1

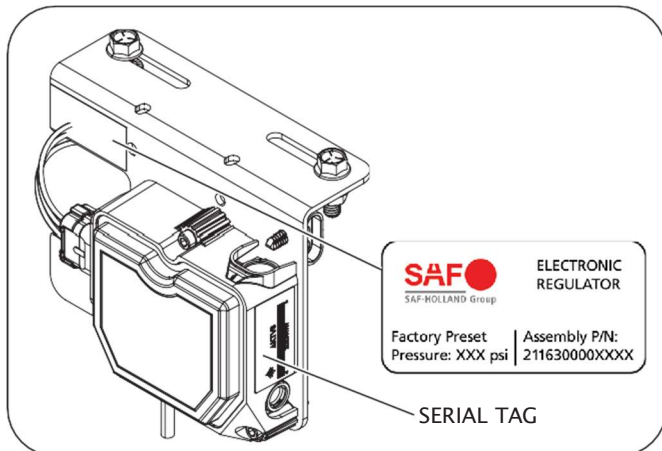

Figure 2

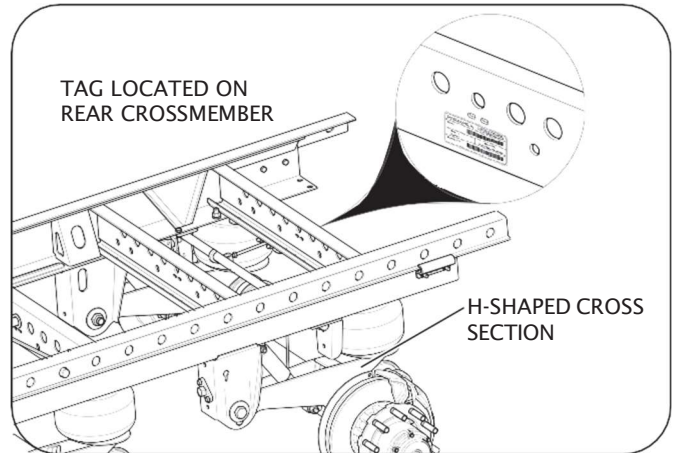

Figure 3

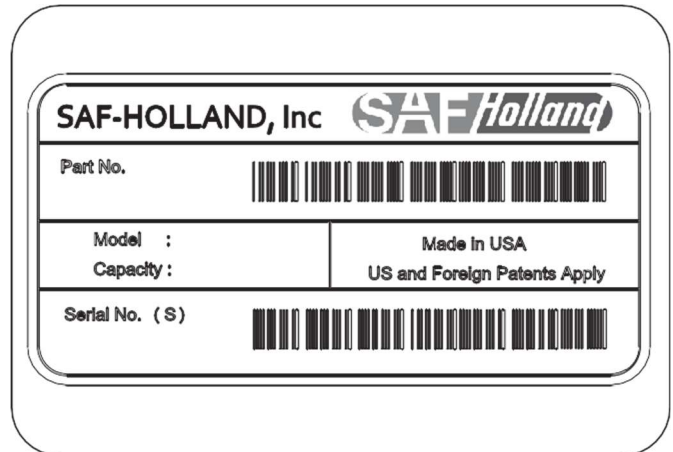
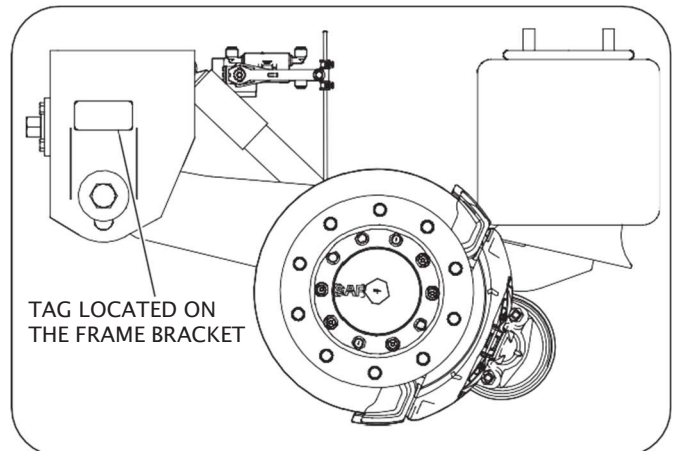

Figure 4



3. Installation Instructions

NOTE: If your axles are prepped from SAF-HOLLAND with spindle plugs and vents skip to number 8. If your axle does not have a tapped hole, one will need to be drilled. If a tapped hole is present skip to number 3.

1. On the top dead center or 12 o'clock position of the axle mark the centerline. At this centerline mark, use an 'R' drill bit to drill a hole using tap fluid or light cutting oil. While drilling, periodically clean away metal shavings. Use a telescoping magnet to go inside of the axle tube and clear any remaining metal shavings (**Figure 5**).

NOTE: An axle drilling fixture is available if required. Contact SAF-HOLLAND customer service for details.

2. Using a 1/8" - 27 NPSF tap and cutting oil, tap the hole drilled in step 1.
3. Insert 1/4" DOT tubing through the center hole in the axle. Feed the air line through the axle and out of the curbside spindle end. Leave approximately 6" of air line outside the spindle. Alternatively, a weld liner, fish tape, or other method can be used to pull the tubing from one spindle end to the center hole (**Figures 6 and 7**).

NOTE: Leave enough air line out of the center hole to reach desired location for the regulator assembly and account for suspension travel.

CAUTION

Protective loom (not shown) should be used over the air line within the axle. Failure to install a protective loom could result in chaffing the air line which, if not avoided could shut down the Tire Pilot Plus system.

Figure 5



Figure 6

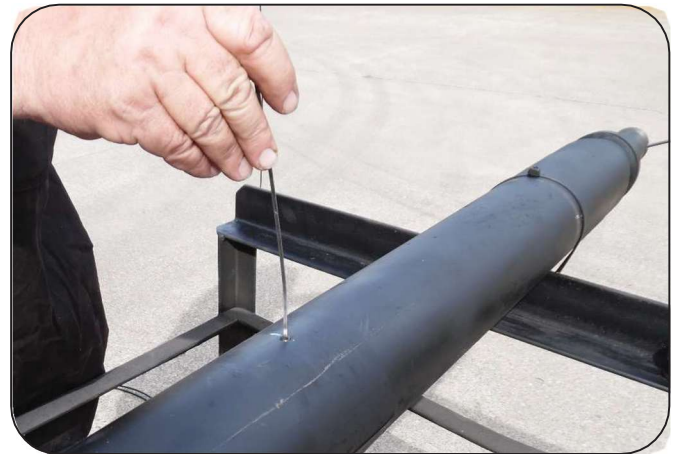
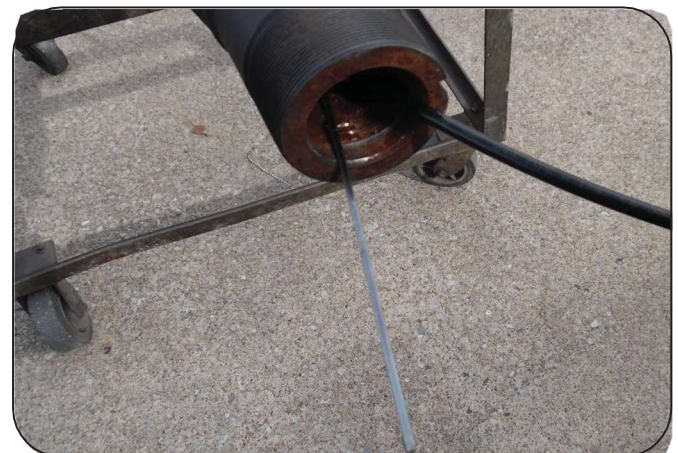

Figure 7



4. Insert 1/4" DOT tubing through from the curbside to the roadside spindle. Leave approximately 6" of air line outside of both spindles (**Figure 8**).

NOTE: Use of an 1/8" metal rod to assist in getting the 1/4" tubing across the axle could be necessary (**Figure 8**).

CAUTION

Protective loom (not shown) should be used over the air line within the axle. Failure to install a protective loom could result in chaffing the air line which, if not avoided could shut down the Tire Pilot Plus system.

5. Start on the roadside of the axle install the dual outlet spindle plug assembly. Ensure that both pieces of 1/4" tubing have been cut squarely. Trim off excess air line as necessary. Push 1/4" air line into fitting until it bottoms out in the push-to-connect fitting. Complete for both air lines and fittings (**Figure 9**). Repeat this step for curbside single fitting spindle plug.

Figure 8



Figure 9



- Insert the cylinder plug assembly into the axle. Align the vent notch to the 12 o'clock position (**Figure 10**). Insert the spindle plug into the axle until the shoulder contacts the spindle bore. Drive the spindle plug into the axle unit fully seated against the face of the spindle. Check for gaps with a 0.050" feeler gauge. Repeat this step for the roadside spindle with the single fitting spindle plug (**Figure 11**).

NOTE: If the axle is a parallel spindle with cross drilled holes, take care to locate the cross drilled holes in the windows of the spindle plug.

CAUTION

Axle vents must be installed, due to the Tire Pilot Plus system not venting through the wheel end. Failure to do so could cause build up of pressure which, if not avoided, could create wheel end lube leaks.

- Apply pipe thread compound to the vent fitting threads if not present. Remove the compression brass nut and O-ring from the vent. Slide vent fitting, brass nut and O-ring over the air line coming out of the center hole in the axle. Feed the excess air line through the vent. Thread the vent fitting body into the axle hand tight plus additional rotation until the vent is parallel to the axle (**Figure 13**). Tighten the compression nut by hand and then use a wrench to tighten an additional 1/2 turn (**Figures 12 and 13**).

CAUTION

Leave 12-18 inches of slack in the tube through the vent assembly to allow for suspension travel. Failure to do so could cause excessive stress on the air lines which, if not avoided, can damage air lines.

Figure 11



Figure 12

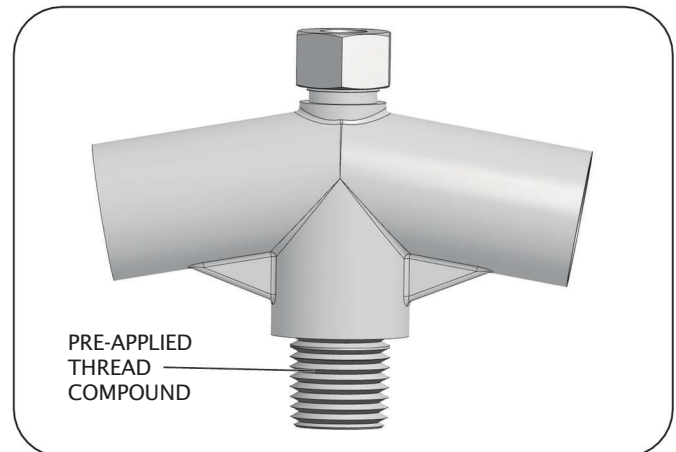

Figure 10

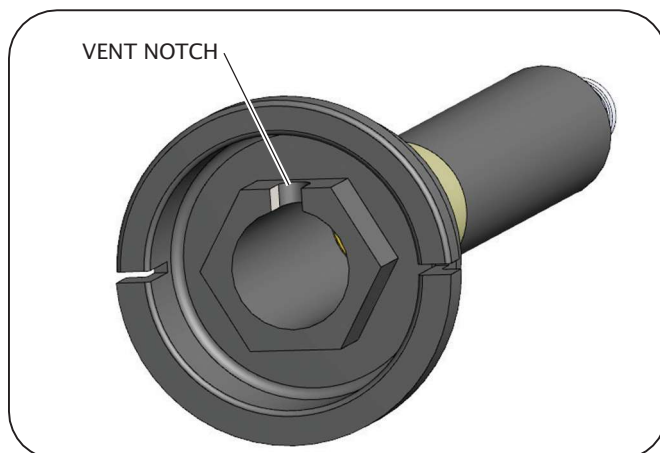
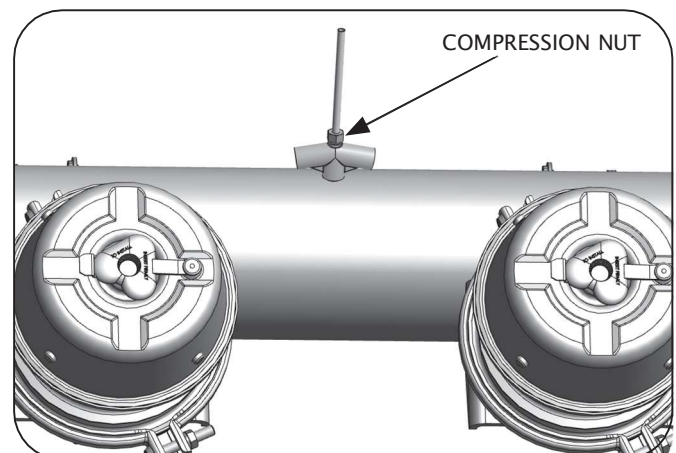

Figure 13



8. Install the pressure protection valve to the air tank. Take care to insure the 'in' side of the valve is connected to the air tank. A dedicated pressure protection valve is required for the tire inflation system which is included in the kit (**Figure 14**). The use of thread sealant is recommended to reduce leaking fittings.
9. Locate a secure location for mounting the electronic regulator assembly. Mount the electronic regulator assembly with hose and wiring connections facing down or to the side. Use the mounting slots provided on the bracket with included hardware. Recommended location on sliding suspensions is the front or rear crossmembers. On fixed frame suspensions, the recommended location is the main trailer beam either in front of the suspensions, or just behind the suspensions (**Figure 15**).
10. Connect each axle air line together with a push to connect (**Figure 16**) T-fitting.
11. Connect air tank pressure protection valve air line to the electronic regulator input in the control box (**Figure 17**).

Figure 15

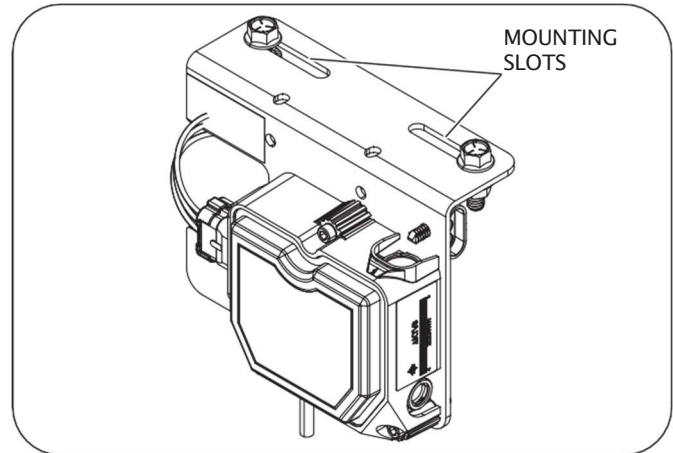
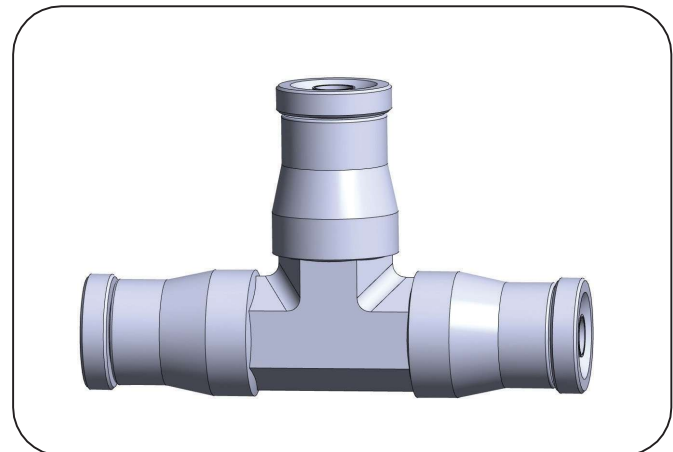

Figure 16



CAUTION If connections are mounted facing up, water and debris in the connections can cause trouble over time, especially in colder climates. Also, do not mount the electronic regulator assembly upside down. Internal components are sensitive to the mounting orientation. If not properly mounted the electronic regulator assembly can fail prematurely, shutting down the Tire Pilot Plus system.

Figure 14

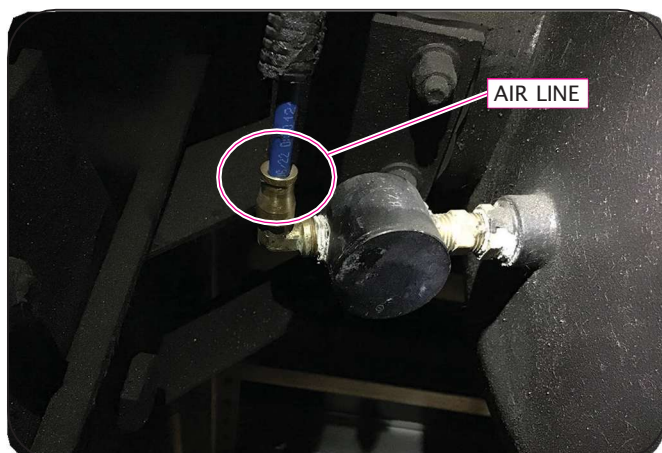
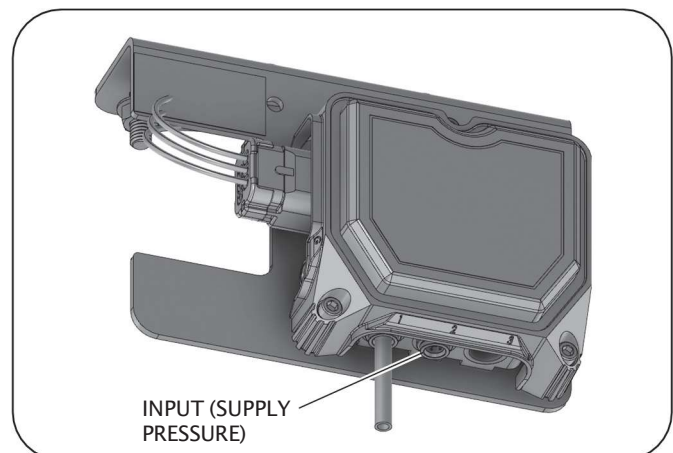

Figure 17



12. Connect each axle T-fitting to the electronic regulator output in the control box (**Figure 18**).
13. Secure air lines between axles, air tank, and electronic regulator control box with 6" cable ties. Securing the air lines to the brake hoses is recommended.

NOTE: Wire loom is recommended to protect air line from sharp corners on the trailer sub-frame.

CAUTION

Protective loom (not shown) should be used over the air line. Failure to install a protective loom could result in chaffing the air line which, if not avoided could shut down the Tire Pilot Plus system.

14. Locate the ABS power cable and disconnect as illustrated in **Figure 19**.
15. Install power adapter shown in **Figure 20**. Use dielectric grease in the connections if not already present. Connect the ends and secure with cable ties or clips.
16. Secure the ABS power adapter locking tab using a cable tie as illustrated in **Figure 21**.
17. Route the wiring harness through the trailer cross rails to connect the wiring to the electronic regulator control box.

CAUTION

If the electronic regulator is located on a sliding suspension, be sure to leave enough wiring loose to route along the factory coiled wires and hoses at the stinger bracket.

Figure 19

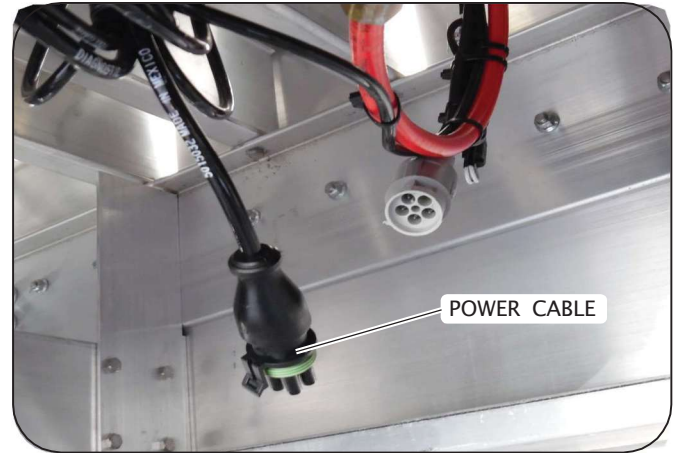

Figure 20

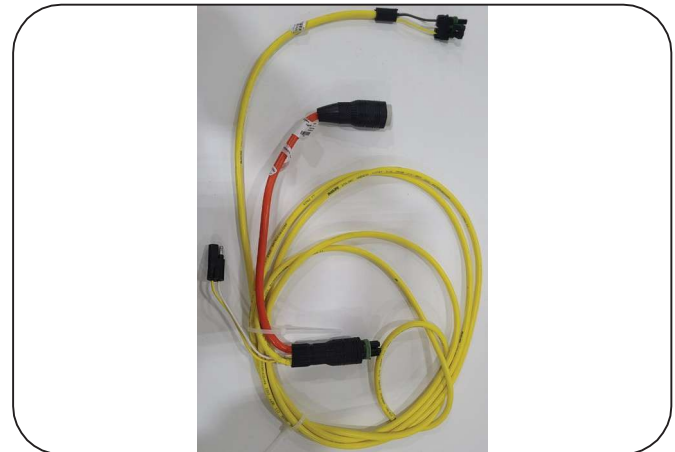

Figure 18

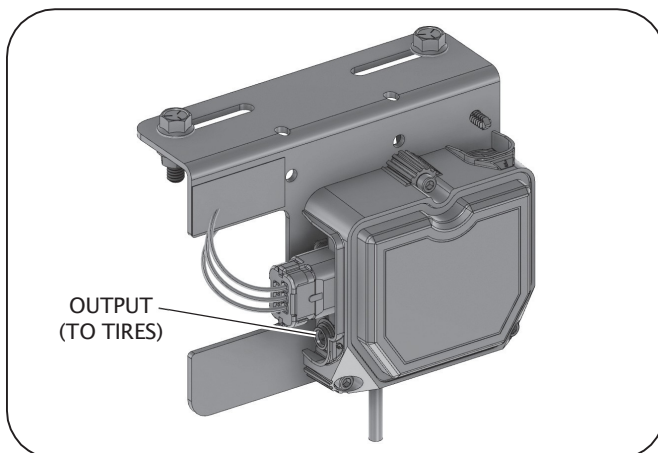

Figure 21



18. Run the wires for the trailer mounted warning light through the trailer crossmembers. Use cable ties to secure the wiring (**Figure 22**).
19. Mount the warning light on the roadside approximately six feet from the bottom of the trailer. Use appropriate water proof sealant on warning light screw holes if surface mounted. If a flush mount light is desired with hidden wires, push the LED light out of the plastic housing. Use the rubber grommet in a 3/4" diameter hole in the trailer to install grommet and light. Flush mount illustrated. (**Figure 23**). Connect wiring harness to light matching the wire colors. Use dielectric grease in the connectors. Connect the other end of the harness to the ABS adapter connector as illustrated in **Figure 20**.
20. Install the warning light decal directly above the warning light (**Figures 23 and 24**).

Figure 23



Figure 22

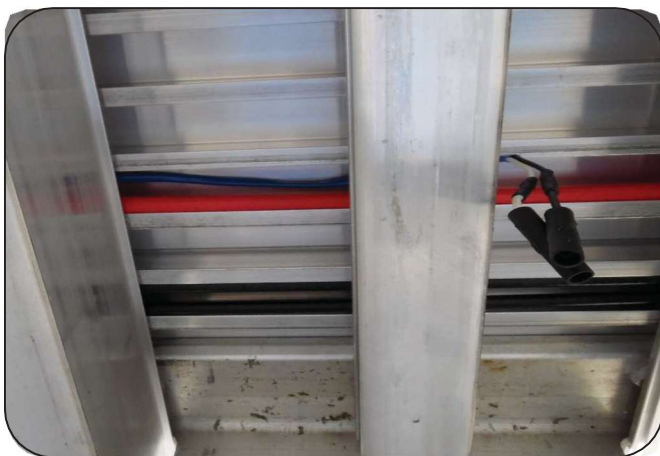

Figure 24



21. Install hubcaps to hubs if not pre-installed to your axles. Torque hubcap bolts in a opposing pattern to 12-16 ft-lbs. The latest version of the grease hubcap has a duckbill vent to assist with venting the hub cavity. This feature is also useful to troubleshoot an end of life rotary union.
22. If tire hoses are equipped with dual port fittings at the hubcap, ensure both flow through caps are installed and tightened to 1.5-3.0 in-lb on each tire hose (**Figure 25**). A loose or missing cap could allow debris to affect the sealing performance of the valve cores while checking tire pressure. Earlier tire hoses may not have additional ports and this step does not apply.
23. Install tire hoses by connecting the tire side first. Fittings only need to be hand tight. Over-tightening can cause damage to the seals inside the fittings and possible leaks.

CAUTION

Be certain to pay attention to the orientation of the hubcap, rim, and valve stem locations. If the orientation of the rim to hubcap is incorrect, premature failure of the tire hoses and/or damage to the rims can occur. **Figure 26** shows the proper orientation for a dual steel wheel application with 5 hand hole rims. **Figure 27** shows the proper orientation for an aluminum wide base single application. The hubcap fitting position is 90 degrees relative to the valve stem in **Figure 27**. **Figure 28** shows the proper orientation for dual steel wheels with 2 hand hole rims.

Figure 26



Figure 27



Figure 25

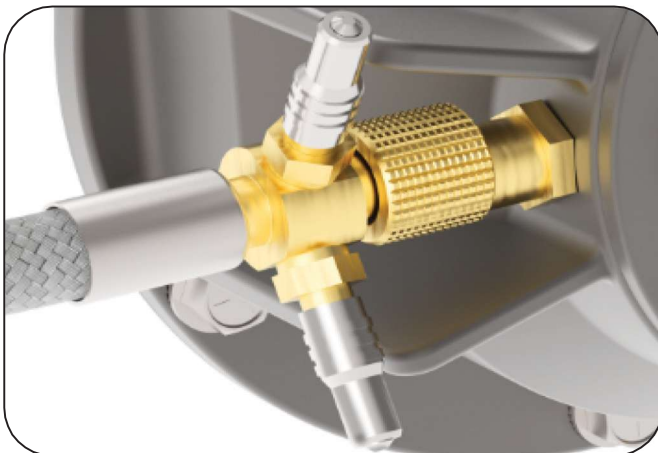

Figure 28



4. Multi-Axle Trailer Installation

1. A maximum of 8 tire hoses can be supported per ECM. A tri-axle trailer must have single tires to be able to use one ECM.

CAUTION

If more than 8 tire hoses are used per ECM, failure of one or more of the tire hose valves is possible, which could cause flat tires.

2. For trailers with more than 3 axles or for systems that require 2 different tire pressure settings, multiple regulator assemblies are required.
3. To install multiple regulators follow the steps in Section 3 with the following exceptions:
 - Install ABS Y-adapter cables in series for each regulator assembly (male connector on ABS adapter #1 to female connector on ABS adapter #2, **Figure 29**).
 - Install Led light for each regulator assembly.

Figure 29



5. System Inspection

1. Confirm 12 volt power supply and air supply to trailer. ABS system cycles with key to confirm power to the trailer.
2. Confirm electrical connector on the electronic regulator assembly is connected to the wiring harness.
3. Confirm air line input and output are connected to the electronic regulator assembly and input air pressure from the tank has a pressure protection valve installed.
4. Confirm system warning light is off.
5. Check for air leaks with a non-corrosive (soap/water) leak test solution at the following areas:
 - Pressure Protection valve
 - Air input to electronic regulator assembly
 - Air output from electronic regulator assembly
 - Tire hose connections
 - Axle inlet/vent assembly
 - Hubcap duckbill vent
6. Be certain to regularly drain the air tank of moisture. Build up of moisture in the air system can cause premature failure of the Tire Pilot Plus system. A water separator or other moisture control measures may be necessary in excessively humid or moist locations.
7. If the tire hoses are equipped with dual port fittings at the hubcap, manually check the tire pressure through the flow through cap. Prior to checking pressure, ensure the cap is clean of debris. If the tire hose does not have a dual port fitting, remove the hose, manually check tire pressure, re-install tire hose and check for leaks.

IMPORTANT: The air system shall be free of chemical additives such as lubricants, de-icers, or antifreeze products. The TPP system warranty may be voided if the air system is contaminated.

IMPORTANT: Tire pressure should be at or below regulator setting prior to system start-up. Failure to correctly set tire pressure prior to system start-up will result in reduced product performance.

NOTE: Normal operation of the ECM is to check the air pressure in the tires and then exhaust air from the tire hoses back to the ECM. During this operation a series of clicks from the ECM solenoids can be heard and then the sound of air exhausting out the side of the ECM from the high flow exhaust port (**Figure 30**).

Performance Testing

1. Make sure air and power are being supplied to the Tire Pilot Plus system. Voltage should be a minimum of 12 volts. Air pressure needs to be greater than the Tire Pilot Plus pressure setting. The minimum recommended air tank pressure is 10psi above the pressure setting.
2. To check function of the light, verify air and power to the system. The light should illuminate when power and air are first applied. Also, the light test portion of the app can be used. See section 7.
3. To leak check the system, install a pressure gauge with a shutoff valve up stream of it at the outlet of the control box. Verify air and power are present. Shut the valve. Leak rate should be less than 1 psi per minute. It is also possible to use the mobile app (refer to section 7). If the app does not register a leak during its cycling and pressure checks for the first 5 minutes of operation, the system is assembled properly.
4. To check the pressure setting, refer to section 7.
5. To verify air flow from system, first verify air and power to the system. Check air flow by disconnecting the output line from the electronic regulator assembly. Alternatively, remove the tire hose from the hubcap. Depress the check valve at the hubcap fitting with a small screwdriver to confirm air flow. It will be necessary to wait at least 1 minute after initial power and air is applied to the system for the system to cycle and perform a pressure check to determine if air is flowing. Light may illuminate during this test and require a power cycle to reset.

Refer to electrical diagram part number 42210013 and air schematic part number 42210012 for further help with system function or installation questions.

Figure 30

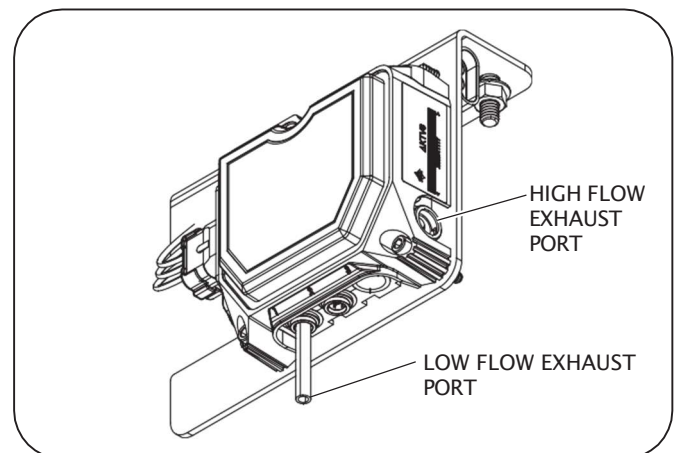

7. Electronic Regulator Assembly Mobile APP

1. Download the mobile application by visiting the Play store or Apple store.
2. Install the APP to your device.
3. Open the APP and select the device tab on the top (**Figure 31**).
4. Scan for the nearby device you would like to connect to and select it in the list by clicking the grey button. Be sure the 6 digit serial number in the device name matches the 6 digit number on the label on the side of the device.
5. Once connected, the grey button will turn green. Then select the status tab on the top. If you are having trouble connecting via bluetooth try clearing previous unused bluetooth connections. Also, you can connect to the device in the settings portion of your phone under bluetooth. Once the note appears that an app is required for this device, switch back to the app on your phone. If you continue to have difficulty connecting, try turning off other Bluetooth devices in the area. If connecting via bluetooth remains difficult, power off the ECM for 30 seconds, forget the device in the bluetooth settings and try again.

Figure 31

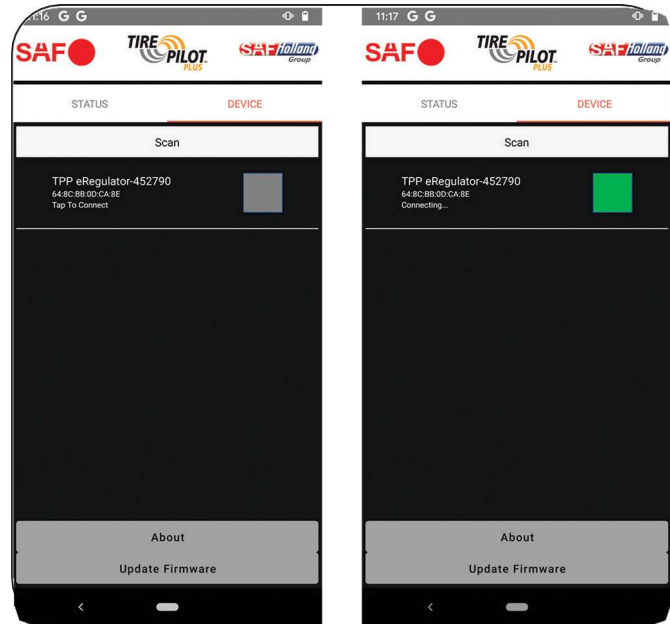

6. In the status tab you can review the following (**Figure 32**):
 - a. Leak Status
 - b. Low Supply Status
 - c. System Mode
 - d. Tire SetPoint
 - e. Tire Pressure
 - f. Supply Pressure
 - g. Historic Faults
7. In the status tab you can also clear the faults or test the light function. Once the light test button is pressed, the LED light will illuminate approximately 5 seconds and then turn off. To clear any faults present, simply press the clear faults button.

Figure 32

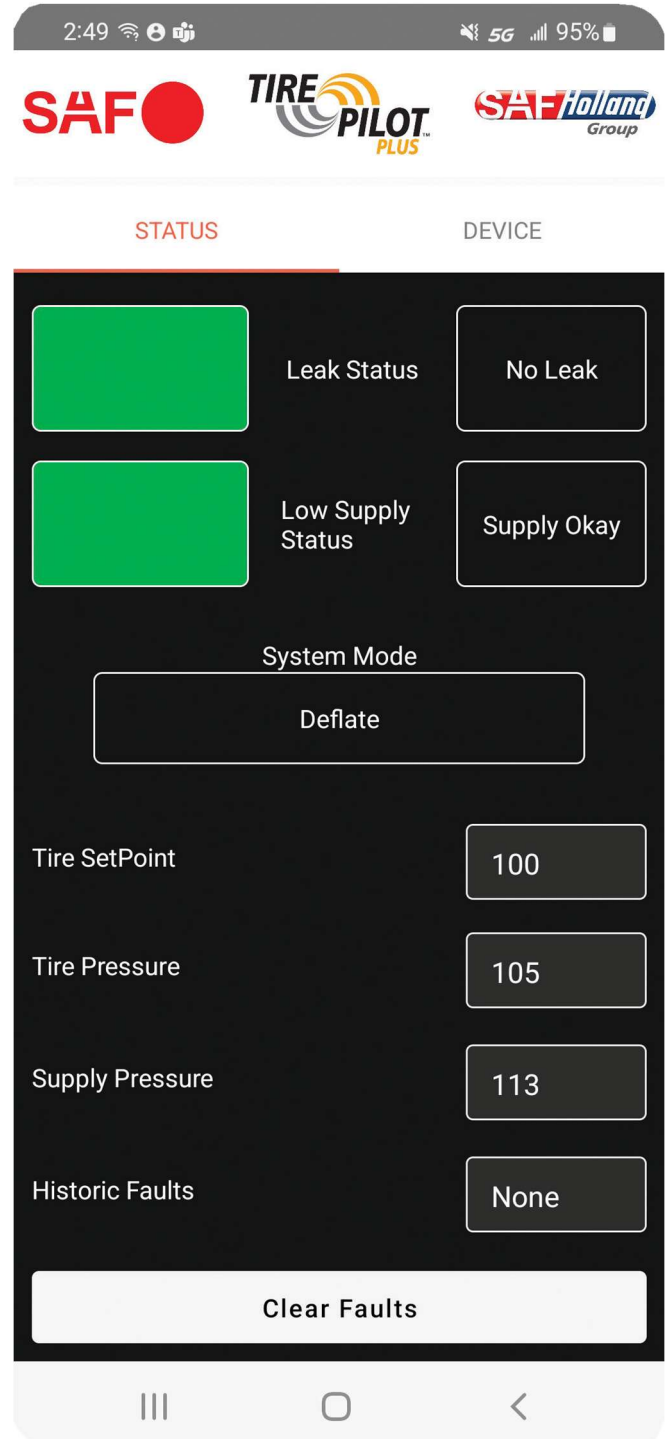

8. Troubleshooting Chart

PROBLEM	POSSIBLE CAUSE	POSSIBLE REMEDY
Tire Pressure LOW and Warning Light ON	Damaged tire, rim, and/or valve stem	Repair/replace tire, rim and/or valve stem
	Inadequate supply pressure	Supply pressure must be a minimum of 10psi greater than the highest tire pressure. Correct as necessary.
	Inadequate supply voltage	Supply voltage must be a minimum of 12V DC. Correct as necessary.
	Defective Pressure Protection Valve	Replace pressure protection valve Note: System cannot use the same PPV as the air suspension. A dedicated port on the air tank is required with a dedicated pressure protection valve.
	Loose/leaking air lines or fittings	Spray all air lines and fittings with soapy water and repair leaks as needed
	Leaking rotary union	Replace rotary union. Confirm leak by listening for air venting at the center axle vent or duckbill vent on the hubcap.
	Leaking tire hoses	Tighten or replace hoses. If equipped with dual port fittings, depress a leaky valve core to flush potential debris or re-seat seal. If valve core still leaks, replace valve core with Schrader-Pacific 054051000 or equivalent.
	Low tire pressure	Let the system inflate the tires up to the target pressure.
	Defective electronic controlled module	Replace ECM
Tire Pressure LOW and Warning Light is OFF	Inadequate supply pressure	Supply pressure must be a minimum of 10psi greater than the highest tire pressure. Correct as necessary.
	Inadequate supply voltage	Supply voltage must be a minimum of 12V DC. Correct as necessary
	Leaking rotary union	Replace rotary union. Confirm leak by listening for air venting at the center axle vent or duckbill vent on the hubcap.
	Leaking tire hoses	Tighten or replace hoses. If equipped with dual port fittings, depress a leaky valve core to flush potential debris or re-seat seal. If valve core still leaks, replace valve core with Schrader-Pacific 054051000 or equivalent.
	Tractor does not have constant power to the center pin of the 7way connector (constant blue)	Update tractor wiring to have constant power to the center pin of the 7way connector (ABS constant blue)
	Low tire pressure	Let the system inflate the tires up to the target pressure.
Tire Pressure HIGH and Warning Light is ON	Low supply pressure	Incoming pressure must be greater than 10psi above the highest tire pressure. Correct as necessary.
	Low supply voltage	Incoming voltage must be greater than 12V DC. Correct as necessary.
	Defective Pressure Protection Valve	Replace pressure protection valve Note: System cannot use the same PPV as the air suspension. A dedicated port on the air tank is required with a dedicated pressure protection valve.
	Loose and/or leaking air lines and/or fittings	Spray all air lines and fittings with soapy water and repair leaks as needed
	Leaking rotary union	Replace rotary union. Confirm leak by listening for air venting at the center axle vent or duckbill vent on the hubcap.
	Leaking tire hoses	Tighten or replace hoses. If equipped with dual port fittings, depress a leaky valve core to flush potential debris or re-seat seal. If valve core still leaks, replace valve core with Schrader-Pacific 054051000 or equivalent.
	Tires over-inflated	Manually reduce the tires air pressure below the target setpoint. Let the system inflate the tires up to the setpoint.
Tire Pressure HIGH and Warning Light is OFF	Tire over-inflation	Let system function with power and air, the system will relieve the tire pressure to the current setpoint.

PROBLEM	POSSIBLE CAUSE	POSSIBLE REMEDY
Tire Pressure in-spec and Warning Light is ON	Inadequate supply pressure	Supply pressure must be 10psi greater than the highest tire pressure. Correct as necessary.
	Inadequate supply voltage	Supply voltage must be a minimum of 12V DC. Correct as necessary
	Defective Pressure Protection Valve	Replace pressure protection valve Note: System cannot use the same PPV as the air suspension. A dedicated port on the air tank is required with a dedicated pressure protection valve.
	Loose/leaking air lines or fittings	Spray all air lines and fittings with soapy water and repair leaks as needed
	Leaking rotary union	Replace rotary union. Confirm leak by listening for air venting at the center axle vent or duckbill vent on the hubcap.
	Defective ECM	Replace ECM
Tire Pressure in-spec and Warning Light is OFF	System is working as designed, no issue	
Supply pressure in the app doesn't match the supply pressure on my gauge.	System is functioning as designed, no issue. Supply pressure is an estimation and can only be measured when air is flowing to the tires. When air is flowing to the tires, there is a pressure drop, so the supply readout in the app will always be lower than the static pressure when there is no flow. If the supply pressure measured is 2psi greater than the measured tire pressure, the ECM will function normally.	
Air Leak from axle vent and/or air leak from the duckbill vent in the hubcap assembly	Damaged/loose airlines or connections inside the axle	Remove spindle plug assemblies, inspect air line connections and repair as necessary
	Leaking rotary union	Replace rotary union. Confirm leak by listening for air venting at the center axle vent or duckbill vent on the hubcap.
	Loose and/or leaking air lines and/or fittings	Spray all air lines and fittings with soapy water and repair leaks as needed
Air Leak from Tire Hose	Overtightened connections	Tire hose fittings should be hand tightened. Over-tightened fittings can damage the o-rings inside the fitting. Inspect o-rings for damage and replace as necessary.
	Loose tire hose connection	Tighten the tire hoses hand tight at the valve stem first, then at the hubcap assembly.
	Valve core leaking at dual port fitting	Depress a leaky valve core to flush potential debris or re-seat seal. If valve core still leaks, replace valve core with Schrader-Pacific 054051000 or equivalent
Brake air tank de-pressurized or low pressure	Defective pressure protection valve	Replace pressure protection valve Note: System cannot use the same PPV as the air suspension. A dedicated port on the air tank is required with a dedicated pressure protection valve.
	Air leak between air tank and pressure protection valve	Spray all air lines and fittings with soapy water and repair leaks as needed
LED warning light flashing On and no other trouble found	Previous fast leak detected	Reset the module by cycling the power off then back on or clear the faults within the mobile app. If this doesn't eliminate the light On, recheck for leaks and connect with the app to verify the system status.
Tire Pressure/Supply Pressure Reads 255PSI	Low supply pressure/no supply pressure detected	255psi is a hexadecimal reading for supply pressure or tire pressure less than 1psi. Increase the supply pressure until the ECM can get an accurate pressure check completed of the tires. Supply pressure must be 10psi greater than the highest tire pressure.
Cannot Connect the ECM to the Mobile App	Bluetooth interference	Move to a location without bluetooth devices like watches, speakers, PC's, other phones, etc.
	Too many previously connected ECM devices in Bluetooth settings	Go into the device Bluetooth settings and unpair/forget all previously connected ECM's. Power down the ECM for 30 seconds and reconnect via the app.
Light comes back on after system startup and ECM is exhausting air every 30 seconds	Low supply pressure	Increase supply pressure until the ECM can get an accurate tire pressure reading. Supply pressure must be 10psi greater than the highest tire pressure.



From fifth wheel rebuild kits to suspension bushing repair kits, SAF-HOLLAND Original Parts are the same quality components used in the original component assembly.

SAF-HOLLAND Original Parts are tested and designed to provide maximum performance and durability. Will-fits, look-alikes or, worse yet, counterfeit parts will only limit the performance potential and could possibly void SAF-HOLLAND's warranty. Always be sure to spec SAF-HOLLAND Original Parts when servicing your SAF-HOLLAND product.

SAF-HOLLAND USA • 888.396.6501 • Fax 800.356.3929

www.safholland.us

SAF-HOLLAND CANADA • 519.537.3494 • Fax 800.565.7753

WESTERN CANADA • 604.574.7491 • Fax 604.574.0244

www.safholland.ca

SAF-HOLLAND MEXICO • 52.55.5362.8743 • Fax 52.55.5362.8743

www.safholland.com.mx

info@safholland.com